

A hand holding a red HPLC column labeled 'ProteCol C18 HQ 105 150mm' pointing at a molecular model. The molecular model consists of various colored spheres (blue, red, yellow, purple, grey) representing atoms, with some spheres connected by lines to form a complex structure. The background features a blue banner at the top and a large, light blue curved graphic at the bottom.

Turn Imagination into Results

ProteCol™ HPLC Columns

- Flexible hardware options
- High quality phases
- Perfect match for all your separation needs

 **SGE Analytical Science**
www.sge.com

AUSTRALIA & PACIFIC REGION

EUROPE

JAPAN

USA

ProteCol™ Column Range Introduction

Turn imagination into results with the ProteCol™ range of HPLC columns.

With Reverse Phase, Normal Phase and Specialty Phases, ProteCol ensures you have the right phase for your separation needs. With the option of combining inert PEEK coated hardware or traditional stainless steel with each quality phase, the ProteCol HPLC solution delivers the combination you require.



ProteCol Reverse Phase



- ProteCol C18 offers a flexible range of C18 bonded phases including pH stability and pore size options.
- ProteCol C8 columns have pore sizes to suit your analysis.
- ProteCol C4 columns have high durability and extended acidic and alkaline resistance.
- ProteCol Phenyl Hexyl columns offer unique selectivity.

ProteCol Normal Phase



- ProteCol Amino columns enable separation in both normal and reversed phase.
- ProteCol Cyano and Silica enable options for normal phase chromatography.

ProteCol Specialty Phase



- ProteCol HILIC range provides a polar stationary phase and highly organic mobile phase, allowing you to retain and separate polar analytes.
- ProteCol Chiral columns ensure the isolation and analysis of pure enantiomers.
- ProteCol PFP columns are useful in the separation of epimers.
- ProteCol SCX columns have a high loading capacity and pressure limit.

ProteCol Ultra Phase



- Range of phases for UHPLC use.

ProteCol HPLC columns are available in the following formats:

- Inert hardware: PEEK coated stainless steel or PEEKsil™ Capillary hardware
- Capillary HPLC
- Stainless steel
- UHPLC
- Semi preparative and preparative

Inert Hardware

- PEEK coated stainless steel
- Capillary HPLC
- Optimized analyte recovery
- Superior peak shape and reproducibility
- Less artifacts due to reduced carryover

The Importance of Inert HPLC Column Design

Non-specific interactions between the target analyte and the silica particles in the HPLC column are now well controlled with the availability of ultrapure silicas. Today, chromatographers expect silica sourced by manufacturers to be of the highest purity. What is often not considered is the role column hardware may play in non-specific interactions – the frit and internal column hardware can both influence the behavior of analytes with known metal chelating activity.

ProteCol offers two inert hardware options PEEK coated stainless steel, or PEEKsil™ capillary hardware.

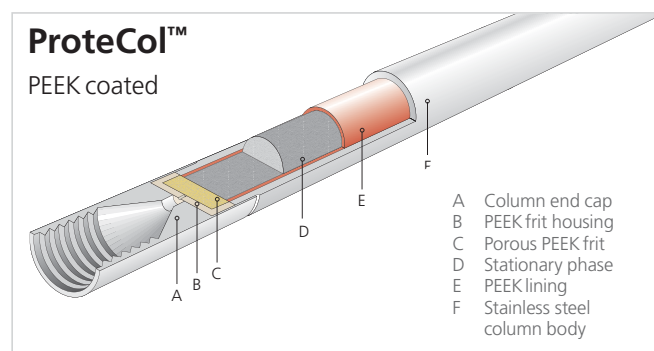
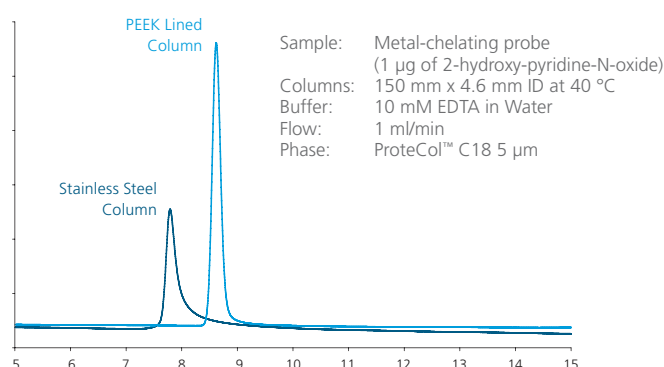

Most pharmaceutically active compounds and natural products have the potential to interact with metals. For this reason molecules like quinizarin, tetracycline or ciclopirox form tailing peaks in the presence of metal in the column or system.

Capillary HPLC



ProteCol Capillary HPLC Is Perfect For:

- Small samples - biotechnology, medical research, proteomics
- Exotic solvents - deuterated solvents for LC-NMR
- Low concentrations - highly potent pharmaceuticals, medical research
- Instrumentation - direct coupling into MS

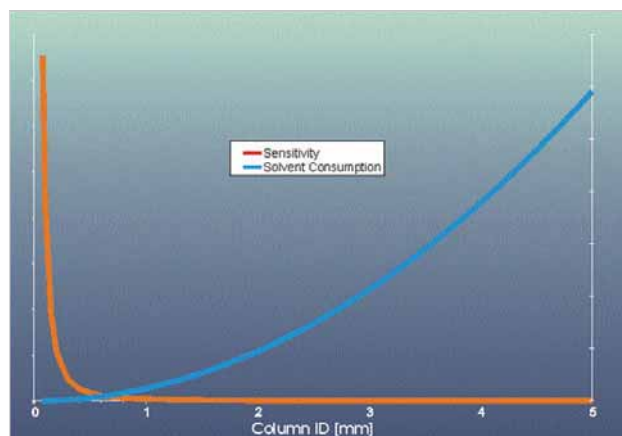
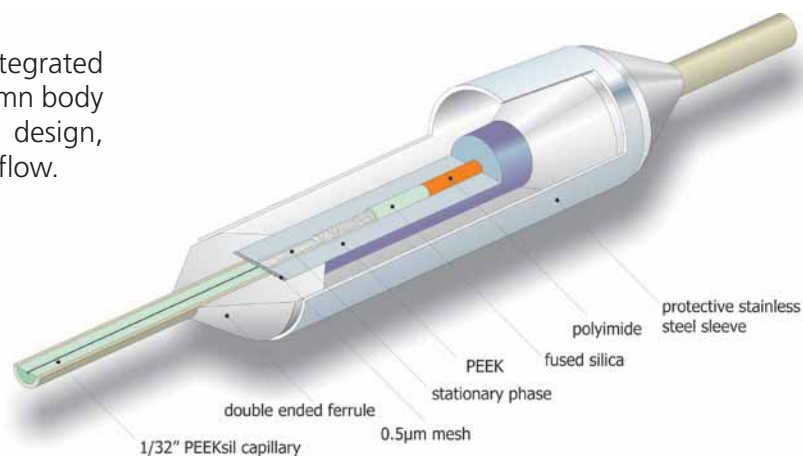

Figure demonstrating the relationship of analysis sensitivity with low volume use of solvents.

The ProteCol capillary HPLC design includes integrated connection tubing with PEEKsil™ for the column body and connection capillaries delivering robust design, zero volume connections and uninterrupted flow.



Stainless Steel Hardware

ProteCol HPLC with stainless steel hardware has both external body and end fittings manufactured from high quality 316 grade stainless steel.

UHPLC

Stainless steel hardware is designed specifically for UHPLC use, and standard with the ProteCol Ultra phases. These columns are for use at 19,000 psi.

Stability at pH 1:

Columns in the ProteCol range show no deterioration when exposed to pH 1.0 buffers.

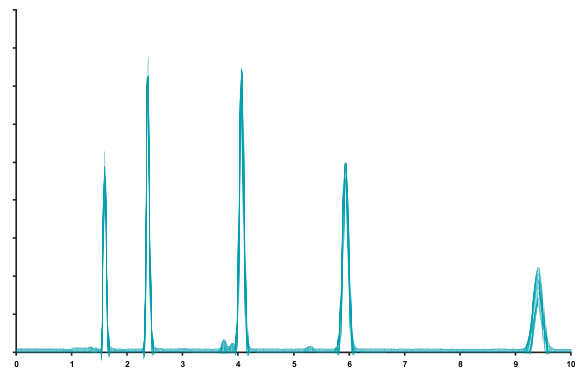

Overlay of 40 chromatograms run at pH 1.0 spanning 1200 column volumes.

Long-term Reproducibility

Columns in the ProteCol range show a remarkable reproducibility of thousands of injections (subject to sample purity and mobile phase conditions).

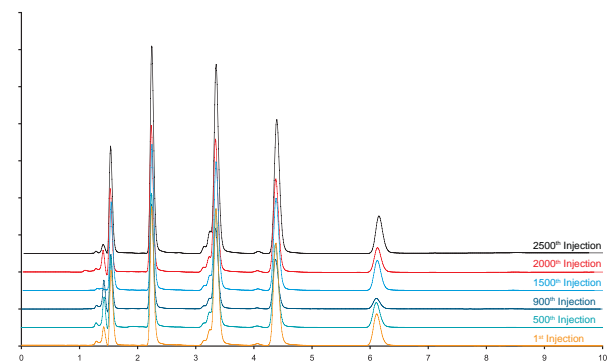

Chromatograms of a test mix over a period of 2500 injections.

Analysis of Larger Molecules

When analyzing samples containing large molecules (peptides, proteins, polymers with MW>3000) the size of the molecule and the size of the pore structure play an important role in the quality of the separation. As the analyte increases in size (relative to the pore size) the diffusion rate inside the pore becomes smaller and mass transfer in and out of the pore system becomes slow leading to band broadening. Obviously, when the analyte size is equal to or bigger than the pore size there can be no pore diffusion. A mathematical description of this relationship was published by Renkin (E.M. Renkin, J.Gen.Physio., 38 (1954) 225.) and helps to illustrate the phenomenon.

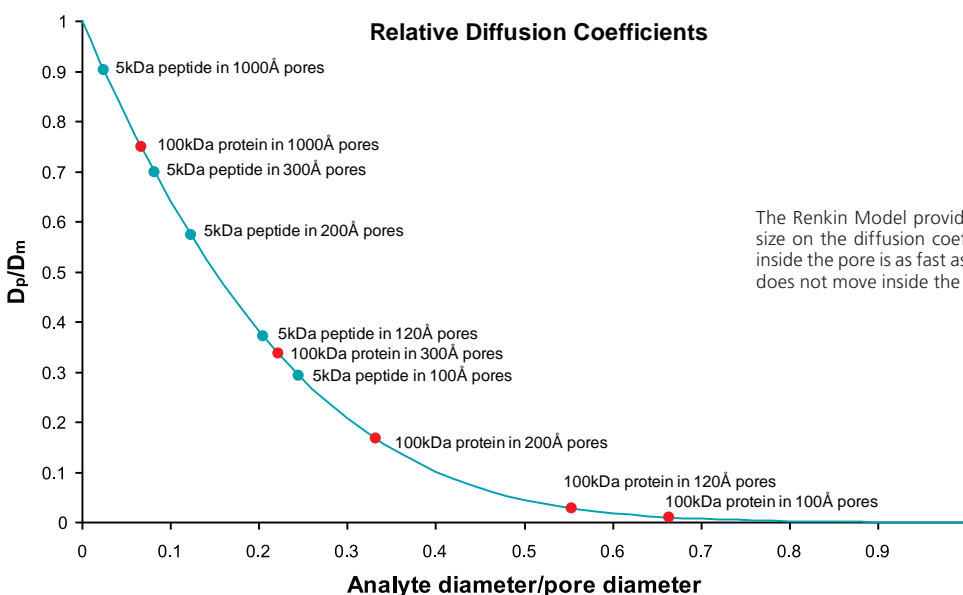

The Renkin Model provides an equation of the effect of pore and analyte size on the diffusion coefficient. A D_p/D_m value of 1 means the diffusion inside the pore is as fast as in the bulk liquid. $D_p/D_m = 0$ means the molecule does not move inside the pores.

An illustration of the relative diffusion rate of a 5kDa peptide and a 100kDa protein in a number of pore systems.

Reverse Phase ProteCol Range

- ProteCol C18 offers a flexible range of C18 bonded phases including pH stability and pore size options.
- ProteCol C8 columns have pore sizes to suit your analysis.
- ProteCol C4 columns have high durability and extended acidic and alkaline resistance.
- ProteCol Phenyl Hexyl columns offer unique selectivity.



Reverse Phase Column Selection Tree

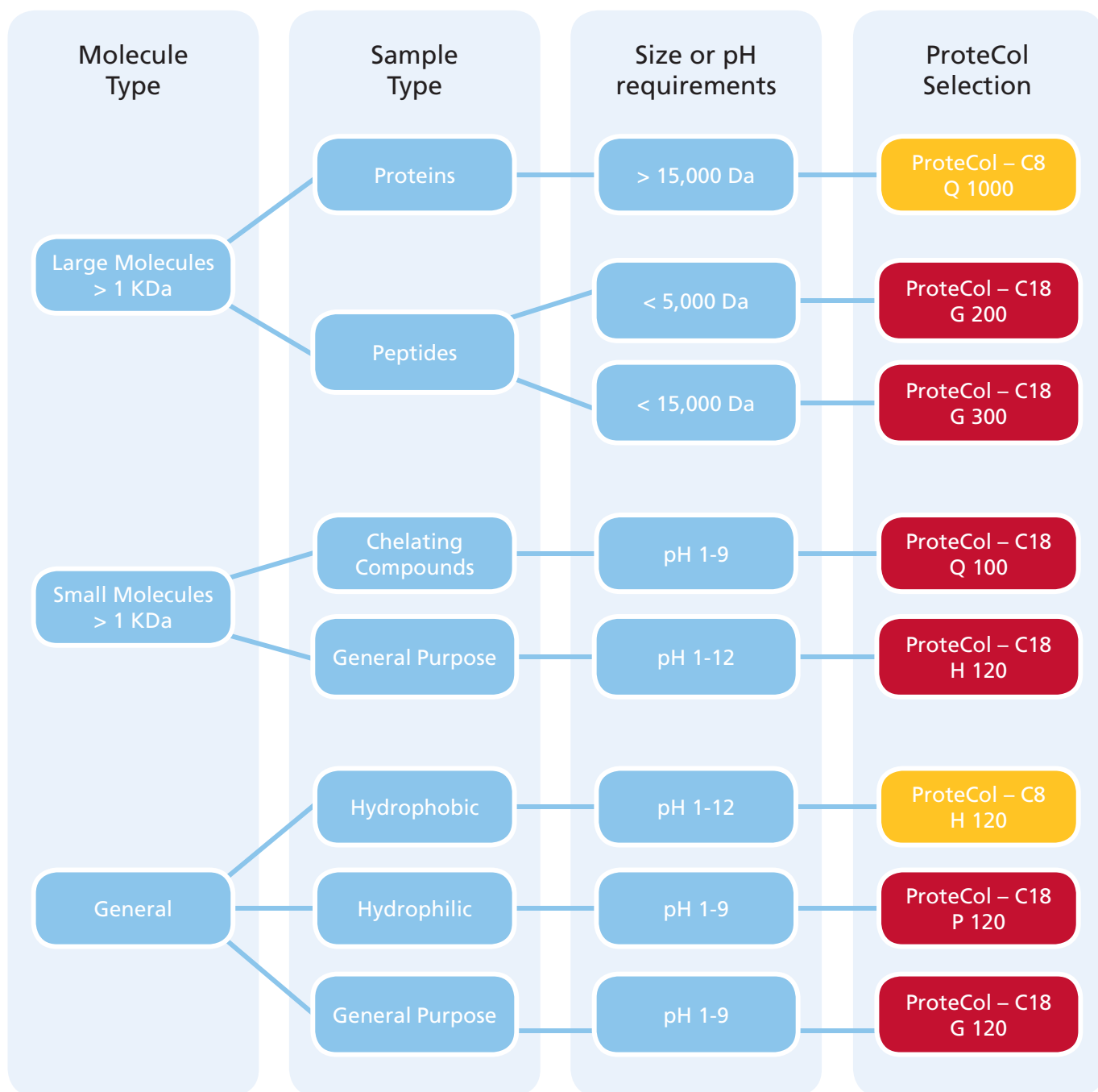

- Substantially reduced sample and column preparation time
- Improved peak shape giving you improved reproducibility and sensitivity
- Fewer artifacts due to reduced carry over
- Enables use of MS, ELSD and Corona CDA techniques

Four Chemistries

Phase	Pore Size (Å)	Particle Size (µm)	Pore Volume (ml)	Surface Area	Carbon Load %
C18 Q	100	3, 5	1.0 ± 0.1	400 ± 40	16.8
C18 G	120	2.5, 3, 5, 10	1.0 ± 0.1	300 ± 40	17.1
C18 G	200	3, 5	1.0 ± 0.1	200 ± 30	12.6
C18 G	300	3, 5	1.0 ± 0.1	100 ± 20	6.9
C18 H	120	5	1.0 ± 0.1	300 ± 40	20.9
C18 P	120	3, 5	1.0 ± 0.1	300 ± 40	14.5

C18 Q

- Ultra pure silica
- Fully end capped optimized C18 phases

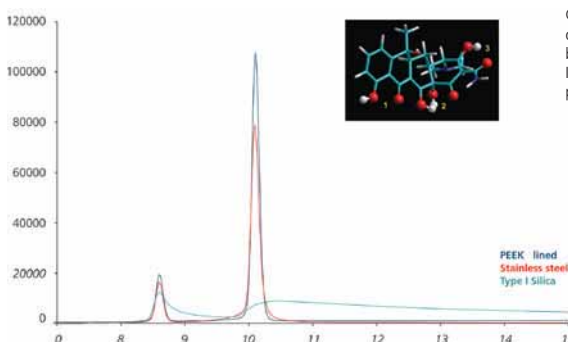

Chromatogram of tetracycline (antibiotic) and its major degradation product. Note the peak broadening on the base of the peak run through the stainless steel column. Inset: the tetracycline molecule depicting the three potential chelating groups.

C18 H

- Modified bonded phase making it easier to work from low to high pH using the same column
- Novel chemical bonding ensuring stability under extreme alkaline and acidic conditions
- pH stability 1 -11

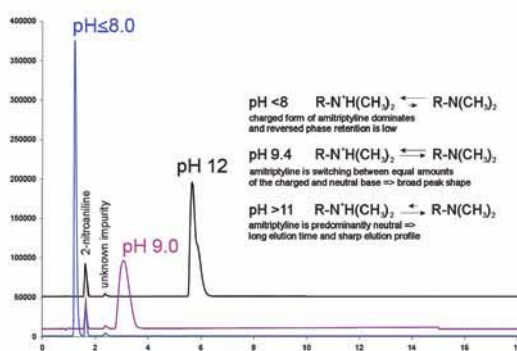

Column: 150 x 4.6 mm ID, C8 H125
 Sample: Content of Vitamin Supplement Capsules (Blackmores, Australia)
 Mobile Phase A: Water
 Mobile Phase B: Acetonitrile
 Gradient: 0 to 20 minutes 0 to 100% B
 20 to 80 minutes 100% B
 Flow Rate: 1 mL/min
 Temperature: 20 °C
 Detection: 210 nm

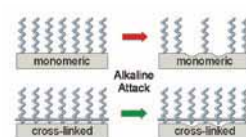

ProteCol™ H phase bonding

C18 G

- Stable in aqueous conditions
- Reduces non-specific analyte interactions
- Separates polar compounds
- pH stability 1 - 9

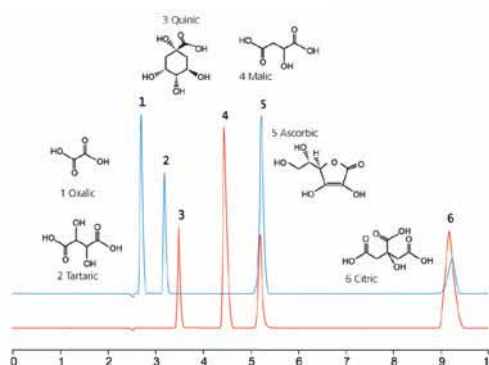

Column: 250 x 4.6 mm C18 G (5 µm)
 Mobile Phase: 20 mM KH_2PO_4 , pH 2.5 (H_3PO_4)
 1 mL/min
 Temperature: 30 °C
 Detection: 210 nm
 Samples: i) Test Mix (Organic Acids) — blue line
 ii) Cranberry Juice — red line

C18 P

- Polar embedded C18
- 100 % compatible with water
- pH stability 1 - 9

ProteCol C8



- 1000 Å pore size
- Intermediate polarity C8 phase
- Continuity of using HPLC for all separation needs simplifies your workflow
- Facilitates the use of MS
- Eliminate SDS-PAGE from your workflow

Phase	Pore Size (Å)	Particle Size (µm)	Pore Volume (ml)	Surface Area	Carbon Load %
C8	120	5	1.0 ± 0.1	300 ± 40	11.7
C8	1000	3	0.8 ± 0.1	25 ± 5	0.7

Column: ProteCol™ C8 Q1003, 300 µm ID x 100 mm
 Flow rate: 5 µL/min
 Mobile phase A: 0.1 % formic acid
 Mobile phase B: 95 % acetonitrile, 0.1 % formic acid
 Gradient: 0 min 5 % B, 30 min 55 % B, 33 min 70 % B, 38 min 70 % B, 40 min 5 % B

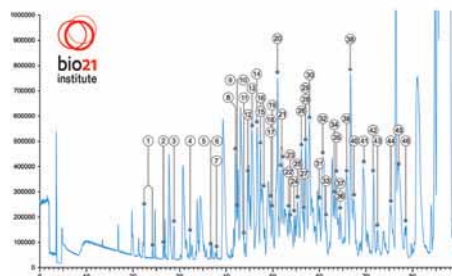

Base peak chromatogram of ribosomal proteins.

Why choose 1000 Å pore size?

1000 Å pore size silicas enable large irregular shaped proteins to bind to the bonded phase without restricting access to the pore - compared to 300 Å silicas whose pores are easily blocked by large proteins.

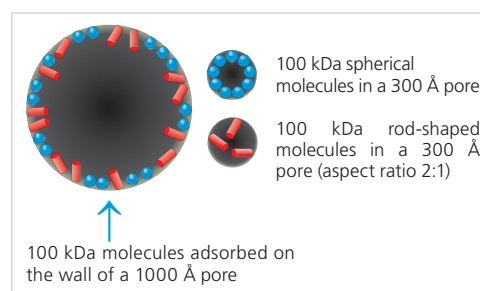

ProteCol C4



- 5 µm material
- Protein purification
- High durability
- Extended acidic and alkalic resistance
- Recommended for compounds too strongly retained on C18 and C8 phases

Phase	Pore Size (Å)	Particle Size (µm)	Particle Volume	Surface Area	% Carbon Load	pH
C4	300	5	0.9	100	3	1-11

Standard Proteins

Column: ProteCol™ C4
 150 x 4.6 mm
 Mobile Phase: A) CH₃CN/TFA (1000:1),
 B) H₂O/TFA (1000:1)
 A/B (20/80)
 Flow rate: 1.0 mL/min
 Detection: UV220 nm
 Temp: 35 °C

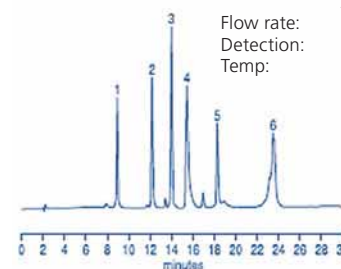

Sample:
 1. Ribonuclease
 2. Cytochrome
 3. Lysozyme
 4. BSA
 5. Myoglobin
 6. Ovalbumin

ProteCol Phenyl Hexyl



ProteCol Phenyl Hexyl uses a hexyl-linked phenyl phase where the hexyl alkyl chain delivers unique selectivity and increased hydrolytic stability when compared to propyl-linked chemistry. The example pictured highlights the separation of a mixture of Benzodiazapines, which is difficult to separate on a standard phenyl type column.

Phase	Pore Size (Å)	Particle Size (µm)	Surface Area	% Carbon Load	pH
Phenyl Hexyl	120	3, 5	350	10.0	1-10

Column: ProteCol™ Phenyl-Hexyl
 Mobile Phase: Acetonitrile/Water (80:20)
 Flow rate: 1.0 mL/min
 Detection: UV235 nm
 Sample: 1. Lormetazepam
 2. Diazepam
 3. Oxazepam

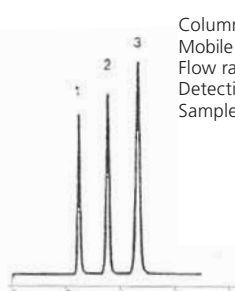

Normal Phase ProteCol™ Range

- ProteCol Amino column allows basic compound separation in normal phase and carbohydrate analysis.
- ProteCol Cyano columns provide chromatographic retention both in normal and reversed phase separation due to its moderate polarity.
- ProteCol Silica columns have high durability and extended acidic and alkaline resistance.



ProteCol Amino

Specifications

- Bonded with amino-propyl silane

Applications

- Basic compound separation under normal phase conditions
- Saccharide separation using acetonitrile/water

Phase	Pore Size (Å)	Particle Size (µm)	Surface Area	% Carbon Load
Amino	120	3, 5	350	4.0

Malto-oligosaccharides

Column: ProteCol™ Amino 125
150 x 6 mm

Eluent: CH₃CN/H₂O-50/50

Flow rate: 1.0 mL/min

Detection: RID

Temp.: 40 °C

Sample: 1. Glucose
2. Maltose
3. Maltotriose
4. Maltotetraose
5. Maltopentaose

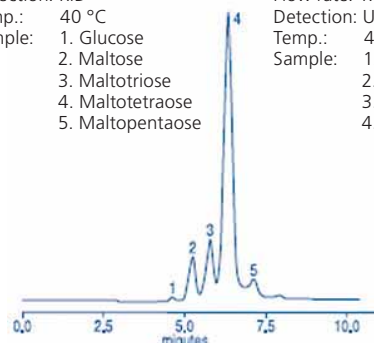

Tocopherol isomers

Column: ProteCol™ Amino 125
150 x 6 mm

Eluent: Hexane/Ethyl acetate
(70:30)

Flow rate: 1.0 mL/min

Detection: UV 295 nm

Temp.: 40 °C

Sample: 1. α Tocopherol
2. β Tocopherol
3. γ Tocopherol
4. δ Tocopherol

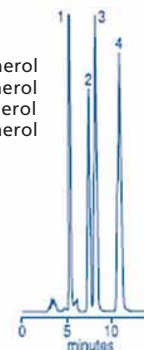

ProteCol Cyano

Common applications are for the separation of flavonoids, extraction of polar compounds from non-polar samples as well as the analysis of samples containing analytes with a wide range of hydrophobicity.

Phase	Pore Size (Å)	Particle Size (µm)	Surface Area	% Carbon Load
Cyano	120	5	300	5



ProteCol Silica

High surface area and mechanical strength.

Phase	Pore Size (Å)	Particle Size (µm)	Surface Area	% Carbon Load
Silica	120	3, 5, 10	300	0

Specialty Phase ProteCol™ Range

- ProteCol Chiral columns ensure the isolation and analysis of pure enantiomers.
- ProteCol HILIC range provides a polar stationary phase enabling the retention and separation of polar analytes using organic mobile phases.
- ProteCol SCX column has a high loading capacity and pressure limit.
- ProteCol PFP column is useful in the separation of epimers.



ProteCol Chiral



- ProteCol Chiral CHM is a modified cellulose coated on high purity, high performance spherical silica particles. The chemical modification includes the chemical bonding of 3-chloro-4 methylphenylcarbamate to cellulose. The use of cellulose modified with chlorinated phenyl groups provides for the separation for many previously unresolved or poorly resolved chiral mixtures.
- ProteCol Chiral CHC are polysaccharide coated chiral columns, manufactured using a unique production process of coating the proven chiral selector-tris-(3,5-dimethylphenyl) carbamoyl cellulose on high purity silica gel.
- ProteCol Chiral CHA polysaccharide coated chiral columns, are created using a unique production process of coating the proven chiral selector-tris-(3,5-dimethylphenyl) carbamoyl amylose on high purity silica gel.
- ProteCol Chiral CH4 uses a modified cellulose coated on high purity, high performance spherical silica particles and consists of the chemical bonding of 4-chloro-3 methylphenylcarbamate to cellulose. The use of cellulose modified with chlorinated phenyl groups provides for the separation for many previously unresolved or poorly resolved chiral mixtures.

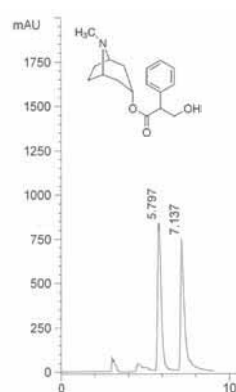

ProteCol™ CHC
 Column Size: 250 X 4.6 mm
 Particle Size: 5 micron
 Sample Name: Atropine
 Mobile Phase: Hexane/Ethanol 90/10
 Flow Rate: 1.0 mL/min
 Injection Vol: 10.0 µL
 Pressure: 38.6 bar

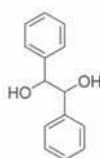
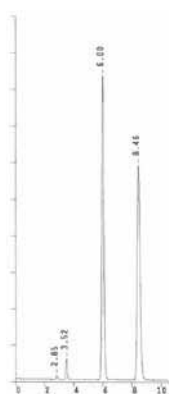

ProteCol CHA
 Column Size: 250 X 4.6mm
 Particle Size: 5 micron
 Sample Name: Hydrobenzoin
 Mobile Phase: 15% Ethanol in Hexane
 Flow Rate: 1.0 mL/min
 Injection Vol: 5.0 µL
 Pressure: 31 bar

Phase	Sub Phase	Chemical Structure	Particle Size (µm)
Chiral	CHC	3, 5-dimethylphenylcarbamate cellulose	5, 10
Chiral	CHA	3, 5-dimethylphenylcarbamate amylose	5, 10
Chiral	CHM	3-chloro-4-methylphenylcarbamate cellulose	5, 10
Chiral	CH5	5-chloro-2-methylphenylcarbamate amylose	5, 10
Chiral	CH4	4-chloro-3-methylphenylcarbamate cellulose	5, 10

Semi-preparative and preparative formats are available.

HILIC chromatography uses mobile phases containing between 5 - 20 % water for the retention of polar compounds. The ProteCol range of HILIC columns delivers you separation specific for your polar analyte analysis.

ProteCol HILIC-RP

ProteCol HILIC-RP columns deliver a combination of HILIC and reversed phase chromatography – perfect for samples containing polar and hydrophobic analytes. The composition of both the polyhydroxylated polymer and ODS groups bound to silica provides hydroxyl levels that are well above conventional hydroxyl and diol type stationary phases.

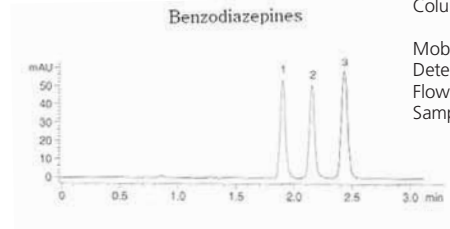

Column: ProteCol™ HILIC-RP
250 x 4.6 mm 5µm
Mobile Phase: Methanol/Water (90:10)
Detection: uv @ 235 nm
Flow: 1.0 mL/min
Sample: 1. Lorazepam
2. Diazepam
3. Oxazepam

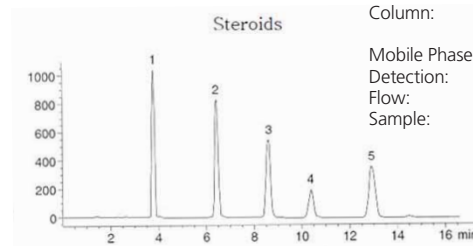

Column: ProteCol™ HILIC-RP
250 x 4.6 mm 5µm
Mobile Phase: Methanol/Water (70:30)
Detection: uv @ 254 nm
Flow: 1.0 mL/min
Sample: 1. Hydrocortisone
2. Corticosterone
3. 11 α -Hydroxyprogesterone
4. Cortisone Acetate
5. 11 - Ketoprogesterone

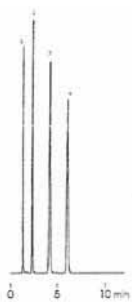

Column: ProteCol™ HILIC-FL
150 x 4.6 mm 5µm
Mobile Phase: 10 mM ammonium acetate in water:
Acetonitrile 5:95
Flow: 1 mL/min
Detection: uv @ 21.0 nm
Sample: 1. MDA
2. Amphetamine
3. MDMA
4. Methamphetamine

ProteCol HILIC-FL

ProteCol HILIC-FL is designed for retention and separation of polar and non-polar compounds that are not retained or separated on conventional reversed phase columns. It consists of a fluorinated based stationary phase bound to silica. This composition provides for excellent retention and peak shape for polar halogenated, polar amines and polar aromatic compounds.

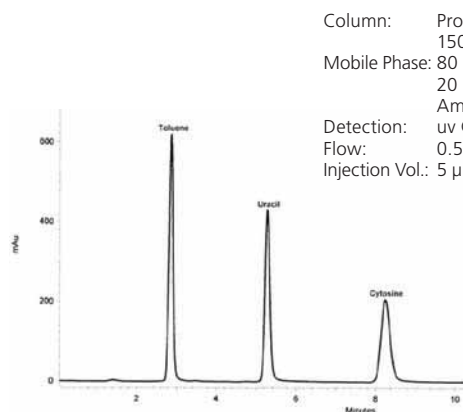

Column: ProteCol™ HILIC-HC
150 x 4.6 mm 5µm
Mobile Phase: 80 % Acetonitrile
20 % 5 mM Ammonium acetate
Detection: uv @ 254 nm
Flow: 0.5 mL/min
Injection Vol.: 5 µL

ProteCol HILIC-HC

ProteCol HILIC-HC (high capacity) is composed of a polyhydroxylated polymer coated and bound to silica, providing hydroxyl levels that are well above conventional hydroxyl and diol type stationary phases.

The chromatogram highlights the unique capability for ProteCol HILIC-HC, where toluene is less retained than uracil. Uracil has been traditionally used as an unretained marker for the determination of void volume, however with ProteCol HILIC-HC and an 80% acetonitrile mobile phase, uracil can be retained.

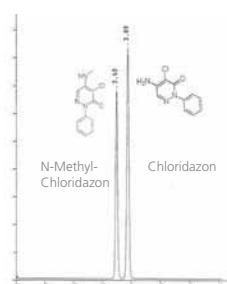

Column: ProteCol™ HILIC-PI
150 x 4.6 mm 5µm
Mobile Phase: Acetonitrile/Water (90:10)
Detection: uv @ 254 nm
Flow: 1.0 mL/min

ProteCol HILIC-PI

ProteCol HILIC-PI consists of an aromatic amine based stationary phase bound to silica. This composition provides for excellent retention and peak shape for polar amine compounds.

ProteCol SCX

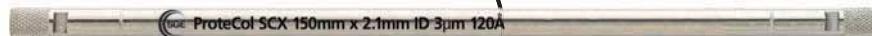

ProteCol SCX is a silica based strong cation exchanger suitable for the analysis of small organic bases. Based on a bonded aromatic sulfonic acid group and available in 5 and 3 μm particle size, ProteCol SCX will deliver superb performance:

- High loading capacity and pressure limit
- Robust bonding technology
- High density bonding
- Bonding aromatic sulfonic acid groups

Phase	Pore Size (Å)	Particle Size (μm)	Surface Area	pH
SCX	120	3, 5	350	1-10

ProteCol PFP



PFP is a truly unique stationary phase with properties significantly different from ODS phases. This unique character results from bonded pentafluorophenyl groups imparting a pi-pi electron interaction, producing an enhanced retention for many compounds, particularly those that contain polarizable electrons. Many classes of compounds and naturally occurring chemicals also contain polarizable electrons and can be separated using PFP. PFP has been extremely useful in the separation of epimers. Epimers also exist in many natural mixtures such as pharmaceutically active natural paclitaxel.

Phase	Pore Size (Å)	Particle Size (μm)	Surface Area	% Carbon Load	pH
PFP	120	3, 5	350	10.0	1-10

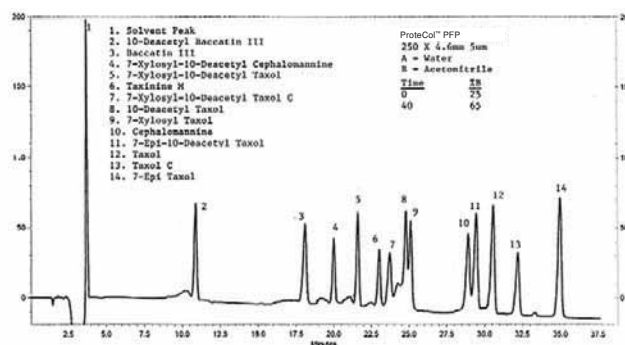

Column Application Recommendations and USP Guide

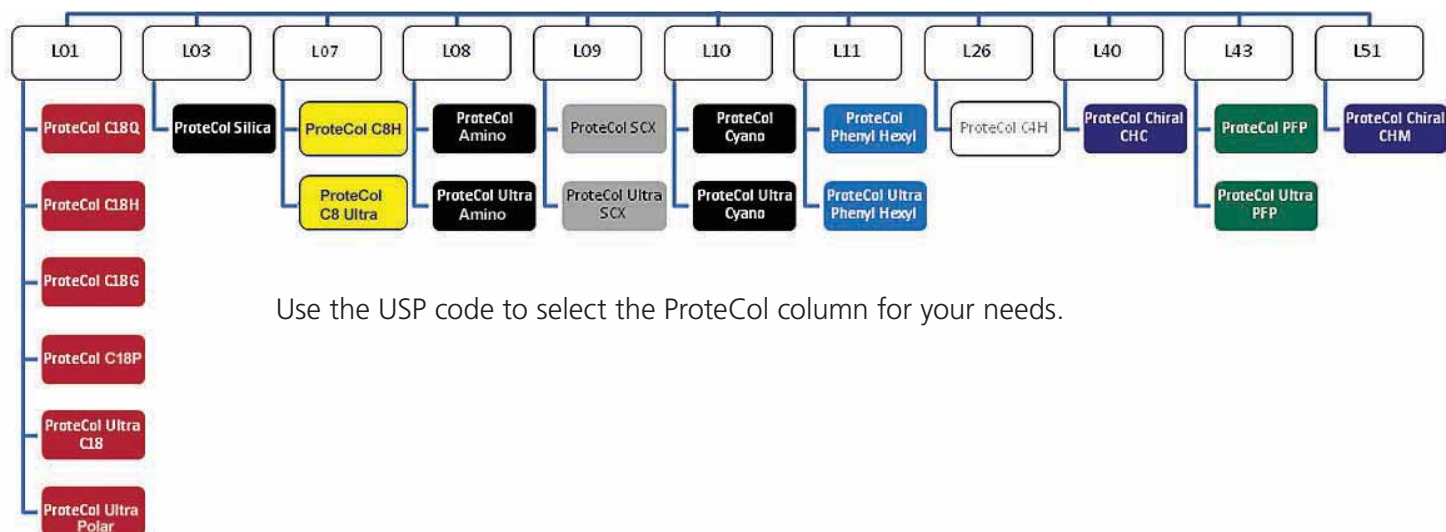

	Small Analyte	Large Analyte	Polar Analyte	Very Hydrophobic Analyte	Low Nonspecific Interaction	Fast Analysis	Extreme pH Conditions	Chiral Analysis	Halogenated Samples	Basic Samples	Range of Hydrophobicities in Analyte	HILIC Applications	Aromatic Samples
ProteCol C18 Q	Y	N	O	O	Y	N	N	N	Y	Y	Y	N	Y
ProteCol C18 H	Y	N	O	O	O	N	Y	N	Y	O	Y	N	Y
ProteCol C18 G	Y	N	O	O	O	N	N	N	Y	O	Y	N	Y
ProteCol C18 P	Y	N	Y	O	N/A	N	N	N	Y	O	Y	N	Y
ProteCol C8 Q	Y	N	N	Y	O	N	N	N	Y	O	Y	N	Y
ProteCol C8 H	Y	N / Y ⁴	N	Y	O	N	N	N	Y	O	Y	N	Y
ProteCol C4 H	Y	N / Y ⁴	N	Y	O	N	N	N	Y	O	Y	N	Y
ProteCol Phenyl Hexyl	Y	N	O	O	O	N	N	N	Y	O	Y	N	Y ²
ProteCol Silica	Y	N	Y	N	N/A	N	N	N	Y	Y	Y	Y	Y
ProteCol Amino	Y	N	Y	N	N/A	N	N	N	Y	Y	Y	Y	Y
ProteCol Cyano	Y	N	Y	Y ³	N/A	N	N	N	Y	O	Y	O	O
ProteCol HILIC RP	Y	N	Y	N	N/A	N	N	N	Y	Y	Y	Y	Y
ProteCol HILIC PI	Y	N	Y	N	N/A	N	N	N	Y	Y	Y	Y	Y
ProteCol HILIC FL	Y	N	Y	N	N/A	N	N	N	Y ¹	O	Y	Y	Y
ProteCol HILIC HC	Y	N	Y	N	N/A	N	N	N	Y	Y	Y	Y	Y
ProteCol Chiral CHC	Y	N	N/A	N/A	N/A	N	N	Y	N/A	N/A	N/A	N/A	N/A
ProteCol Chiral CHM	Y	N	N/A	N/A	N/A	N	N	Y	N/A	N/A	N/A	N/A	N/A
ProteCol Chiral CHA	Y	N	N/A	N/A	N/A	N	N	Y	N/A	N/A	N/A	N/A	N/A
ProteCol Chiral CH5	Y	N	N/A	N/A	N/A	N	N	Y	N/A	N/A	N/A	N/A	N/A
ProteCol Chiral CH4	Y	N	N/A	N/A	N/A	N	N	Y	N/A	N/A	N/A	N/A	N/A
ProteCol SCX	Y	N	Y	N	N/A	N	N	N	Y	Y	N	O	N
ProteCol PFP	Y	N	O	O	O	N	N	N	Y ¹	O	Y	N	Y
ProteCol Ultra C18	Y	N	O	O	N	Y	N	N	Y	O	Y	N	Y
ProteCol Ultra C8	Y	N	N	Y	N	Y	N	N	Y	O	Y	N	Y
ProteCol Ultra Amino	Y	N	Y	N	N/A	Y	N	N	Y	O	Y	Y	Y
ProteCol Ultra Cyano	Y	N	Y	Y ³	N/A	Y	N	N	Y	O	Y	Y	O
ProteCol Ultra HILIC FL	Y	N	Y	N	N/A	Y	N	N	Y	O	Y	N	O
ProteCol Ultra HILIC PI	Y	N	Y	N	N/A	Y	N	N	Y	Y	Y	N	Y
ProteCol Ultra PFP	Y	N	O	O	N	Y	N	N	Y ¹	O	Y	N	Y
ProteCol Ultra Phenyl	Y	N	N	Y	N	Y	N	N	Y	O	Y	N	Y ²
ProteCol Ultra Phenyl Hexyl	Y	N	O	O	N	Y	N	N	Y	O	Y	N	Y ²
ProteCol Ultra Polar	Y	N	Y	O	N	Y	N	N	Y	O	Y	N	Y
ProteCol Ultra SCX	Y	N	Y	N	N/A	Y	N	N	Y	Y	N	O	N

¹⁾ Pentafluorophenyl has a special selectivity for halogenated substances and should be used when separation on conventional RP phases is difficult.

²⁾ Phenyl and Hexaphenyl have a special selectivity for aromatic substances and should be used when separation on conventional RP phases is difficult.

³⁾ In reversed phase mode.

⁴⁾ When particles with 200Å, 300Å or 1000Å are chosen.

Y = Recommended

N = Not Recommended

O = Optional

How to Order - Building your HPLC Column Part Number

The SGE ProteCol™ range of HPLC columns offers you many combinations where you can select the phase, particle size, column length and ID, as well as column hardware.

To make ordering easier, please use the following guide when building your column for your application:

- The part number starts with **Phase Code**, **Particle Size**, **Length Code**, **ID Code**, **Hardware Code** and whether it is a guard column.
- If you want a guard column to complement an analytical column, add "G" as a suffix.



Example:



PARTICLE SIZE		LENGTH CODE		ID CODE		HARDWARE CODE	
Particle Size	Particle Size Code	Length	Length Code	ID	ID Code	Hardware	Hardware Code
1.8	18	10	G	0.15	15	Stainless Steel	S
2.5	25	10	T	0.3	30	UHPLC	U
3	03	50	L	1	01	PEEKsil™	K
5	05	100	M	2.1	02	PEEK Coated	P
10	10	150	N	3	03		
		250	R	4.6	46		
				10	10		



Refer to the table on the next page

Build a column easily by downloading our HPLC Part Number Generator at www.sge.com/lc

PHASE						
Phase	Length	ID	Pore Size (Å)	Phase Code	Particle Size (µm)	Hardware Code
ProteCol™ C18 Q	LMNR	15, 30, 01, 02, 03, 46	100	2C183	3, 5	SKP
ProteCol™ C18 H	LMNR	15, 30, 01, 02, 03, 46	120	2C182	3, 5	SKP
ProteCol™ C18 G	LMNR	15, 30, 01, 02, 03, 46	120	2C185	2.5, 3, 5, 10	SKP
ProteCol™ C18 P	LMNR	15, 30, 01, 02, 03, 46	120	2POL	3, 5	SKP
ProteCol™ C8 H	LMNR	15, 30, 01, 02, 03, 46	120	2C83	3, 5	SKP
ProteCol™ C18 G	LMNR	15, 30, 01, 02, 03, 46	200	2C181	3	SKP
ProteCol™ C18 G	LMNR	15, 30, 01, 02, 03, 46	300	2C184	3, 5	SKP
ProteCol™ C8 H	LMNR	15, 30, 01, 02, 03, 46	1000	2C82	3	SKP
ProteCol™ C4 H	LMNR	15, 30, 01, 02, 03, 46	300	2C42	5	SKP
ProteCol™ Phenyl Hexyl	LMNR	02, 03, 46	120	2NH4	3, 5	SP
ProteCol™ Silica	LMNR	02, 03, 46	120	2SIL	3, 5, 10	SP
ProteCol™ Amino	LMNR	02, 03, 46	120	2AM	5	SP
ProteCol™ Cyano	LMNR	02, 03, 46	120	2CN	5	SP
ProteCol™ HILIC RP	LMNR	02, 03, 46	120	2HL6	3, 5	SP
ProteCol™ HILIC PI	LMNR	02, 03, 46	120	2HL7	5	SP
ProteCol™ HILIC FL	LMNR	02, 03, 46	120	2HL8	5	SP
ProteCol™ HILIC HC	LMNR	02, 03, 46	120	2HL9	3, 5	SP
ProteCol™ Chiral CHC	R	46	-	2CHC	5, 10	SP
ProteCol™ Chiral CHM	R	46	-	2CHM	5, 10	SP
ProteCol™ Chiral CHA	R	46	-	2CHA	5, 10	SP
ProteCol™ Chiral CH5	R	46	-	2CH5	5, 10	SP
ProteCol™ Chiral CH4	R	46	-	2CH4	5, 10	SP
ProteCol™ SCX	LMNR	02, 03, 46	120	2SCX	3, 5	SP
ProteCol™ PFP	LMNR	02, 03, 46	120	2PFP	3, 5, 10	SP
ProteCol™ Ultra C18*	LMN	02	120	2UC18	1.8	U
ProteCol™ Ultra C8*	LMN	02	120	2UC8	1.8	U
ProteCol™ Ultra Amino*	LMN	02	120	2UAM	1.8	U
ProteCol™ Ultra Cyano*	LMN	02	120	2UCN	1.8	U
ProteCol™ Ultra HILIC FL*	LMN	02	120	2UHL8	1.8	U
ProteCol™ Ultra HILIC PI*	LMN	02	120	2UHL7	1.8	U
ProteCol™ Ultra PFP*	LMN	02	120	2UPFP	1.8	U
ProteCol™ Ultra Phenyl*	LMN	02	120	2UPH	1.8	U
ProteCol™ Ultra Phenyl Hexyl*	LMN	02	120	2UNH4	1.8	U
ProteCol™ Ultra Polar*	LMN	02	120	2UPOL	1.8	U
ProteCol™ Ultra SCX*	LMN	02	120	2USCX	1.8	U

*Note no guard columns available.

	Guard Columns (pack of three)					Trap Columns (single pack)	
ProteCol™ C18 P-120Å	4.6 mm ID	3.0 mm ID	2.1 mm ID	300 µm ID	150 µm ID	300 µm ID	150 µm ID
ProteCol™ C18 Q-100Å	4.0 mm ID	4.0 mm ID	2.1 mm ID	300 µm ID	150 µm ID	300 µm ID	150 µm ID
ProteCol™ C18 Q-200Å	4.0 mm ID	4.0 mm ID	2.1 mm ID	300 µm ID	150 µm ID	300 µm ID	150 µm ID
ProteCol™ C18 Q-300Å	4.0 mm ID	4.0 mm ID	2.1 mm ID	300 µm ID	150 µm ID	300 µm ID	150 µm ID
ProteCol™ C18 H-120Å	4.0 mm ID	4.0 mm ID	2.1 mm ID	300 µm ID	150 µm ID	300 µm ID	150 µm ID
ProteCol™ C18 G-120Å	4.0 mm ID	4.0 mm ID	2.1 mm ID	300 µm ID	150 µm ID	300 µm ID	150 µm ID
ProteCol™ C8 H-120Å	4.0 mm ID	4.0 mm ID	2.1 mm ID	300 µm ID	150 µm ID	300 µm ID	150 µm ID
ProteCol™ C8 H-1000Å	4.0 mm ID	4.0 mm ID	2.1 mm ID	300 µm ID	150 µm ID	300 µm ID	150 µm ID
ProteCol™ C4 H-300Å	4.0 mm ID	4.0 mm ID	2.1 mm ID	300 µm ID	150 µm ID	300 µm ID	150 µm ID
ProteCol™ Silica-120Å	4.0 mm ID	4.0 mm ID	2.1 mm ID	N/A	N/A	N/A	N/A
ProteCol™ Amino-120Å	4.0 mm ID	4.0 mm ID	2.1 mm ID	N/A	N/A	N/A	N/A
ProteCol™ Cyano-120Å	4.0 mm ID	4.0 mm ID	2.1 mm ID	N/A	N/A	N/A	N/A

Inner diameter of the guard columns provided. Particle size of the stationary phase is corresponding with the particle size of the main column (please specify when ordering).

HPLC Method Development

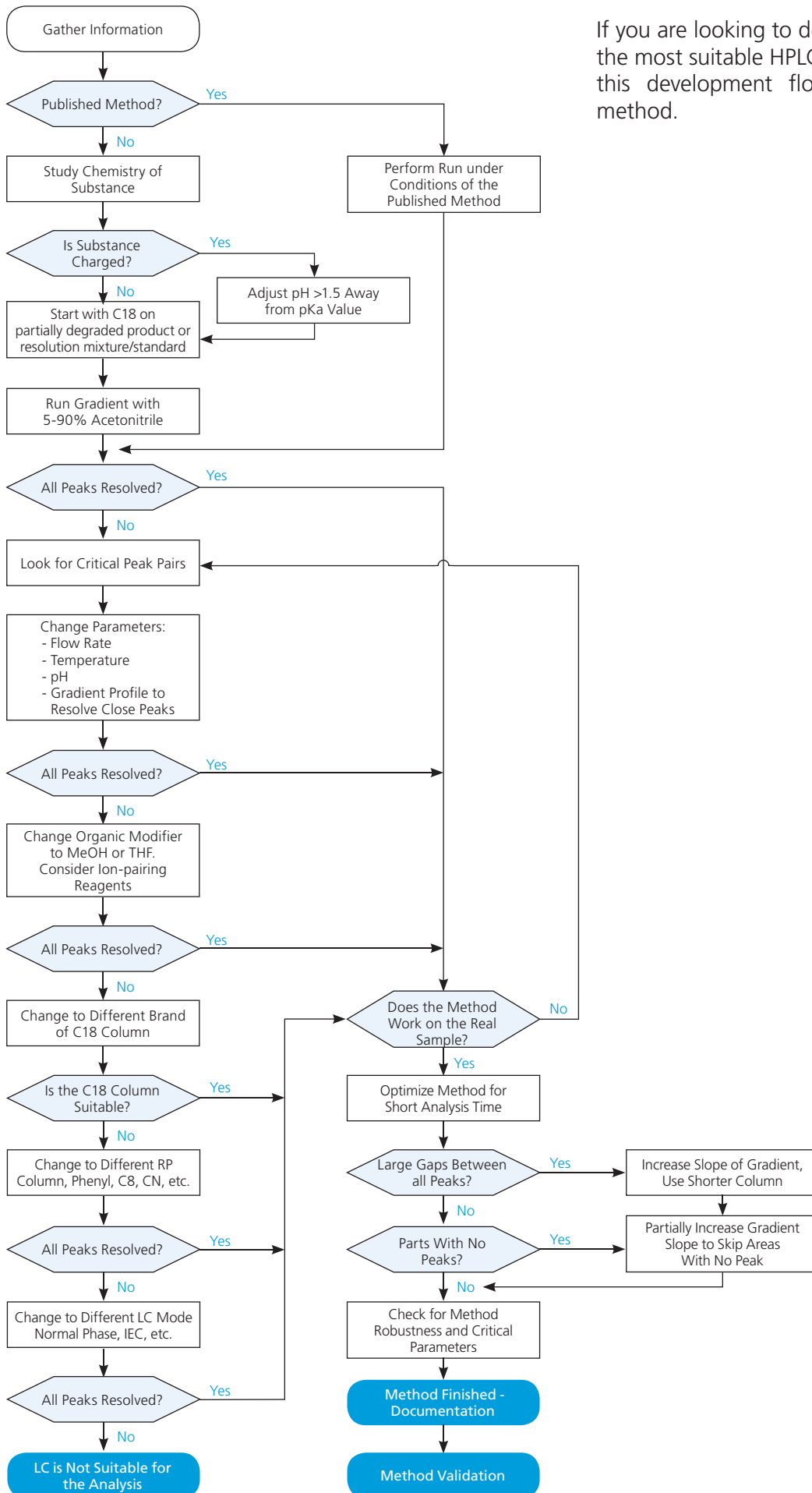

If you are looking to develop a method and determine the most suitable HPLC column for the analysis, follow this development flowchart to establish the best method.

Problem	Reason	Resolution
System Related		
Low/unsteady system pressure	Leak.	Check all connections and tighten connections, replace seals.
	Air in pump head.	Degas mobile phase and purge system.
High system pressure	Dirt in check valve (check whether valve cannot close).	Firstly try purging system at high flow rate to dislodge contamination. Secondly, disassemble check valve and sonicate.
	Blockage (contamination).	Open connections sequentially from the detector back to the pump to locate blockage. Flush capillaries, replace in-line filters or guard columns, clean injector valve, reverse column flow (without detector in-line!) depending on where the blockage was located.
	Blockage (precipitated buffer salts) can happen when the system or user suddenly changes mobile phase composition from high organic to aqueous buffer or vice versa.	Disconnect column and flush with pure water at low flow rate to dissolve buffer salts again.
	High viscosity mobile phase.	Increase temperature, change mobile phase, or decrease flow rate.
	Small stationary phase particles.	Increase temperature, reduce flow rate, use shorter column.
Noisy, fluctuating, drifting baseline	Crushed particles (sudden pressure spikes can cause porous silica to fracture and generate "fines").	Replace the column
	System contamination.	Disconnect column and rinse system with a combination of acid (10% nitric acid or 15% phosphoric acid for a short period of time followed by water and a organic wash of 75% acetonitrile/25% IPA over night) Do NOT run the acid through the column!
	Age of the UV lamp.	Replace the UV lamp.
	Temperature fluctuations.	Use column oven.
Regular pulsing of the baseline	Higher UV absorption of either mobile phase A or B causes drift in gradient elution.	Use HPLC grade solvents, check UV cut-off values for mobile phase components, change to higher wavelength.
	Air in pump head (also causes pulsing of the back pressure).	Degas mobile phase and purge system.
	Dirt in check valve (also causes pulsing of the back pressure).	First try purging system at high flow rate to dislodge contamination. Second disassemble check valve and sonicate.
The Chromatogram	Bubble trapped in the flow cell – the detector response changes dramatically when the detector outlet is temporarily blocked with a finger.	Degas mobile phase and purge system.
	Wrong pH (some peaks are tailing while others are symmetrical).	The pH of the mobile phase should be 1.5 units or more above or below the pKa value of the analyte to have all molecules either in the charged or in the neutral state.
Tailing peaks	Void volumes (all peaks are tailing).	Check connections, replace guard column, replace column.
	Non-specific interactions (some/all sample components can interact with active sites in the flowpath - silanol groups, metal surfaces of tubes and frits).	Replace column with an inert column, replace metal tubing with PEEKsil™ tubing. Add additives (e.g. EDTA) into mobile phase, lower pH to <2.5 in order to protonate silanol groups.
	Channeling.	Channeling indicates a serious problem with the column and the column needs replacing. For the interim you can try to reverse the column flow direction.
Fronting/tailing peaks	"Viscous fingering" – happens when there is a large difference between the viscosity of the sample and the viscosity of the mobile phase.	Try to match the viscosity of the sample with the mobile phase. Ideally, always use mobile phase as the sample diluent.
	Stationary phase degradation.	Loss of ligands when the column is exposed to extreme pH or when the column is very old can lead to peak fronting. Replace the column.
	Column over loading.	Reduce the amount of sample injected or use a column with a larger ID.

More Than Just Packaging

HPLC Packaging

SGE has developed improved packaging, enabling you to receive your column with confidence and store it securely. By designing packaging that combines shipping and storage solutions, chaotic drawers and expensive HPLC specific storage are eliminated.



Opens flat to store columns and accessories in your drawer.

Test Report

Guard Column

Label to identify column

Store up to three full sized analytical columns.

Complementary HPLC Products and Supplies

MEPS™

MEPS™ (Micro Extraction by Packed Sorbent) is a micro SPE solution that incorporates the stationary phase in a micro-cartridge integrated in a high quality SGE analytical syringe (Barrel Insert and Needle - BIN configuration).

MEPS is the miniaturization of conventional SPE packed bed devices from mL to μ L bed volumes.

eVol® MEPS stationary phases available: C2, C8, C18, APS, DVB, SDVB.

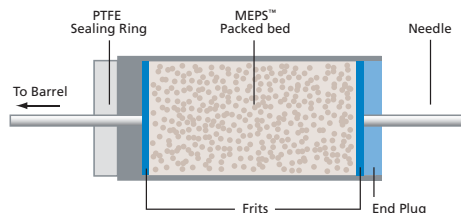

Schematic of the MEPS™ stationary phase within the syringe needle – SGE's patented 'Barrel Insert and Needle' (BIN) configuration.



ProteCol™ Guard Columns and Filters

Analytical Protection

ProteCol Filter

The ProteCol filter is designed to filter the sample prior to the pre-column. Peak broadening has been eliminated due to low dead volume, inert design.

ProteCol Guard Column

We recommend the use of ProteCol Guard columns to protect the analytical column, and ensure it performs consistently. The guard column is designed to fit into the back of a PEEK fingertight fitting (provided with the guard column). No further unions are required.



Capillary Protection

- Zero dead volume filter design.
- Zero pressure drop across filter.
- Zero compromise on performance.



The ProteCol In-Line Filter is a simple and effective way to protect your capillary columns from particulates. It protects your system from blockages and increased back pressures without introducing peak tailing or loss of resolution. The filtering element is a 2 micron porosity screen, located between the square-cut and polished ends of two lengths of PEEKsil™ tubing ('tails').

Accessories

HPLC Tubing

PEEKsil™ may be used as a direct replacement for conventional stainless steel as well as a replacement for PEEK tubing used in LC systems. The PEEK polymer exterior coating and the fused silica combination makes PEEKsil very robust, making it ideal for capillary HPLC and LC-MS applications.



HPLC Connections

ProteCol Unions (stainless steel or PEEK) are combined with reusable PEEK ferrules, facilitating connecting any combination of 0.36 mm fused silica tubing, 1/32" and 1/16" PEEKsil.

- Stainless steel unions can be finger tightened or tightened with a 3/16" wrench for high-pressure applications.
- PEEK unions can be finger tightened. They are slightly larger than stainless steel unions but also lighter for less stress on your tubing.



EasyLok

EasyLok connections comprise of a knurled stainless steel nut and a double ended PEEK ferrule. The PEEK ferrule slides over any 1/16" OD tubing to its required position, while the nut is finger tightened. Unlike stainless steel, the PEEK ferrule will not crush the tubing and can be easily readjusted for quick column changes. The unique double ended ferrule design seals at two points to prevent leaks.



The fittings are compatible with any standard female HPLC fitting including Swagelok®, Parker™, Waters®, Valco® and Whatman®.

Hexnut

Ideal for applications where corrosive solvents are being used, Hexnuts have inert contact surfaces, making them biocompatible. Stainless steel 10-32 thread fittings use a non-swaging Kel-F® or PEEK replaceable ferrule.



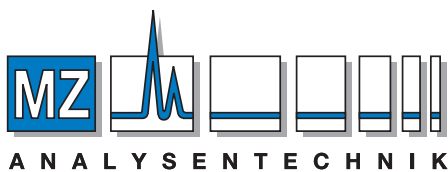

AUTHORIZED DISTRIBUTOR

MZ-Analysentechnik GmbH, Barcelona-Allee 17 • D-55129 Mainz

Tel +49 6131 880 96-0, Fax +49 6131 880 96-20

e-mail: info@mz-at.de, www.mz-at.de

AUSTRALIA & PACIFIC REGION

SGE Analytical Science Pty Ltd
7 Argent Place, Ringwood
Victoria 3134 Australia
Toll Free: 1800 800 167
Tel: +61 (0) 3 9837 4200
Fax: +61 (0) 3 9874 5672
Email: support@sge.com

JAPAN

SGE Japan Inc
RK CUBE 3F 6-85, Ohta-machi
Naka-Ku, Yokohama-shi
Kanagawa 231-0011 Japan
Tel: +81 45 222 2885
Fax: +81 45 222 2887
Email: japan@sge.com

EUROPE

SGE Europe Ltd
European Head Office
1 Potters Lane
Kiln Farm Milton Keynes
MK11 3LA United Kingdom
Toll Free: 00800 2790 8999
Toll Free Fax: 00800 2626 2609
Tel: +44 1908 568 844
Fax: +44 1908 566 790
Tel France: +33 1 69 29 80 90
Fax France: +33 1 69 29 09 25
Tel Germany: +49 (0) 6155 / 60746 0
Fax Germany: +49 (0) 6155 / 60746 50
Email: europe@sge.com

UNITED STATES OF AMERICA

SGE Incorporated
2007 Kramer Lane
Suite 100
Austin Texas 78758 USA
Toll Free: (800) 945 6154
Tel: +1 512 837 7190
Fax: +1 512 836 9159
Email: usa@sge.com

