

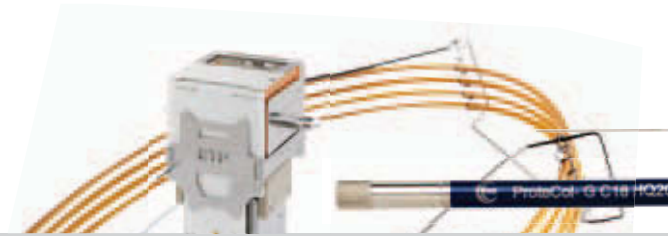

SGE Product Selection Guide | 50 Years Edition





Welcome to the SGE Product Selection Guide '50 Years' Edition



In this 50th year as a company, SGE Analytical Science reflects proudly on the growth and success of the business since its founders Ernest and Nola Dawes established Scientific Glass Engineering in a tiny garage of a house in Melbourne, Australia. Today, SGE has two modern facilities engaged in developing and manufacturing Chromatography, Mass Spectrometry and Analytical Products. The company employs over 400 people and has a global distribution and support network. We are proud that all major analytical science instrument manufacturers rely on and incorporate SGE manufactured components in their systems. SGE has a commitment to quality and is an ISO9001 accredited company. SGE is heavily

committed to ongoing research and development that will allow the company to continue to bring innovative technologies and solutions to the scientific community.

SGE Capability – Creating Solutions

SGE has a unique capability to create solutions for its analytical science customers. Through the exceptional understanding and knowledge of chromatography gained over five decades, coupled with the innovative thinking of its design and production engineers, SGE has developed world leading manufacturing processes.

SGE manufactures over 5,000 different products, utilizing tens of thousands of components incorporating hundreds of different processes. We take routine engineering processes such as machining, forming, molding, centreless grinding, laser drilling and welding, deactivation processes,





coatings and tubing; and refine these to create products that meet customer needs.

For example, SGE is one of only a handful of companies that draw our own silica and is the only company that has the ability to manufacture PEEK™ (polymer) lined fused silica tubing - PEEKsil™. Most importantly, however, is that our vertical design and manufacturing capabilities allow us to create bespoke solutions to meet our customer's needs.

It's this design and manufacturing capability that sets SGE Analytical Science apart from other companies. We are confident you will find the product you're looking for in this selection guide, but if you don't, contact us to see if we can customize a solution for you.

About the SGE Product Selection Guide

The '50 years' edition of the SGE Product Selection Guide is the complete reference for

finding, understanding and selecting the best product to meet your particular needs. It's never been easier to select the right product and have technical performance data at your fingertips. To share our expertise with you, handy expert tips have been included throughout the guide. This is an exciting time for SGE with the introduction of the Diamond Syringe range, enhancements to our GC inlet liner range, the launch of eVol® - the world's first digital analytical syringe, and other new technologies. These new products can all be found in the What's New section. In this guide we have added industry specific pages so you can find which products or applications are relevant to your work. Plus we've created a new reference section with helpful information in one place – a guide for GC, HPLC method development and troubleshooting, and a useful list of industry associations. You will find applications by industry in the GC and HPLC column sections. You can also view the guide as a searchable electronic book at www.sge.com/selectionguide

How to Order SGE Products

When ordering, please have this information ready:

- Part number.
- Description.
- Quantity.
- Purchase order number.

To order from SGE directly:

- Global SGE office addresses and contact details are listed on the back cover.

To order from your preferred SGE distributor:

- Our authorized distribution partners' addresses and contact details are listed on the SGE web site www.sge.com/contact

To order online:

- Visit www.sge.com/labcart

	Page		Page		Page
Welcome	2-3	PerkinElmer Instruments	50	BPX50	92
SGE and your Industry	7	CTC Analytics	51	70% Cyanopropyl Polysilphenylene-siloxane	
Environmental	8	CTC PAL-XT and XCHANGE®	51	BPX70	92-93
Food, Flavor, Fragrance	9	Spark Holland Instruments	52	90% Cyanopropyl Polysilphenylene-siloxane	
Fuels & Petrochemicals	10	Waters Instruments	52	BPX90	93
General Chemistry	11	LC Pump High Capacity Syringes	53	Polyethylene Glycol (PEG) in a Sol-Gel matrix	
Forensic	12	Instrument Syringes	54	SolGel-WAX™	94
Life Sciences	13	1 - 100 mL PTFE Tipped Plunger	54	Polyethylene Glycol	
Pharmaceutical	13-14	General - Replacement for Hamilton Pump Syringes	55	BP20 (WAX)	94-95
What's New	15	Shimadzu Total Organic Carbon Analyzer - TOC5000	56	Polyethylene Glycol (PEG) – TPA Treated	
Diamond Syringe Technology	16-17	Special Purpose Syringes	57	BP21 (FFAP)	95-96
XCHANGE®	18	MEPS™ - Micro Extraction by Packed Sorbent	57	14% Cyanopropylphenyl Polysiloxane	
eVol®	19	eVol® MEPS™	57	BP10 (1701)	96
GC Inlet Liners	19	GC On-Column	58-59	50% Cyanopropylphenyl Polysiloxane	
SilFlow™	20	0.5 L to 2 L Jumbo	60	BP225	97
SilTite™ FingerTite Ferrules	20	Gas Sealing Gland	61	Cyanopropylphenyl Polysiloxane	
eVol® and Accessories	21	Headspace/Soil Gas	62	BPX-VOLATILES	97
eVol® – Digitally Controlled Analytical Syringe	22	High Pressure	62	Cyanopropylphenyl Polysiloxane	
eVol® MEPS™	23	Syringe Accessories	63	BP624	98
eVol® NMR Edition	23	Repeating Adaptor (RAX)	63	Permethyated Beta-Cyclodextrin (Chiral)	
eVol® XCHANGE® and eVol® MEPS™ Syringes	24	Syringe Racks	63	CYDEX-B™	98
Alternative Replacement Needles	24	Needle Cleaning Kit	64	GC Applications by Industry	99-146
Accessories for eVol®	24	Stylet Wires	64	GC Supplies	147
Syringes and Accessories	25	Replacement Guide	65-69	Injector to Detector	148-149
Syringe Selection and Technical Information	26-34	Cross Reference Guide	70-72	Septa	150-151
General Purpose Manual Syringes	35	GC Capillary Columns	73	GC Inlet Liners	151-157
0.5 - 5 µL NanoVolume	35	SGE GC Capillary Column Innovation, Manufacture and Selection	74-82	Enhanced Range	151-157
5 µL and 10 µL Metal Plunger	36-37	100% Dimethyl Polysiloxane		Inlet Liner Selection	151-157
25 - 500 µL Metal Plunger	38	BP1	83	Connections, Ferrules and Unions	158
10 - 500 µL PTFE Tipped Plunger	39	BP1 PONA	84	Ferrules	158-161
1 - 100 mL PTFE Tipped Plunger	40	BPX1	84	SilTite™ FingerTite	159
Syringe Valves	41	100% Dimethyl Polysiloxane in a Sol-Gel Matrix		Unions	161-164
Syringes Pre-fitted with Syringe Valves	41	SolGel-1ms™	85	Nuts for SGE Fittings	164-165
Valve Needles	41	5% Phenyl / 95% Dimethyl Polysiloxane		Gas Purifiers for GC	165-166
SealTight™ Valves	42	BP5	86	Instrument Quick Pick Guide	167
GC Autosampler Syringes	43	5% Phenyl Polysilphenylene-siloxane		Agilent Technologies	167-170
Agilent Instruments	43	BPX5	87-88	PerkinElmer	170-172
CTC Analytics	44	5% Phenyl Polycarborane-siloxane		Shimadzu	172-174
CTC PAL-XT and XCHANGE®	45	HT5	89	Thermo Scientific	175-177
Shimadzu Instruments	45	8% Phenyl Polycarborane-siloxane		Varian / Bruker	177-180
PerkinElmer Instruments	46	HT8	90	ATAS Optic Injectors	180
Thermo Scientific Instruments	46	35% Phenyl Polysilphenylene-siloxane		GC Accessories	181
Bruker/Varian Instruments	47	BPX35	90-91	SilFlow™	182-184
LC Manual Syringes	48	35% Phenyl Polysilphenylene-siloxane		Splitters	184-187
Beckman/Altex, Rheodyne, SSI Instruments and Valco Valves	48-49	BPX608	91	Micro-control Valves	188-191
LC Autosampler Syringes	50	50% Phenyl Polysilphenylene-siloxane		Cold Traps	192
Hitachi Instruments	50				

	Page		Page
Cryogenic Cold Trap	192	Capillary Electrophoresis Tubing	233
Capillary Washing/Coating Reservoir	193	PEEKsil™ Tubing	234-235
Flame Ionization Detector (FID)	194	GLT™ (Glass Lined Tubing)	236-237
Capillary Cutting Tools	195	Stainless Steel Tubing	238
Retention Gap Kits	195	Terry-Tool Tubing Cutter	238
Gas & Vapor Field Sampler	195	Electron Multipliers	239
Soap Bubble Flow Meters	195	Introduction to ETP Electron Multipliers	240-241
HPLC Columns and Applications	197	Selection by Technique:	
Choosing the Right HPLC Column for Your Application	198-202	GC-MS	242
HPLC Column Selection Tree	203	LC-MS	242
ProteCol™ Product Range	204-206	ICP-MS	242
ProteCol™ HPLC Analytical Columns	204	TOF-MS	243
ProteCol™ HPLC Capillary Columns	205	Magnetic Sector	243
ProteCol™ HPLC Capillary Trap Columns	205	Selection by Instrument	243-244
ReproSil™ HPLC Capillary Trap Columns	205	Method Development and Troubleshooting	245
ProteCol™ HPLC Guard Columns	206	GC Method Development	246-249
ProteCol™ HPLC Capillary Guard Columns	206	GC Troubleshooting	250-251
HPLC Applications by Industry	207-215	HPLC Method Development	252
HPLC Supplies and Accessories	217	HPLC Troubleshooting	253-254
MEPS™ Micro SPE	218-221	Industry Associations	255
ProteCol™ In-Line Filters	222	Environmental	256
In-line Filter	222	Food, Flavor, Fragrance	256
PEEKsil™ Tubing Kits	222	Pharmaceutical	256
PEEKsil™ Injection Loop	223	Forensic	257
EasyLok™ Fittings	223	Fuels & Petrochemicals	257
Hexnut™ Fittings	223	General Chemistry	257
HPLC Column Replacement Frits	224	Life Sciences	258
ProteCol™ Unions, Ferrules and Fittings	224-225	Chromatography	258
High Efficiency HPLC Column Couplers	225	Mass Spectrometry	258
Detector/Tubing Unions	225	Index	259
ProteCol™ Accessory Kit	226	Alphabetical Index	260-266
Guard Cartridge Systems	226	Part Number Index	267-274
Solvent Filter	227	Chromatogram Index:	
SilFlow™ - New Splitter Technology	227	GC Applications	275-277
Tubing	229	HPLC Applications	277
Fused Silica Tubing	230		
High Temperature Polyimide Coating	230		
Acrylate Coating	230		
Fused Silica Stability	231		
Non-Deactivated Fused Silica	231		
Deactivated Fused Silica Tubing	232		
Methyl Deactivated Fused Silica Capillary Tubing	232-233		
Phenyl Deactivated Fused Silica Capillary Tubing	233		

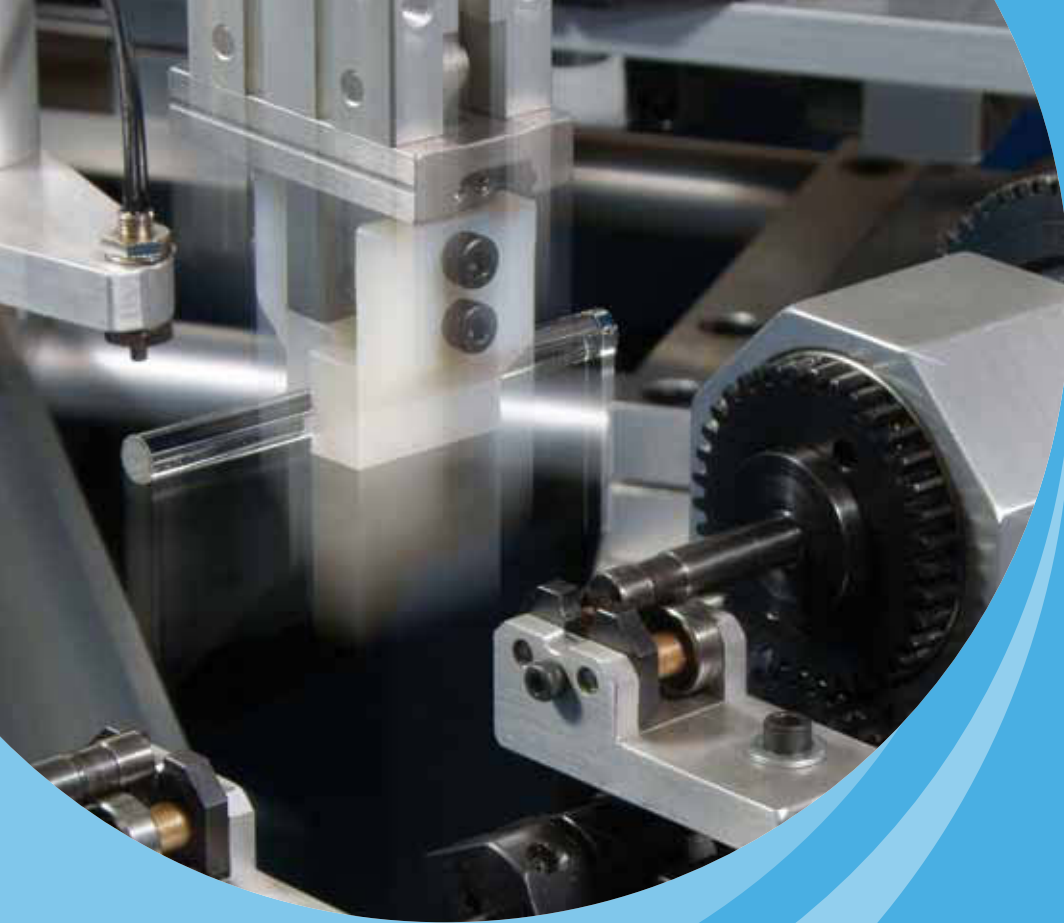

SGE and your Industry

Environmental	8
Food, Flavor, Fragrance	9
Fuels & Petrochemicals	10
General Chemistry	11
Forensic	12
Life Sciences	13
Pharmaceutical	13-14



Environmental analyses detect and quantify pollutants in air, water, soil, food, biological samples and waste with the aim of protecting the environment, ensuring safety or meeting regulatory standards. A range of analytical methods are required to test diverse substances from organic pollutants through to heavy metals.

SGE and Environmental Analyses

The widespread use of GC-MS for environmental analyses requires GC capillary columns with both low bleed and inertness characteristics. The broad range of compounds being analyzed means that medium polarity phases are particularly useful. SGE's BPX5, BPX35 and BPX50 GC columns provide a range of polarities, all with low bleed, high temperature limits and

robustness. For example, the BPX50 GC column is recommended for the analysis of PAHs while BPX35 is a good choice for herbicides. For specialized applications such as PCBs, the SGE HT8 GC column delivers unique separation capabilities. BPX Volatiles GC column is specifically designed for volatiles analysis. Dioxin separations require extremely low bleed GC columns such as SGE's BPX5.

Environmental applications are provided in the GC and HPLC column sections, see pages 99-112 and 211.

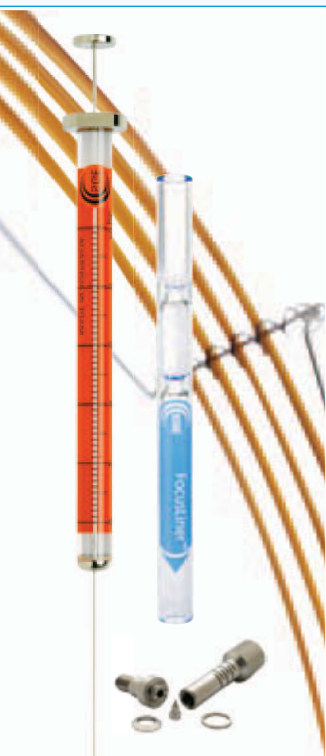

Customer Story



UNEP

SGE is pleased to be a participant in a project run by the United Nations Environment Program (UNEP). The mission of UNEP is to provide leadership and encourage partnership in caring for the environment by inspiring, informing and enabling nations and peoples to improve their quality of life without compromising that of future generations. UNEP runs a project that trains key analytical labs in developing countries on the analysis of POPs (Persistent Organic Pollutants) by gas chromatography. The project "Assessment of Existing Capacities and Capacity Building Needs to Analyze POPs in Developing Countries", is being run

by UNEP in collaboration with the University of Örebro in Sweden and the Institute for Environmental Studies (IVM) of VU University in Amsterdam, the Netherlands. SGE is one of the project's industry partners, assisting with identifying the project's analytical needs and arranging the supply of GC Supplies for the laboratories involved. The project has already provided this important training in China, Fiji, Ecuador, Kenya, Moldova, Vietnam and Uruguay. SGE is proud to make this contribution to assist UNEP with achieving their global environmental goals.

Makers of food, flavor and fragrance require analytical methods to help address issues such as formulation, development, processing and testing of the end product. As their products are for human use, conformance to specifications, standards and laws is critical so analyses must be rigorous and reproducible.

SGE and Food, Flavor and Fragrance Analyses

GC analysis in food, flavors and fragrance must account for compounds that vary in polarity and boiling point therefore a range of GC columns are often required. Chromatograms can be complex and any single column may not provide sufficient separation of all compounds that may be present. SGE has found that pairs of GC columns such as BPX5 and SolGel-WAX™ can be used to overcome this problem. When using multiple GC columns, using an inlet splitter such as

SilFlow™ simplifies this technique, read more on pages 182-184.

Specific to flavor and fragrance analysis, SGE's Olfactory Detector Outlet allows you to easily identify components of interest by odor or fragrance. See page 197 for more details.

For particular classes of compounds such as fatty acids, specialized GC columns are necessary. Short chain fatty acids may be analyzed as free acids on the Nitroterephthalic acid (TPA) modified Polyethylene Glycol BP21 phase. Longer chain fatty acids are usually analyzed as fatty acid methyl esters on capillary columns containing wax phases such as BP20 and SolGel-WAX™; or for more demanding applications, BPX70 or BPX90 GC columns.

Food, Flavors and Fragrances applications can be found on pages 113-123 and 212.



Customer Story



Organic Technologies, based in Ohio, is a process contractor for manufacturers needing expedited specialty products and process solutions. They specialize in GMP Nutraceuticals and Food Ingredients, Flavor Additives, Specialty Gases and Fine Chemicals. Francis Bordenkircher, Organic Technologies QC Manager, works with a variety of instrumentation and uses gas chromatography for Omega 3 Fatty Acid analysis including DHA and EPA. His lab is

now using SGE Diamond Manual Syringes to inject FAME (Fatty Acid Methyl Esters) and for standard curves. He finds the Diamond Manual Syringes last about four times longer than other syringes and this is saving Francis time and money. Francis also recently switched to SGE FocusLiners™. He had previously used another very inert liner and was pleasantly surprised by the improved results he obtained when he switched to SGE FocusLiners™. His RSD's (Relative Standard Deviations) dropped dramatically, and are about five to ten times lower than in the past! Francis is pleased with the results he is achieving with SGE products.





The analysis of fuels and petrochemical compounds is utilized throughout the product life cycle starting during the exploration phase and ending with testing the final product. With increasing interest in alternative and renewable energy sources, analysis now needs to meet the challenges of new fuel sources and bio-fuels.

SGE and Fuels / Petrochemical Analyses

For GC analysis of fuels and petrochemicals, one of the main considerations is the thermal stability of the capillary column, both physical and chemical. Column phases must have high temperature limits to allow the analysis of high boiling point compounds and columns must be able to physically withstand repeated cycling to extreme temperatures. GC columns such

as SGE's BPX1 and HT5 have been created with these demands in mind.

Where higher polarity is required, such as the separation of aromatic compounds, GC columns SolGel-WAX™ and BPX90 provide enhanced selectivity without the unnecessary sacrifice of maximum temperature limits.

For those using multidimensional GC, SilFlow™ delivers column switching technology with deactivated channels that is simple to install and provides a low dead volume connection. SGE's BPX50 GC column is widely used as the second dimension column in GC x GC analysis.

For fuels and petrochemicals GC applications, see pages 124-129.

Customer Story



ESPCI (Laboratory of Analytical, Bioanalytical and Miniaturization Science) in Paris, France, collaborated with IFP (the French Petroleum Institute), to respond to the growing need to better understand the hydro-denitrogenation process. Together they developed an analytical method for the comprehensive two-dimensional gas chromatography (GC X GC) separation and identification of nitrogen compounds in middle distillates according to their basicity. The researchers selected a non-polar x polar approach and tested different SGE GC columns as the second dimension column. The BPX50, SolGel-WAX™ and the BPX70 GC columns were preferred as they allowed separation of basic and neutral nitrogen compounds and due to

their high maximum operating temperature of 290 °C. The study revealed that the implementation of a secondary GC column with a polar phase that has free electron pairs considerably improves the separation of nitrogen compounds. They were able to quantitatively compare GC x GC-NCD with conventional gas chromatography illustrating the benefits of GC x GC and achieved an excellent correlation with results obtained by ASTM methods for the determination of basic/neutral nitrogen ratio in diesel samples.



General Chemistry is the process of separating, identifying and quantifying chemical components of naturally occurring and synthetic compounds. All industries mentioned in this selection guide use General Chemistry techniques; however, this section allows us to focus on analyses of more general chemical compounds.

Despite the advances in instrumentation and technology, separation based techniques such as chromatography, remain essential in analytical science. As a step within chromatographic analysis or on its own, sample preparation requires careful attention to ensure accurate and reproducible results.

SGE and General Chemistry Analyses

When performing general chemical analysis

using GC, a good rule of thumb is to use the lowest polarity column that provides sufficient separation. Particular classes of compounds, such as alcohols, amines or organic acids, may require thicker film phases, or specific phases such as the BPX25 or BP21 to avoid undue peak tailing.

The impact of metal chelating compounds on chromatographic results is often underestimated in HPLC. ProteCol™'s unique column hardware has a metal free flow path enabling the separation of chelating compounds such as natural products, with minimal preparation time. For more information on ProteCol™ HPLC columns see pages 202-210.

General Chemistry GC applications can be found on pages 130-140.

Customer Story

AFICIP

FORMATION CONTINUE

Mr Gonin is one of the founders of AFICIP France, a training centre for chemical companies across a range of industries. Their customers include multinational food, pharmaceutical and chemical manufacturers. AFICIP train French speakers in most chemical analyses including: GC, LC, Electrophoresis, Spectrometry UV Vis Atomic Absorption and IR.

Recently Mr Gonin has started using SGE's eVol®—the world's first automated analytical syringe. Before eVol®, he was using regular pipettes to prepare standards at 10 ppb from a mother solution of 1 g/L. To achieve the required accuracy, Mr Gonin needed to perform many serial dilutions which was time consuming and used lots of glassware

and solutions. Despite the time and effort, he often found that inaccuracy was difficult to eliminate completely due to the number of dilutions required and inaccuracy then caused errors in subsequent work. Mr Gonin also found pipettes a challenge when he needed to use hydrazine since it is not stable in aqueous solution. Since using eVol® for his standards preparation he is saving time by completing the preparation in only one step. Mr Gonin can use eVol® for volatile compounds such as hydrazine, since eVol® uses positive displacement unlike the air displacement mechanism of pipettes. Using eVol® means AFICIP now uses less glassware and solution but most important of all, they are achieving far superior accuracy. Mr Gonin sees other applications for eVol® at AFICIP. To learn about applications relevant to you, see the eVol® listing on pages 22-24.





Forensic scientists draw on their knowledge of toxicology, General Chemistry, pharmacology and clinical chemistry to aid medical or legal investigation of death, poisoning, and drug use. A forensic toxicologist determines which toxic substances are present, in what concentrations, and the probable effect of those chemicals on a person. Forensic analyses can be challenging as samples are often active compounds and basic in nature and can interact with the systems used to analyze them.

SGE and Forensic Analyses

For drugs of abuse testing a standard immunodiagnostic screen is undertaken. If the result of the screen is positive further analysis is performed to confirm the substance of abuse via GC or LC often combined with MS. The SGE range of GC and LC columns have been proven in forensic applications such as drugs of abuse – see Forensic applications pages 141-146. Active constituents in forensic samples may be present in tiny quantities such as micro- or nanograms, and in such cases Micro-Extraction by Packed Sorbent (MEPS™) can save a forensic laboratory time

and money. MEPS™ is a miniaturization of conventional SPE packed bed devices by incorporating packed sorbent incorporated within the needle in the barrel of a syringe reducing sample requirements to as little as 10 µL. More information on MEPS™ and applications are listed on pages 222-225.

Pyrolysis chromatography is a powerful analytical tool enabling a reproducible and characteristic 'fingerprint' to be generated of a non-volatile sample. The technique can be applied to such varied tasks as the identification of paints, rubbers, polymers, and fibres often required in forensics. SGE's Pyrojector provides highly reproducible pyrolysis results and is easily installed onto a wide range of GCs. More information can be found on page 198.

SGE's products adhere to rigorous specifications resulting in accurate, precise and reliable products that meet the quality demands of forensic toxicology. SGE products have robust design features providing excellent lifetimes despite the difficulties of handling and analyzing forensic samples.

Customer Story

The National Research Institute of Police Science in Japan last year published their method of rapid identification and quantification of methamphetamine and amphetamine in hair. Their method incorporated SGE's Micro-extraction by Packed Sorbent (MEPS™) as well as micro-pulverized extraction, aqueous acetylation for sample preparation prior to GC/MS analysis. Combined with a programmable temperature vaporizing technique, MEPS™ enabled the Japanese forensic scientists to inject most of the analytes in a sample at once, creating major time savings. It was determined that for this process, the MEPS™ extraction was durable for at least

300 extractions. The group achieved a total time for sample preparation and analysis of approximately one hour and accuracy within the limit of guidance issued by the US FDA. The publication citation for this toxicological analysis is: *Journal of Chromatography A*. 1216, (2009): 4063-70.

For more information on MEPS™ sample preparation technique, phase sorbent options and how it can reduce your solvent use as well as save you time and money see pages 222-225.



Biological samples, by their very nature, are incredibly complex with the number of sample components exceeding often tens of thousands of species. The range of concentrations is estimated to span 12 orders of magnitude – comparable to looking for a needle in a million tons of hay. Accordingly, methods for analysis differ widely between applications. Sample preparation plays a crucial role in the majority of applications and resolution power and sensitivity are key parameters for any analytical technique.

SGE and Life Sciences Analyses

SGE has developed a number of tools for use in life science laboratories. MEPS™

(Micro Extraction by Packed Sorbent) allows sample preparation on a very small scale when amounts of sample are limited. SGE has also developed large pore size ProteCol™ HPLC columns, which allow the separation of macromolecular samples with very sharp peak elution profiles, providing the highest sensitivity in peptide and protein analysis. Finally, SGE provides state-of-the-art TOF mass detectors that provide the speed and sensitivity necessary to analyze complex biological samples, more information can be found in the electron multiplier section, see pages 243-248.

SGE and your Industry



Customer Story

M.Sc. Lars Duelund, Lab manager at MEMPHYS - Center for Biomembrane Physics at the University of Southern Denmark, has been using eVol® to dispense different volumes of chloroform stock solutions (e.g. 25 µL then 36 µL etc) for preparing model membranes for biophysical studies and for TLC spotting. He uses eVol® in manual mode with slow dispensing speed to reproducibly spot the droplet onto the plate. Lars has found that compared

to the manual syringe he was previously using, eVol® has greater accuracy, especially when dispensing specific volumes that can be between the printed scale on the barrel of a manual syringe. He also finds he has more control over dispensed volumes, more reproducibility and he is experiencing less shoulder strain from repeat dispensing. All of these improvements are ultimately resulting in time savings that he can put back into his research. Find out more about Lars' work at his blog <http://larsduelund.wordpress.com/>



SGE and your Industry | Pharmaceutical

The development of a medication can be subdivided in a number of steps which, from an analytical chemist point of view, all offer different challenges.

1. Drug discovery/screening: high throughput analysis of chemical libraries either from the synthesis laboratory or from natural sources. Candidates are tested for purity and used for initial activity studies. For active compounds the possibility of semi-prep and preparative scale chromatography should be available.

2. Pre-clinical and clinical trials: Encouraging drug candidates are initially screened in biological assays and animal studies before being released into clinical phase I-III studies.

Phase I: screening for severe adverse effects in a small number of patients

Phase II: screening for adverse effects and evaluation of health benefits and the dose/effect ratio on a larger number of patients involving several clinical sites





Phase III: large scale studies to demonstrate statistically significant health benefits and identify low incidence side effects.

In all cases chromatography can be used to determine the drug purity and stability but also to analyze metabolites for pharmacokinetic studies. Regulatory requirements are much higher than in drug discovery and the emphasis for a HPLC column is placed on its sensitivity and robustness rather than the ability to scale up.

3. Drug manufacture: Once a drug substance is found to be effective and safe it has to be formulated for large scale manufacture. HPLC plays an important role in the QA/QC process of both raw material and finished product. Regulatory requirements here are at the highest level.

SGE and Pharmaceutical Analyses

Because regulatory bodies, for example the FDA in USA and EMEA in Europe, place ever higher requirements on drug safety, the levels at which impurities need to be quantified are being lowered. This puts pressure on the

sensitivity and specificity of analytical methods. At SGE we have developed a special inert column hardware, which in combination with high quality stationary phase material provides HPLC columns with the best peak shape and the highest sensitivity. Non-specific interactions are the biggest cause of tailing peaks and low sensitivity in reversed phase HPLC. For more information on SGE's ProteCol™ HPLC Columns see pages 202-210. HPLC applications can be found on pages 217-219.

In pharmaceutical manufacturing GC is used in residual solvent analysis. For applications on low molecular weight residual solvents using SGE's BPX-Volatiles see page 103.

SGE's medium to high polarity columns such as BPX50 are useful for higher molecular weight compounds, see application on page 142.

Inertness of the column and supplies in GC is critical in pharmaceutical science, of relevance then is SGE's unique, high temperature gas phase deactivation that ensures maximum inertness and minimal activity from SGE's GC columns and inlet liners.

Customer Story



GlobalLab is the largest group of companies in Brasil working directly in the service of the Analytical Laboratories. Within the GlobalLab group, Zay Analytical is dedicated to the development and validation of Analytical Methods for the ever growing Brazilian Pharmaceutical community. Alexandre Pedrosa, the Scientific Adviser and Laboratory Manager for Zay Analytical, recently commented on how impressed he was with the new ProteCol™-P C18 HPH (high pH) HPLC columns. Alexandre has found the high pH column property to be extremely

beneficial in his method development work. The ProteCol™-P C18 HPH125 silica column with PEEK™(inert polymer) lining, has a specially modified stationary phase which allows it to be used outside commonly recommended pH ranges. Because of this, Alexandre has been able to standardize on the ProteCol™-P HPH column across numerous methodologies and has eliminated the need to change columns when trying to perform his assays across a wide pH range. He has seen excellent lifetimes from these HPLC columns. Where he has seen degradation in performance, such as in a recently developed Fluxotine method, he was able to recondition the column and its performance was completely restored.





What's New

Diamond Syringe Technology	16-17
XCHANGE®	18
eVol®	19
GC Inlet Liners	19
SilFlow™	20
SilTite™ FingerTite Ferrules	20

SGE's patented XCHANGE® syringe undergoing precise assembly.



SGE Analytical Science Diamond Syringe Technology offers a never before seen level of **durability, clarity and accuracy** in the laboratory. SGE Diamond syringes provide:

- Longest working life in the industry.
- Improved solvent resistance.
- Greater operational temperature range.
- Reduced dead volume and carry over.

Diamond Syringe Technology – Syringe Brilliance

Durability

Glass Surface Technology

SGE's innovative technology enhancements provide a smoother glass surface finish inside the syringe. This smoother surface dramatically improves syringe life by reducing the wear on the plunger.

The images below show the inside glass surface of an SGE Diamond Syringe (A) compared to a competitor's syringe (B). These images are magnified 20 times.

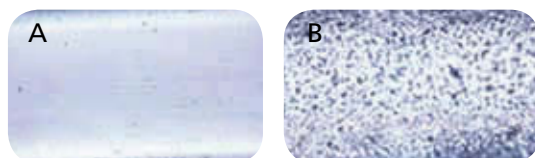

These improvements deliver improved cycle life of up to 10 times that of a similar competitors syringe.

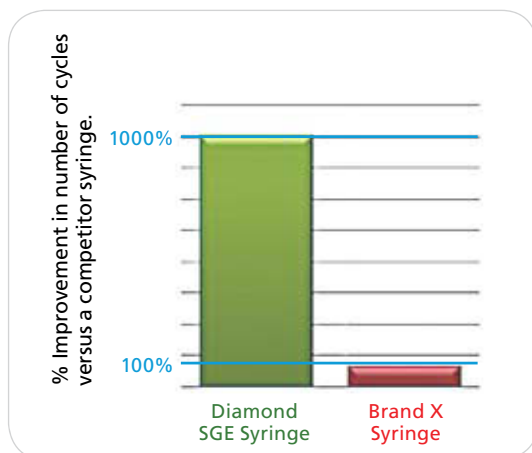

Clarity



The Diamond syringes for manual use have a bright white backing with contrasting black print for maximum readability and ease of use. The operator can easily see the scale ensuring the correct volume is delivered every time.



Autosampler and instrument syringes incorporate a vibrant new color scheme, distinguished by volume, enabling easy identification of syringes installed in instruments.

Color	Syringe Volumes			
Yellow	1000 nL (1 µL)		1 mL	1000 mL (1 L)
Grey		250 µL	2.5 mL	2000 mL (2 L)
Lime	5000 nL (5 µL)	5 µL	5 mL	
Dark Orange		10 µL	10 mL	
Green		25 µL	25 mL	
Purple		50 µL	50 mL	
Aqua		100 µL	100 mL	
Light Orange	500 nL (0.5 µL)	500 µL		500 mL (0.5 L)

Accuracy

SGE Diamond syringes offer a new level of accuracy in the laboratory. SGE syringes eliminate areas where fluid can become trapped inside the syringe and potentially cause carryover. Carryover and dead volume are reduced by:

• PTFE Plunger Tip Design

The plunger tip used in PTFE tipped syringes eliminates areas where fluid can become trapped reducing dead volume and the chance of carryover or cross contamination. The plunger tip sits flush against the syringe insert at the zero position further reducing the chance for carryover.

• **Fixed Needle Attachment Design**

A PTFE seal is added to separate fluid from adhesive (see diagram to the right). This reduces the chance of dead volume by eliminating areas where fluid can become trapped, and prevent carryover and any potential contamination from adhesives used to secure the needles, see MS traces below.

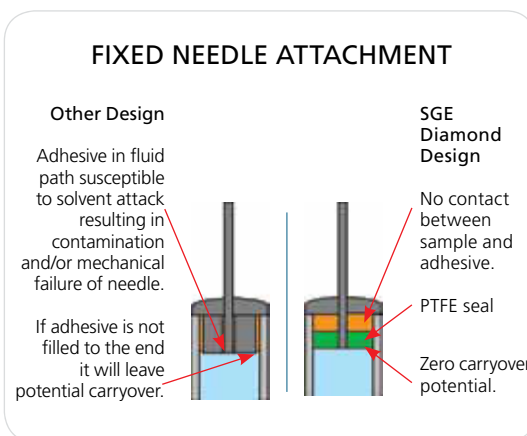

MS trace showing no adhesive contamination - SGE Diamond syringe.

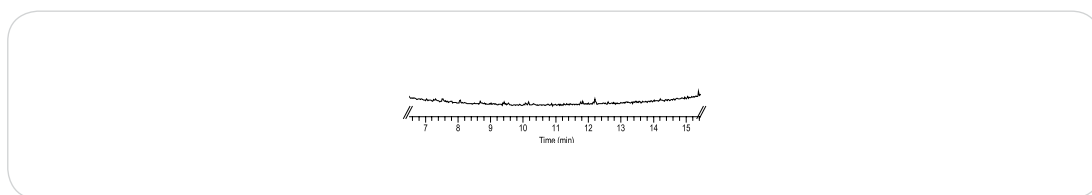

MS traces showing adhesive contamination - three syringes currently available in the market place.

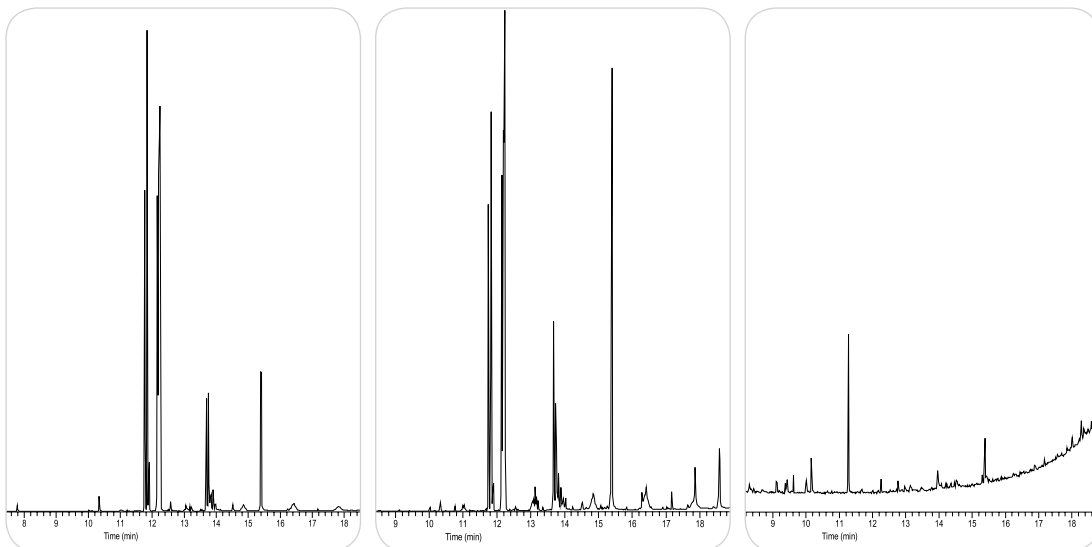

The SGE Diamond Syringe Technology improvements are proven through extensive testing and continuous monitoring by SGE's quality systems.



Syringe Packaging

SGE Diamond Syringe packaging incorporates:

- Box with window to allow easy identification of product through packaging.
- Clear 100% recyclable protective inner syringe packaging, and the outer box is fully recyclable to contribute to a reduced environmental footprint.



Patent Pending



ENABLED BY XCHANGE®

Automated – Flexible - Integrated



What Is XCHANGE®?

XCHANGE® is a coupling system that gives your robotic platform more flexibility. It allows users to change syringes and robotic tools on automated or manual systems with ease.

How Does It Work?

The XCHANGE® connection system secures and locks the syringe or tool in place. A mating mechanical piece captures the syringe or tool, and a magnet automatically aligns - eliminating the need for springs, screws, or alignment gauges.

The coupling mechanism has been designed to reduce the force required for coupling to a system that is incorporated in an instrument or robotic platform. The available force of the robot is not required for coupling.

XCHANGE® components are easily adapted to different style platforms for the ultimate flexibility and increased throughput - they can also be used on manual or semi-automated systems as a quick change option.

SGE has implemented an XCHANGE® coupling on syringes for the eVol® Digital Controlled Analytical Syringe. The XCHANGE® coupling allows syringes to easily and quickly be changed.

XCHANGE® has now been fully implemented on the CTC PAL-XT robotic platform. Testing and native firmware support ensures **robust reliability** and enables **new application possibilities** with **enhanced flexibility**.

Refer to page 45 and 51 for XCHANGE® CTC PAL-XT syringe details.

For more information on XCHANGE® on CTC PAL-XT contact CTC Analytics. www.ctc.ch



eVol® - World's First Digitally Controlled Analytical Syringe

eVol® is a complete dispensing solution with a broad range of functions and uses. eVol® revolutionizes the way laboratories work and the pace at which they process samples.



eVol®
Every One an Expert

eVol® is the coupling of two precision devices: a digitally controlled electronic drive and an XCHANGE® enabled analytical syringe (Patent Pending). The result is a digitally controlled positive displacement dispensing system that can be programmed to reproducibly and accurately perform a wide variety of liquid handling procedures.

Unlike air-displacement devices, eVol® is the perfect solution for accurately aspirating and

dispensing both aqueous and non-aqueous liquids. The range of eVol® analytical syringes can be used to accurately aspirate and dispense volumes covering from 200 nL to 500 µL.

eVol® Improves Your Laboratory Workflow and Reporting Confidence

Typical applications for eVol® include:

- Preparation of calibration standards.
- Addition of internal standards.
- Precise dispensing of aqueous and non-aqueous liquids.
- Sample dilution.

eVol® features a touch wheel user interface and a full-color screen. The menu allows all functions to be accessed logically and quickly. The programming functions are intuitive and include help screens and prompts.

For more eVol® product range details, refer to 'eVol® and Accessories' section, pages 21-24.

What's New



What's New | GC Inlet Liners

SPOT the difference in the new SGE lineup!

Choosing the right inlet liner can improve your results by up to 300 %. Do you have the right liner for your analysis? Do you find it difficult determining which inlet liner will give you the best results? Do you understand the difference between using a gooseneck or a straight liner?

To help you make the right inlet liner choice every time, SGE has made liner selection easier to understand, introducing color coding by geometry, and selection tools to facilitate your decision for the best analysis.

Each SGE inlet liner is guaranteed for deactivation, with even greater traceability



options including our Certified liners and MS Certified liners.

SGE's unique packaging guarantees contamination free liners every time. SGE inlet liners will be supplied with instrument appropriate o-rings or sealing rings, making your inlet liner purchasing easier.

For more information on SGE's enhanced inlet liners, refer to the GC Supplies section pages 151-157.



SGE's SilFlow™ micro-channel wafer technology is an innovative and user-friendly approach for flow switching and splitting applications. It delivers impressive hardware and application flexibility, expanding the capabilities of capillary gas and liquid chromatography.

This exciting new technology can benefit most analytical laboratories. From simple techniques such as connecting two detectors to one analytical column, back flushing a column, to sophisticated multidimensional separations on complex samples - SilFlow™ capabilities cover a wide range.

SilFlow™ Key Benefits:

- Allows difficult or otherwise impossible separations, delivering richer sample information than was previously unattainable.

- User-friendly design employing FingerTite™ fittings.
- User-defined oven position allows easy setup and configuration changes without the requirement of service intervention.
- Complete independence of the column from injectors or detectors giving the ability to combine injection techniques (headspace, thermal desorption, liquid, etc.), based on sample requirements.
- 15 user-interchangeable configurations delivering over 18 possible modes of operation for unparalleled application flexibility.
- Can be used on any GC with programmable pneumatic control (PPC).

For more information on SilFlow™, refer to the GC Accessories section on pages 182-185 and the HPLC Supplies and Accessories section on page 231.

What's New | SilTite™ FingerTite Ferrules



SilTite™ FingerTite is the next generation ferrule system for gas chromatography systems delivering an **easy, leak free installation** for capillary columns without the use of any tools. It is a GC ferrule that has been designed to be installed only with the force of your fingers **without the need for tools**. SilTite™ FingerTite has been developed with the unique, leak and air free properties of SilTite™ ferrules, resulting in superior air tightness to reduce background noise in sensitive MS applications.

Each starter kit includes all the parts necessary to convert one GC system (one injector and one detector) to the SilTite™ FingerTite system suitable for installing 0.1 - 0.25 mm ID capillary

columns. In addition there are 5 SilTite™ FingerTite nuts, one packet (10 ferrules) of 0.4 mm ID SilTite™ FingerTite ferrules and a ferrule install tool which allows you to seat the ferrule in the correct position on the capillary column.

The use of SilTite™ FingerTite system requires that the inlet and detector end of the GC or GCMS must be re-configured with the appropriate kit from SGE. The kit contains all parts necessary to convert either a GC or GCMS to use the new SilTite™ FingerTite ferrules. After all systems are re-configured, only one nut and one ferrule type is needed for all GC or GCMS systems. **The Smart Alternative!**

- Easy to install.
- Reliable, leak-free seal.
- Cannot be over-tightened.
- No tools required.

For more information on SilTite™ FingerTite, refer to the GC Supplies section - Ferrules, on page 159.



eVol® and Accessories

eVol® – Digitally Controlled Analytical Syringe	22
eVol® MEPS™	23
eVol® NMR Edition	23
eVol® XCHANGE® and eVol® MEPS™ Syringes	24
Alternative Replacement Needles	24
Accessories for eVol®	24

Packaging of the innovative eVol® kit.



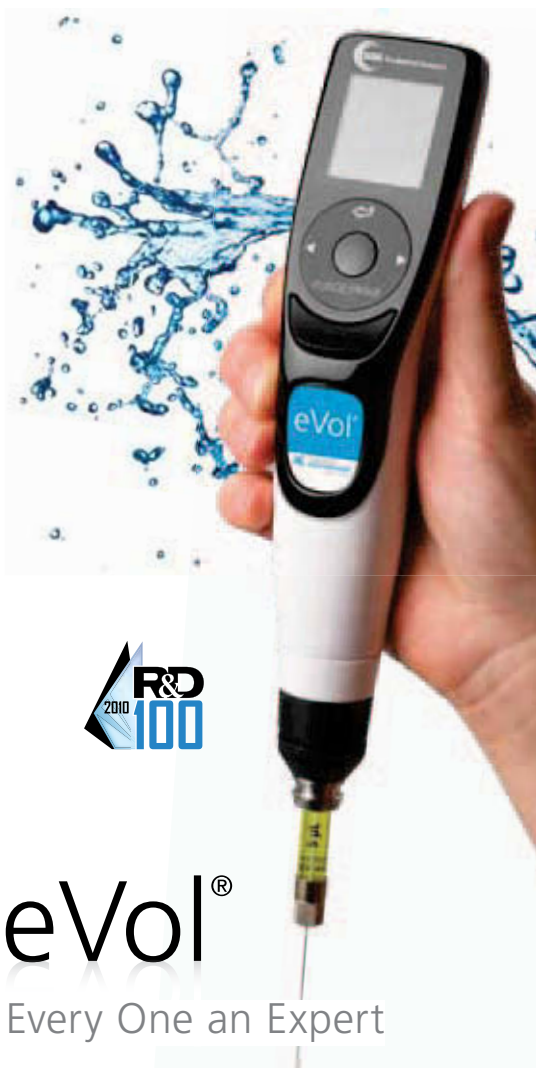

eVol® Every One an Expert

eVol® is the coupling of two precision devices: a digitally controlled electronic drive and an XCHANGE® (Patent Pending) enabled analytical syringe. Refer to page 18 for further information on XCHANGE®. The result is a digitally controlled positive displacement dispensing system that can be programmed to reproducibly and accurately perform a wide variety of liquid handling procedures.

- The programmable digital drive accurately and precisely dispenses liquids independent of the user's skills – allowing more efficient workflow scheduling and a reduction in the re-analysis of incorrectly processed or false positive samples.
- XCHANGE® analytical syringes are easily and quickly changed allowing them to be dedicated to individual liquids to prevent possible cross-contamination of reagents.
- To comply with stringent laboratory standards (e.g. GLP, GMP, FDA) eVol® is easily calibrated. eVol® is the world's first user calibrated analytical syringe. The gravimetric calibration procedure is simple, intuitive and can be performed at appropriate intervals. Calibration factors are stored for up to ten XCHANGE® syringes and quickly loaded when the syringe is changed.
- Accuracy $\pm 0.2\%$ for a calibrated syringe at full scale.
- Precision RSD (%) at full scale:
 - eVol® 500 μL syringe 0.3 %.
 - eVol® 100 μL syringe 0.3 %.
 - eVol® 50 μL syringe 0.4 %.
 - eVol® 5 μL syringe 0.5 %.



APPLICATIONS

Typical applications for eVol® include:

- Preparation of calibration standards.
- Preparation and addition of internal standards.
- Precise dispensing of aqueous and non-aqueous liquids.
- Sample dilution.
- Instrument (GC and LC) injections.
- Serial dilutions.
- Micro titrations.
- TLC spotting.
- Routine dispensing.
- Precise measurements.
- Spiking.
- Quantitative NMR.

Multiple operating modes maximize the flexibility of eVol® use:

- **Dispense** – aspirate and dispense the same volume.
- **Repeat Dispense** – repetitive dispensing of a desired volume.
- **Manual** – aspirate and dispense varying volumes (i.e. titrations).
- **Custom** – create and store methods with parameters tailored to your solution (up to 98 steps).

Custom programs can be created tailoring methods that standardize laboratory work flows, improve efficiencies, reduce variation and better utilize laboratory staff. The automation of traditionally manual processes will increase throughput and generate valuable resource savings, highly sought after in commercial laboratories.

Expert Tip :

Adjustable operational speed allows for sample variations, such as viscosity.



eVol® MEPS™



eVol® is ideal for use with MEPS™ - Micro Extraction by Packed Sorbent.

MEPS™ performs the same function as SPE, namely the purification or speciation of samples, but with the advantage that MEPS™ works with much smaller samples (as small as 3.6 µL) than full scale SPE.

eVol® and MEPS™ together offer improvements in workflow, resource savings and their combined use is ideal for method development.

The eVol® custom programming function allows MEPS™ to be automated – the sample processing, extraction and injection steps are performed using the same syringe.

The MEPS™ Barrel-Insert-Needle (BIN) contains the stationary phase and is built into the syringe needle.

The dimensions of the sorbent bed ensure that the performance remains identical to conventional SPE devices when used for extraction of similar samples.

MEPS™ BINs can easily be fitted to eVol® MEPS™ Syringes and are available in a variety of common SPE phases.

Refer to pages 222-225 for more information about MEPS™ and the range of stationary phases.

SGE is continuing to develop eVol® to include:

- Slow dispense.
- Password protection.
- More syringe options.

Contact SGE for more information.

eVol® NMR Edition

SGE has recognized the advantages eVol® brings to NMR sample preparation and has developed the 'NMR Edition' of eVol®. eVol® 'NMR Edition' improves accuracy and confidence in results, improves workflow and delivers cost savings.

eVol® 'NMR Edition' features extra long stainless steel needles (115 and 180 mm) that prevent contamination and enable 'in tube' sample dilution and mixing.

Recovery of precious samples from NMR tubes is also possible with eVol® allowing samples to be stored in cost effective vials while the NMR tubes can be emptied, washed and reused.



eVol® and Accessories



eVol® – Electronic Syringe

Description	Part No.
eVol® Electronic Syringe Starter Kit	2910000
Contains:	
<ul style="list-style-type: none"> eVol® Electronic Syringe (handle). 3 eVol® Syringes – 5 µL, 50 µL and 500 µL. Stand. 	<ul style="list-style-type: none"> Universal Charger. Comprehensive Instruction Manual. Disc with Manual in Multiple Languages.
eVol® NMR Edition	2910100
Contains:	
<ul style="list-style-type: none"> eVol® Electronic Syringe (handle). 3 eVol® Syringes – 5 µL syringe is supplied with a 115 mm needle, 50 µL and 500 µL syringes are supplied with both 115 and 180 mm needles. 	<ul style="list-style-type: none"> Stand. Universal Charger. Comprehensive Instruction Manual. Disc with Manual in Multiple Languages.
eVol® Electronic Syringe (handle only)	2910005

eVol® XCHANGE® and eVol® MEPS™ Syringes



Description	Needle Length (mm)	Needle Gauge	Needle OD (mm)	Needle ID (mm)	Needle Tip	Replacement Needle Part No.	Replacement Plunger Part No.	Syringe 3 Pack Part No.	Syringe Part No.
5 µL	50	25	0.5	0.12	Bevel	036910	2910380	2910320	2910020
5 µL (supplied without needle)	–	–	–	–	–	–	2910380	–	2910021
50 µL	50	25	0.5	0.2	Bevel	038110 ^V	2910382	2910322	2910022
50 µL (supplied without needle)	–	–	–	–	–	–	2910382	–	2910023
50 µL for MEPS™ applications*	–	–	–	–	–	–	2910382	–	2910027
100 µL	50	25	0.5	0.2	Bevel	038110	2910383	2910329	2910029
100 µL MEPS™ applications*	–	–	–	–	–	–	2910383	–	2910028
500 µL	50	23	0.63	0.32	Bevel	039110 [^]	2910384	2910324	2910024
500 µL (supplied without needle)	–	–	–	–	–	–	2910384	–	2910025
500 µL for MEPS™ applications*	–	–	–	–	–	–	2910384	–	2910026

^V All SGE 25 – 500 µL replacement needles can be used with 50 µL and 100 µL eVol® syringes. [^] All SGE 1 – 2.5 mL replacement needles can be used with 500 µL eVol® syringes. * The 50 µL, 100 µL and 500 µL eVol® MEPS™ syringes can be used with the range of MEPS™ BINs. Please refer to page 225 for the listing of available MEPS™ BINs.

Alternative Replacement Needles

Needle Length (mm)	Needle Gauge	Needle OD (mm)	Needle ID (mm)	Needle Tip	Needle Code	Pack Size	Part No.
5 µL eVol® syringe needles							
51 (2")	22	0.028"	0.17	LC	N5-5.1/22LC 5UL EVOL	5	036912
50	23	0.63	0.15	Cone	N5-5/23C 5UL EVOL	5	036914
70	25	0.50	0.20	Bevel	N5-7/25BV 5UL EVOL	5	036916
70	26	0.47	0.20	Cone	N5-7/26C 5UL EVOL	5	036918
115	25	0.50	0.20	Bevel	N5-11.5/25BV 5UL EVOL	2	036920

50 µL and 100 µL eVol® syringes can be used with all standard SGE 25-500 µL replacement needles. 500 µL eVol® syringes can be used with all standard SGE 1-2.5 mL replacement needles. Refer to pages 66 and 67 for the complete list of replacement needles.

Accessories for eVol®



Part No. 2910010
eVol® Stand



Part No. 2910012
eVol® Universal Charger



Part No. 2910040
eVol® Replacement Battery



Part No. 2910030
eVol® Charging Stand



Syringe Selection and Technical Information	26-34
General Purpose Manual Syringes:	
0.5 - 5 μ L NanoVolume	35
5 μ L and 10 μ L Metal Plunger	36-37
25 - 500 μ L Metal Plunger	38
10 - 500 μ L PTFE Tipped Plunger	39
1 - 100 mL PTFE Tipped Plunger	40
Syringe Valves:	
Syringes Pre-fitted with Syringe Valves	41
Valve Needles	41
SealTight™ Valves	42
GC Autosampler Syringes:	
Agilent Instruments	43
CTC Analytics	44
CTC PAL-XT and XCHANGE®	45
Shimadzu Instruments	45
PerkinElmer Instruments	46
Thermo Scientific Instruments	46
Bruker/Varian Instruments	47

Syringes and Accessories

LC Manual Syringes:	
Beckman/Altex, Rheodyne, SSI Instruments and Valco Valves	48-49
LC Autosampler Syringes:	
Hitachi Instruments	50
PerkinElmer Instruments	50
CTC Analytics	51
CTC PAL-XT and XCHANGE®	51
Spark Holland Instruments	52
Thermo Scientific Instruments	52
Waters Instruments	52
LC Pump High Capacity Syringes	53
Instrument Syringes:	
1 - 100 mL PTFE Tipped Plunger	54
General - Replacement for Hamilton Pump Syringes	55
Shimadzu Total Organic Carbon Analyzer - TOC5000	56
Zymark	56
Special Purpose Syringes:	
MEPS™ - Micro Extraction by Packed Sorbent	57
eVol® MEPS™	57
GC On-Column	58-59
0.5 L to 2 L Jumbo	60
Gas Sealing Gland	61
Headspace/Soil Gas	62
High Pressure	62
Syringe Accessories:	
Repeating Adaptor (RAX)	63
Syringe Racks	63
Heated Syringe Cleaner	64
Needle Cleaning Kit	64
Styler Wires	64
Replacement Guide	65-69
Cross Reference guide	70-72

Diamond syringe barrels progressing through the production process after having unique, capacity identifying colors fired on at temperatures approaching 700 °C.



Syringes and Accessories

SGE offers a complete choice in syringes with a range of capacities, termination types, and numerous needle sizes for a wide range of applications. This selection guide explains the SGE syringe features and how to select the ideal syringe for any application.

Manual, Autosampler or Instrument Syringe?

If the syringe is being used by hand, a manual syringe should be selected. If the syringe is installed in an instrument then select an autosampler syringe to suit that particular instrument.

SGE has a large range of manual syringes for use in chromatography and many other applications.

SGE's extensive range of autosampler syringes meet all fit, form and function criteria of a specific autosampler model. As minimum requirements, they meet dimensional specifications, have accuracy of better than $\pm 1\%$ * and are designed for precise, worry free overnight sampling.

What Size Syringe?

For the best possible injection reproducibility and accuracy, the smallest injectable volume from any syringe (with the exception of eVol®) should be no less than 10 % of its total capacity, for example: the smallest recommended injection volume from a 10 μL syringe would be 1 μL .

To accurately dispense 1 μL or less a Nano-Volume syringe is recommended. SGE NanoVolume syringes are available with capacities ranging from 500 nL to 5000 nL (0.5 μL to 5 μL). These syringes can inject down to 50 nL because the entire sample is contained within the needle. Designed

with submicron tolerances, these syringes are rugged, robust and reliable with virtually zero dead volume. Liquid and gas tight, they provide precision and accuracy of $\pm 2\%$.

- The typical scale length on a 0.5 μL – 10 μL syringe is 54.1 mm.
- The typical scale length on a 25 μL – 25 mL syringe is 60 mm.

Note: Scale length is sometimes referred to as stroke length.

What is Termination?

Termination refers to the interface between the syringe barrel and its mating connection such as the needle. There are several different termination options to accommodate a wide range of applications.

Many syringes are supplied and used with needles attached; there are also other terminations available: Luer Lock, Luer Tip, and threaded terminations.

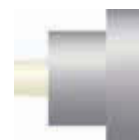

Luer Lock Termination

- For Luer Lock needles and fittings, syringe filters and pump priming.
- Specifically designed to secure Luer Lock needles.



Luer Tip Termination

- For Luer Lock needles and fittings.

Luer Lock and Luer Tip fittings are a universal fitting with a male Luer taper made from Kel-F® or PTFE to ISO standard 594. Luer Lock needles and fittings are used with syringes having Luer terminations. These syringes are often used with syringe filters and syringe pumps.

SGE offers both fixed and removable Luer Lock syringes. Fixed Luer Lock syringes have a Luer fitting that is permanently fixed to

Expert Tip :

SGE's Termination Codes:

- F Fixed Needle
- R Removable Needle
- LL Luer Lock
- LT Luer Tip



* Plunger in barrel syringes.

the barrel. If the Luer Tip is ever damaged, the syringe will need to be replaced. Removable Luer Lock syringes have fittings that screw onto the barrel with the Luer Tip inserted. Luer tips and Luer fittings can be replaced if these are damaged. Removable Luer tips need to be tightened securely to ensure they do not come loose during use.

Syringes with threaded terminations screw into a valve or other device, and are required for some LC autosamplers, syringe pumps and dispensers. There are many thread terminations possible. Contact SGE if you require a particular threaded termination that is not covered in this Selection Guide.

Which Needle?

Needle selection is based on application and personal choice.

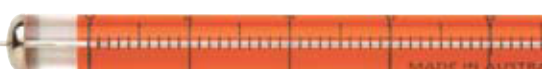

Fixed needle.



Removable needle.

Fixed Needle or Removable Needle Syringes:

Fixed needle syringes are often the preferred option for experienced operators or for applications requiring trace sample levels. A fixed needle syringe is recommended for autosampler use where the probability of needle bending is minimal. Fixed needles are easy to use and the most economical syringe option.

For versatility a removable needle syringe is recommended. The removable needle syringe reduces cost over time because only the needle needs to be replaced if bent or blocked. Removable needle syringes allow

the needle to be changed for different applications.

SGE divides its removable needles into different ranges:

- 5 μL eVol®
- 5 μL
- 10 μL
- 25 μL to 500 μL
(suitable for 50 μL eVol® Syringes)
- 1 mL to 2.5 mL
(suitable for 500 μL eVol® Syringes)
- 5 mL to 10 mL
- Luer Lock
- Valve Needles

Needles can be easily changed to meet the application need. For example: a standard 10 μL removable needle syringe can be easily converted for LC or on-column use.

Gauge or Outer Diameter (OD):

To reduce the possibility of bending, choose the largest available needle outer diameter suitable for the application. For autosamplers, syringes with 23 gauge or 0.63 mm OD cone tipped needles should be selected for all applications except on-column injection.

Inner Diameter (ID):

The ID of the needle is selected to ensure minimal dead volume without compromising the ability of the syringe to draw normal viscosity samples. Medium to high viscosity samples should be diluted prior to use or a larger inside diameter needle selected.

Expert Tip :

To maximize accuracy and reproducibility, it is recommended that the minimum volume injected from a syringe is 10% of the total syringe capacity.

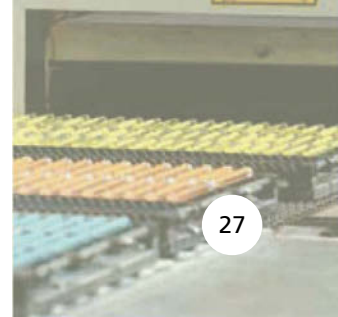



Needle Tip Styles:

SGE has a variety of needle tip styles to suit a range of applications and uses.

Bevel: Manual GC

The standard general purpose needle tip style supplied with many SGE syringes is a 20 ° bevel tip. It is the preferred option for manual injection where piercing the septum in exactly the same place is difficult. The bevel tip is designed for optimum septum penetration and prevention of septum coring. Bevel tip needles are also known as point style 2.



Cone: GC Autosampler

The cone shaped needle tip is specially developed to withstand multi injection demands and improve septum lifetime when used with an autosampler. The cone design effectively “parts” the septum during piercing instead of cutting it, as would a bevel needle. Cone tip needles are also known as point style AS for autosampler.



Dual Gauge:

Dual gauge needles have a narrow gauge at the tip suitable for megabore on-column injection. The wider gauge for the remainder of the needle gives increased strength to the needle for autosampler use.



LC: HPLC

These needles are used for LC and HPLC valve injection and have a 90 ° square tip with rounded and polished edges. This eliminates damage to the valve's rotor seal and stator face. LC/HPLC tips are also known as point style 3. This needle tip style is a good choice for general liquid dispensing.



Dome:

This style needle is recommended for use with pre-drilled septa. The tip is rounded and polished to help septum penetration.



Side Hole:

Samples are filled and dispensed through the side hole eliminating septum plugging of the needle. Ideal for large volume gas injection. The solid domed tip minimizes septum damage. Side hole/dome tips are also known as point style 5.



Sheathed/Bevel: Manual GC

This needle tip style is the same as the bevel tip, except a 0.7 mm OD reinforcing sheath is silver soldered over the standard needle to within 10 mm of the tip. The sheath provides exceptional strength to the needle. Sheathed/Bevel needles are also known as point style 4.



For your replacement needles see pages 66-67.

Custom Needles and Syringes

If you are not able to find a needle or syringe to meet your needs please contact your local SGE distributor or office for assistance.

Metal or PTFE Tipped Plunger?

A syringe with a PTFE tipped plunger should be selected when analyzing “dirty” samples such as serum and urine. The PTFE tip minimizes carryover and prevents particulate matter from getting between the plunger and barrel by effectively wiping the barrel inner diameter during the plunger stroke. PTFE tipped plungers are suitable for both liquid and gas samples. Syringes with PTFE tipped plungers have the added benefit of the plungers being replaceable as the PTFE wears due to use.

Metal plungers are individually fitted to the syringe glass barrel for a perfect “feel”, providing optimized life with minimal carry over, a liquid tight seal between the barrel and plunger and excellent performance.

SGE Plunger Options:



Metal Plunger

- Stainless steel plunger individually fitted to its own syringe barrel.
- Plunger is not replaceable.
- Industry standard syringe for chromatography applications.
- For use when injection volume is greater than 1 μL .
- Capacities: 5 μL to 500 μL



PTFE Tipped Plunger

- Suitable for both liquid and gas samples.
- Plunger is replaceable.
- Ideal for “dirty” samples.
- Suitable for gas or headspace applications.
- Easy to remove and clean to extend plunger life.
- Capacities: 10 μL to 100 mL.



NanoVolume (plunger-in-needle)

- Plunger extends into the needle tip.
- Sample is contained only in the needle, i.e. no glass contact.
- Ideal for dispensing very small liquid volumes.
- Recommended for use when sample volume is less than 1000 nL (1 μL).
- Capacities: 500 nL (0.5 μL), 1000 nL (1 μL) and 5000 nL (5 μL).



Superflex™ Flexible Plunger

- Made from Titanium/ Nickel alloy.
- Virtually indestructible plunger.
- Ideal for student use.
- Capacities: 5 μL and 10 μL .



Plunger Protection

- Extended protection at the top of the syringe back flange to help prevent plunger bending during injection and improve plunger stroke.
- Ideal for general use for both experienced and inexperienced users.
- Capacities: 5 μL and 10 μL (not necessary for capacities larger than 10 μL due to strength of the wider plunger diameter).



Guided Plunger

- Extended barrel guides plunger during injection.
- Robust and rugged.
- Ideal for student use.
- Capacities: 5 μL and 10 μL .

Special Purpose Syringes

SGE makes a range of special purpose syringes:

- On-column syringes for direct injection into a GC column.
- High-pressure syringes for applications where the syringe is exposed to elevated pressures.
- Jumbo syringes – 500 mL, 1 L and 2 L often used for air sampling.

Refer to Special Purpose Syringe section on pages 57-62.



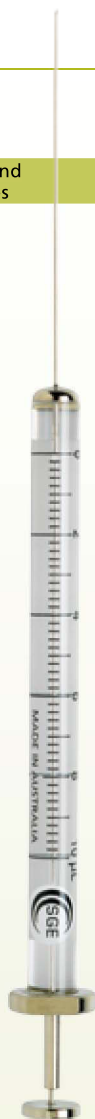

Syringe Care, Maintenance and Use

An SGE syringe is a precision instrument with a high standard of fit between the plunger and the glass barrel. Like most precision instruments, regular maintenance is important for ensuring long life and robust performance.

Syringes should be routinely checked for damage to the barrel and needle. Look for fine cracks in the barrel. Needles should also be checked for burrs and rough surfaces which may cause tearing and excessive wear on the septum.

Syringe Cleaning

Syringe cleaning agents will usually depend on the contaminating material. Methanol, methylene chloride, acetonitrile and acetone are commonly used.



Do not immerse the entire syringe in solvent as this may damage the adhesive used to bond parts of the syringe. Clean externally by wiping with a tissue.

Syringe Cleaning Steps:

1. Rinse thoroughly with suitable solvent.
2. Rinse with distilled water.
3. Flush with acetone.
4. Remove plunger and wipe with tissue.
5. Refit plunger and flush with acetone.
6. Allow syringe to dry.

Cleaning Steps for NanoVolume syringes can be found in the manual supplied with the syringe.

SGE Syringe Temperature Specifications

Heating will remove semi-volatile material from the syringe. Before heating or autoclaving remove the plunger.

- Fixed Needle and Fixed Luer Syringes can be heated in an oven to 70 °C.
- Removable Needle and Removable Luer Syringes can be heated in an oven to 120 °C.
- NanoVolume Syringes can be heated in an oven to 70 °C.

Rapid changes in temperature can lead to splitting of the glass barrel. Ensure heating and cooling of a syringe is a gradual process.

Plunger Care

Metal Plungers for Standard Syringes

- Never force the plunger.
- Do not pump the plunger when the needle is blocked as the high pressure generated could crack the barrel.
- Replacement metal plungers are not available. Plungers are individually fitted to the barrels to achieve a perfect seal. This means that plungers are not interchangeable.
- Avoid unnecessary movement of plungers when the syringe is dry.

Metal Plungers for NanoVolume Syringes

- Always loosen needle cover nut before removing or inserting plunger.
- Wipe plunger with a lint-free tissue before replacing into the syringe.

Expert Tip :

For best syringe life, ensure your syringe is rinsed 5 to 10 times with clean solvent after use.



PTFE Tipped Plungers

- Avoid unnecessary movement of plungers when syringes are dry.
- Replacement PTFE tipped plungers are available.

Needle Care

Unblocking needles:

1. To unblock the needle, remove the plunger and fill the syringe with solvent using another syringe.
2. Insert plunger and gently push solvent through the needle. Never force the plunger as too much pressure may crack the syringe barrel.

Needle Cleaning Kit



Needle Cleaning Kit (Part No. 031782):

The kit contains a range of stylet wires for needle cleaning, tweezers and a surfactant material for barrel cleaning (see page 64).

Syringe Use

- Always inspect the syringe before use. Check the barrel for cracks and the needle tip for burrs.
- To eliminate carryover between samples, flush the syringe with solvent 5-20 times, remembering to discard at least the first 2-3 washes.
- To eliminate air bubbles from the barrel, repeatedly draw and expel sample while keeping the needle tip immersed in the solution. Bubbles can also be removed by turning the barrel upright while expelling some of the sample. If bubbles persist, slow the aspiration speed.
- To make an injection, overfill the syringe then press the plunger until the correct volume is reached. Draw the plunger back slightly then wipe the needle tip with a lint free tissue. Make injection. For improved precision, syringes can be fitted with a repeating adaptor, which allows the volume to be preset on the syringe.
- Before storage always rinse the syringe with clean solvent and air dry.

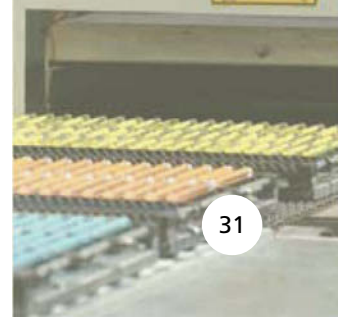

Syringe Structure

Syringes and Accessories

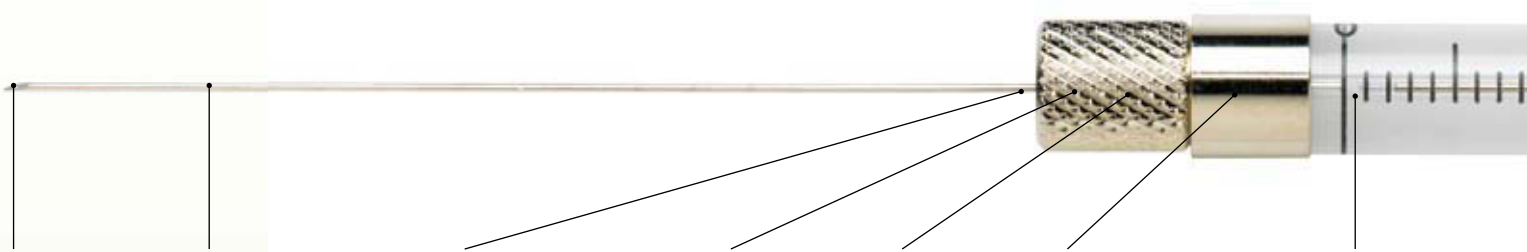

Needle Tip
A range of tip styles are available. This makes SGE syringes suitable for a wide range of applications. See page 28.

Needle
Stainless steel needles for robustness and corrosion resistance. Fixed and removable needle options in a wide range of lengths and diameters.

Removable Needle
Needles can be replaced if bent, blocked or broken without the need to replace the entire syringe.

Needle Seal / Spring/Hub
For replacement seals see page 68.

Knurled Front Cover Nut
For replacement cover nuts see page 68.

Front Screw or Needle Cap
Made from Nickel plated brass, protects the syringe barrel from chipping and breakage.

Plunger Tip
PTFE or metal.

Syringe Barrel Internal Diameter (ID)

When using a syringe pump the internal diameter of the syringe barrel is required to calculate the pumping speed. The table below lists the internal diameters of SGE syringes based on volume.

Syringe Volume	5 µL	10 µL	25 µL	50 µL	100 µL	250 µL	500 µL	1 mL
Internal Diameter of Syringe Barrel (mm)	0.343	0.485	0.728	1.030	1.457	2.303	3.257	4.606

Syringe Volume			2.5 mL	5 mL	10 mL	25 mL	50 mL	100 mL
Internal Diameter of Syringe Barrel (mm)			7.284	10.30	14.57	23.03	27.50	34.99

Please note due to variations in scale length some autosampler syringes have different internal diameters than those listed here.

**Backing Strip and Scale**

Backing strip minimizes error when reading off scale.

Scale is sharp, clear and easy to read – maximizes accuracy and precision.

Bright white backing with black scale markings on manual syringes for accurate reading of the syringe scale.

Color by volume on autosampler syringes for easy identification of installed syringes.

Barrel

Made from borosilicate glass for robustness and solvent resistance.

Back Flange

Shape provides stability and prevents syringe rolling away, made from nickel plated brass to resist fracture.

Plunger Protection

Guides the plunger into the syringe. Helps to prevent plunger bending.

Plunger Stem

Plunger Button
Designed for easy syringe use or to fit appropriate autosampler.

Syringe Troubleshooting

Problem	Cause	Solution
Blocked Needles	Improper cleaning.	Refer to syringe cleaning tips (page 30).
	Inappropriate needle selection.	Refer to needle selection guide (page 27).
Seized Plungers	Poor dispensing technique.	Ensure correct injection technique being followed.
	A build up of dirty samples.	Ensure correct syringe cleaning procedures are being followed (page 30).
Poor Reproducibility	Syringe installed in autosampler incorrectly.	Ensure syringe installed correctly.
	Incorrect syringe selection.	Refer to selection guide (page 26), the dispensed volume should be greater than 10% of the entire syringe capacity.
	Poor operator technique.	Check that each sample is being injected in the same way.
Air Bubbles	Needle tip not fully immersed in sample or air being pulled up from sample by operator technique.	Check if any changes have been, or need to be made, to your instrument or setup (septa, injection port liner, etc).
		Repeatedly draw and expel sample while keeping needle tip immersed.
		Turning the syringe upright while expelling the sample may help in the removal of the bubble.
Leakages	Leakage around needle due to needle fitted incorrectly.	Slow down.
	No seal at plunger tip – plunger tip damaged or worn due to use or using syringe dry.	Remove and refit the needle. Check seal is in place and undamaged. Replace plunger assembly if using a PTFE tipped plunger.
Ghost Peaks	Dirty needle.	Between samples flush the syringe with solvent 5-20 times (discard at least the first 2-3 washes).
	Often thought to be due to a leaking plunger, however, most often caused by blocked needle or leaking needle seal.	Refer to syringe cleaning tips. Remove and refit the needle. Check seal is in place and undamaged.
Unable to Draw Up Liquid	No seal at plunger tip - plunger tip damaged or worn due to use or using syringe dry.	Replace plunger assembly if using a PTFE tipped plunger.

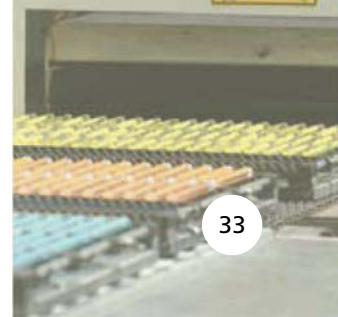

Syringe Validation and Calibration

If your laboratory is involved in GLP, ISO, GMP, NAMAS, ANSI, BSI or National Standards Protocol, then you will appreciate the importance of instrument calibration and its traceability. Although essential, this is often a time consuming, error prone and costly exercise to perform.

Certificate of Conformance

SGE supplies a syringe conformance certificate with every syringe to guarantee the syringe meets all specifications.

This syringe conformance certificate satisfies protocol requirements for syringes and provides traceability back to International Standards.

SGE syringes are produced in a manufacturing environment that operates under a quality management system that is independently certified in accordance with ISO9001:2008. All measuring equipment involved in production processes is calibrated and traceable to international standards and records are maintained. Through adherence to our quality system requirements SGE ensures that displacement volume will meet our specification for accuracy and reproducibility.

Certificate of Calibration

- Available for all SGE Syringes

SGE offers a factory calibration service, at an additional cost, for any syringe nominated by you at the time of purchase. These syringes are supplied with a Certificate of Calibration providing volume conformance and traceability. For identification each calibrated syringe is uniquely numbered and marked with this number.

To order a calibrated syringe simply add 'CAL' to the end of the part number when ordering. For example; if you require a calibration certificate for part number 002000, 10 µL fixed needle syringe; order part number 002000CAL.

SGE's eVol® – Digitally controlled analytical syringe, is the world's first user calibrated analytical syringe. Every eVol® is factory tested to ensure its operation complies with a comprehensive list of criteria. To achieve the highest level of accuracy possible each syringe may be calibrated. This will ensure your eVol® will dispense more accurately than any other manual syringe-based dispensing technique. A calibration factor for each syringe is used to adjust the software instructions controlling the motor to compensate for any slight variations in the positively displaced liquid volume. The calibration procedure for eVol® is based on a gravimetric measure of the volume dispensed from the eVol® (refer to page 22 for more details).

0.5 - 5 µL NanoVolume

With the ability to inject down to 50 nL with high precision and accuracy, SGE NanoVolume Syringes are perfect for NanoVolume capillary chromatography injection as well as making accurate standards that require small volumes.

The sample is only drawn into the needle, not the syringe barrel. When the plunger is depressed, the sample is completely dispensed by the NanoVolume plunger that extends to the tip of the needle.

Displacing the full sample during injection results in virtually zero dead volume and carry over between injections.

The plungers and needles are matched sets and must be replaced as a set. Refer to page 65 for a list of replacement plunger and needle kits.

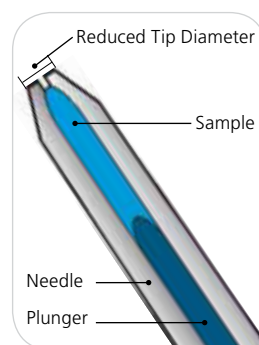

NOZZLE TIP SHOWN IN DIAGRAM.

SPECIFICATIONS	
Accuracy and Reproducibility	± 2 % (dispensed volume)
Borosilicate Glass Barrel Outer Diameter (OD)	6.5 mm and 8 mm
Scale Length	0.5 µL (6.5 mm OD barrel) = 27.05 mm, 0.5 µL (8 mm OD barrel) = 63.7 mm, 1 µL = 54.1 mm, 63.7 mm, 5 µL = 48.7 mm
International Standards Traceability	

Syringe Volume	Needle Length (mm)	Needle Gauge	Needle OD (mm)	Needle ID (mm)	Needle Tip	Syringe Code	Replacement Needle and Plunger Part No.	Syringe Part No.
6.5 mm Outer Diameter (OD) Barrel								
0.5 µL	50	23	0.63	0.155	Cone	0.5BNR-5	033010	000300
0.5 µL	50	23	0.63	0.155	Bevel	0.5BNR-5BV	033011	000301
0.5 µL	50	26	0.47	0.155	Cone	0.5BNR-5/0.47	033012	000303
8.0 mm Outer Diameter (OD) Barrel								
0.5 µL	70	23	0.63	0.1	Cone	0.5BR-7	033057	000310
0.5 µL	70	23	0.63	0.1	Bevel	0.5BR-7BV	033060	000311
1 µL	50	23	0.63	0.155	Cone	1BR-5	034055	000500
1 µL	50	23	0.63	0.155	Bevel	1BR-5BV	034056	000501
1 µL	70	23	0.63	0.155	Cone	1BR-7	034057	000505
1 µL	70	23	0.63	0.155	Bevel	1BR-7BV	034060	000506
1 µL	115	23	0.63	0.155	Cone	1BR-11.5	034059	000510
1 µL	70	26	0.47	0.155	Cone	1BR-7/0.47	034610	000570
5 µL	50	23	0.63	0.365	Cone	5BR-5	035055	000800
5 µL	50	23	0.63	0.365	Bevel	5BR-5BV	035056	000801
5 µL	70	23	0.63	0.365	Cone	5BR-7	035057	000802
5 µL	70	23	0.63	0.365	Bevel	5BR-7BV	035058	000803
5 µL	115	23	0.63	0.365	Cone	5BR-11.5	035059	000804
5 µL	70	23	0.63	0.365	Nozzle	5BR-7N	035060	000805

Syringes Fitted with Repeating Adaptor

See page 63 for more details about the RAX repeating adaptor.



Syringe Volume	Needle Length (mm)	Needle Gauge	Needle OD (mm)	Needle ID (mm)	Needle Tip	Syringe Code	Replacement Needle and Plunger Part No.	Syringe Part No.
6.5 mm Outer Diameter (OD) Barrel								
0.5 µL	50	23	0.63	0.155	Cone	0.5BNR-5-RAX	033010	000350
0.5 µL	50	26	0.47	0.155	Cone	0.5BNR-5/0.47-RAX	033012	000353
8.0 mm Outer Diameter (OD) Barrel								
0.5 µL	70	23	0.63	0.1	Cone	0.5BR-7-RAX	033057	000355
1 µL	50	23	0.63	0.155	Cone	1BR-5-RAX	034055	000550
1 µL	70	23	0.63	0.155	Cone	1BR-7-RAX	034057	000553



Syringes and Accessories

Expert Tip :

When replacing the plunger and needle follow the instructions included in the kit – the front cover nut must be loosened before removing the plunger.

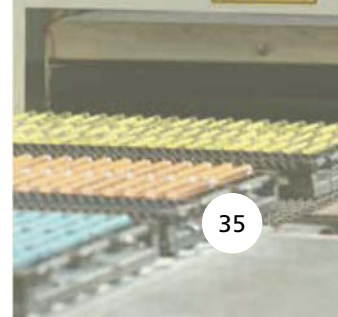

5 - 10 µL Metal Plunger

Syringes and Accessories

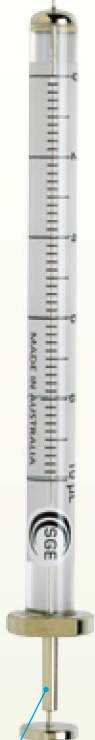

SPECIFICATIONS	
Accuracy and Reproducibility	± 1 % (dispensed volume)
Borosilicate Glass Barrel Outer Diameter (OD)	6.5 mm (guided plunger syringes 8 mm)
Scale Length	54.1 mm
International Standards Traceability	

Standard Plunger Protection Syringes

Syringe Volume	Needle Length (mm)	Needle Gauge	Needle OD (mm)	Needle ID (mm)	Needle Tip	Syringe Code	Replacement Needle Part No.	6 Pack Syringe Part No.	10 Pack Syringe Part No.	25 Pack Syringe Part No.	Syringe Part No.
Fixed Needle											
5 µL	50	26	0.47	0.11	Bevel	5F	-	-	-	-	001000
5 µL	70	26	0.47	0.11	Bevel	5F-7	-	-	-	-	001002
5 µL	42	23	0.63	0.11	Cone	5F-4.2/0.63C	-	-	-	-	001839
10 µL	50	26	0.47	0.11	Bevel	10F	-	002030	002033	002035	002000
10 µL	70	26	0.47	0.11	Bevel	10F-7	-	-	-	-	002003
10 µL	50	26	0.47	0.11	cone	10F-5C	-	-	-	-	002005
10 µL	115	26	0.47	0.11	Bevel	10F-11.5	-	-	-	-	002007
10 µL	42	23	0.63	0.11	Cone	10F-4.2/0.63C	-	-	-	-	002839
Removable Needle											
5 µL	50	26	0.47	0.11	Bevel	5R	036110	-	-	-	001050
10 µL	50	26	0.47	0.11	Bevel	10R	037110	002080	-	-	002050
10 µL	70	26	0.47	0.11	Bevel	10R-7	037130	-	-	-	002055

SuperFlex™ Syringes

Syringe Volume	Needle Length (mm)	Needle Gauge	Needle OD (mm)	Needle ID (mm)	Needle Tip	Syringe Code	Replacement Needle Part No.	6 Pack Syringe Part No.	Syringe Part No.
Fixed Needle									
5 µL	50	26	0.47	0.11	Bevel	5FX	-	-	001100
5 µL	50	26	0.47	0.11	Cone	5FX-5C	-	-	001105
10 µL	50	26	0.47	0.11	Bevel	10FX	-	002130	002100
10 µL	70	26	0.47	0.11	Bevel	10FX-7	-	-	002101
10 µL	50	26	0.47	0.11	Cone	10FX-5C	-	002133	002105
10 µL	50	23	0.63	0.11	Cone	10FX-5/0.63C	-	002135	002108
Removable Needle									
5 µL	50	26	0.47	0.11	Bevel	5RX	036110	-	001150
10 µL	50	26	0.47	0.11	Bevel	10RX	037110	002180	002150

Expert Tip :

Plunger protection helps prevent plunger bending during injection.



Expert Tip:



The virtually indestructible Titanium Nickel alloy plunger of the SuperFlex™ Syringes is ideal for student use.



Expert Tip:

Guided plunger syringes are the most rugged syringe available, making them perfect for industrial environments.

**Guided Plunger Syringes**

Syringe Volume	Needle Length (mm)	Needle Gauge	Needle OD (mm)	Needle ID (mm)	Needle Tip	Syringe Code	Replacement Needle Part No.	6 Pack Syringe Part No	Syringe Part No.
Fixed Needle									
5 µL	50	26	0.47	0.11	Bevel	5F-GP	-	-	001400
10 µL	50	26	0.47	0.11	Bevel	10F-GP	-	-	002400
Removable Needle									
5 µL	50	26	0.47	0.11	Bevel	5R-GP	036110	-	001450
5 µL	70	26	0.47	0.11	Bevel	5R-GP-7	036130	-	001455
5 µL	50	26	0.47	0.11	Bevel	5R-GPS	037110	-	001495*
10 µL	50	26	0.47	0.11	Bevel	10R-GP	037110	-	002450

* Short half scale syringe (scale length 27 mm).

**Syringes Fitted with Repeating Adaptor**

See page 63 for more details about the RAX repeating adaptor.

Syringe Volume	Needle Length (mm)	Needle Gauge	Needle OD (mm)	Needle ID (mm)	Needle Tip	Syringe Code	Replacement Needle Part No.	6 Pack Syringe Part No	Syringe Part No.
Fixed Needle									
10 µL	50	26	0.47	0.11	Bevel	10F-RAX	-	-	002040
Removable Needle									
5 µL	50	26	0.47	0.11	Bevel	5R-RAX	036110	-	001090
10 µL	50	26	0.47	0.11	Bevel	10R-RAX	037110	-	002090
Removable Needle - Guided Plunger									
5 µL	50	26	0.47	0.11	Bevel	5R-GP-RAX	036110	-	001490
10 µL	50	26	0.47	0.11	Bevel	10R-GP-RAX	037110	-	002490
10 µL	70	26	0.47	0.11	Bevel	10R-GP-7-RAX	037130	-	002493

Expert Tip :

The RAX repeating adaptor improves precision and reproducibility when repeatedly injecting the same volume manually.

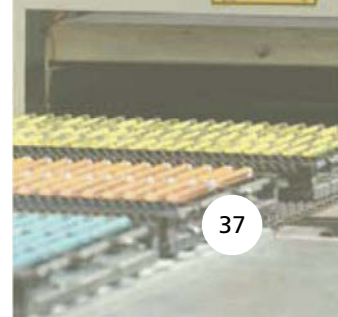

25 - 500 µL Metal Plunger

Syringes and Accessories



SPECIFICATIONS		
Accuracy and Reproducibility	± 1 % (dispensed volume)	
Borosilicate Glass Barrel Outer Diameter (OD)	8 mm	
Scale Length	60 mm	
International Standards Traceability		

Syringe Volume	Needle Length (mm)	Needle Gauge	Needle OD (mm)	Needle ID (mm)	Needle Tip	Syringe Code	Replacement Needle Part No.	Syringe Part No.
Fixed Needle								
25 µL	50	25	0.5	0.2	Bevel	25F	-	003000
50 µL	50	25	0.5	0.2	Bevel	50F	-	004000
100 µL	50	25	0.5	0.2	Bevel	100F	-	005000
250 µL	50	25	0.5	0.2	Bevel	250F	-	006000
500 µL	50	25	0.5	0.2	Bevel	500F	-	007000
Removable Needle								
25 µL	50	25	0.5	0.2	Bevel	25R	038110	003050
50 µL	50	25	0.5	0.2	Bevel	50R	038110	004050
100 µL	50	25	0.5	0.2	Bevel	100R	038110	005050
100 µL	70	25	0.5	0.2	Bevel	100R-7	038130	005055
250 µL	50	25	0.5	0.2	Bevel	250R	038110	006050
500 µL	50	25	0.5	0.2	Bevel	500R	038110	007050



Syringes Fitted with Repeating Adaptor

See page 63 for more details about the RAX repeating adaptor.

Syringe Volume	Needle Length (mm)	Needle Gauge	Needle OD (mm)	Needle ID (mm)	Needle Tip	Syringe Code	Replacement Needle Part No.	Syringe Part No.
Removable Needle								
25 µL	50	25	0.5	0.2	Bevel	25R-RAX	038110	003090
50 µL	50	25	0.5	0.2	Bevel	50R-RAX	038110	004090
100 µL	50	25	0.5	0.2	Bevel	100R-RAX	038110	005090
250 µL	50	25	0.5	0.2	Bevel	250R-RAX	038110	006090
500 µL	50	25	0.5	0.2	Bevel	500R-RAX	038110	007090

Expert Tip:

To eliminate carryover between samples, flush the syringe with solvent 5-20 times, remembering to discard the first 2-3 washes.



10 - 500 µL PTFE Tipped Plunger

SPECIFICATIONS	
Accuracy and Reproducibility	± 1 % (dispensed volume)
Borosilicate Glass Barrel Outer Diameter (OD)	10 µL = 6.5 mm, 25 - 500 µL = 8 mm
Scale Length	10 µL = 54.1 mm, 25 - 500 µL = 60 mm
International Standards Traceability	

Syringe Volume	PTFE Tipped Plunger	Needle Length (mm)	Needle Gauge	Needle OD (mm)	Needle ID (mm)	Needle Tip	Syringe Code	Replace-ment Needle Part No.	Replace-ment Plunger Part No.	6 Pack Syringe Part No.	Syringe Part No.
Fixed Needle											
10 µL	✓	50	26	0.47	0.11	Bevel	10F-GT	-	031810	002202	002200
10 µL	✓	70	26	0.47	0.11	Bevel	10F-GT-7	-	031810	-	002208
25 µL	✓	50	25	0.50	0.20	Bevel	25F-GT	-	031815	-	003200
50 µL	✓	50	25	0.50	0.20	Bevel	50F-GT	-	031820	-	004200
100 µL	✓	50	25	0.50	0.20	Bevel	100F-GT	-	031825	-	005200
250 µL	✓	50	25	0.50	0.20	Bevel	250F-GT	-	031830	-	006200
500 µL	✓	50	25	0.50	0.20	Bevel	500F-GT	-	031835	-	007200
Removable Needle											
10 µL	✓	50	26	0.47	0.11	Bevel	10R-GT	037110	031811	002252	002250
25 µL	✓	50	25	0.50	0.20	Bevel	25R-GT	038110	031815	-	003250
50 µL	✓	50	25	0.50	0.20	Bevel	50R-GT	038110	031820	-	004250
100 µL	✓	50	25	0.50	0.20	Bevel	100R-GT	038110	031825	-	005250
250 µL	✓	50	25	0.50	0.20	Bevel	250R-GT	038110	031830	-	006250
500 µL	✓	50	25	0.50	0.20	Bevel	500R-GT	038110	031835	-	007250
Guided Plunger											
10 µL	✓	50	26	0.47	0.11	Bevel	10R-GP-GT	037110	031805	-	002455
On-Column											
10 µL	✓	75	-	0.17	0.11	On-Column	10R-GT-OC-CE	037675	031811	-	002500
Fixed Luer Tip											
50 µL	✓	-	-	-	-	-	50F-LT-GT	-	031820	-	004229
100 µL	✓	-	-	-	-	-	100F-LT-GT	-	031825	-	005229
250 µL	✓	-	-	-	-	-	250F-LT-GT	-	031830	-	006229
500 µL	✓	-	-	-	-	-	500F-LT-GT	-	031835	-	007229
Fixed Luer Lock											
50 µL	✓	-	-	-	-	-	50F-LL-GT	-	031820	-	004230
100 µL	✓	-	-	-	-	-	100F-LL-GT	-	031825	-	005230
250 µL	✓	-	-	-	-	-	250F-LL-GT	-	031830	-	006230
500 µL	✓	-	-	-	-	-	500F-LL-GT	-	031835	-	007230

Syringes and Accessories



For details of Luer Lock needles and alternative needle options see pages 66-67.



1 - 100 mL PTFE Tipped Plunger

Also Suitable for Syringe Pumps and Dispensers

Syringes and Accessories



SPECIFICATIONS	
Accuracy and Reproducibility	± 1 % (dispensed volume)
Borosilicate Glass Barrel Outer Diameter (OD)	1 mL = 9 mm, 2.5 mL = 11 mm, 5 mL = 14 mm, 10 mL = 18 mm, 25 mL = 27 mm, 50 mL = 32.8 mm, 100 mL = 40.8 mm
Scale Length	1 – 25 mL = 60 mm, 50 mL = 84.2 mm, 100 mL = 104 mm
Thread in Plunger Button	6-32 UNC
International Standards Traceability	

Syringe Volume	PTFE Tipped Plunger	Needle Length (mm)	Needle Gauge	Needle OD (mm)	Needle ID (mm)	Needle Tip	Syringe Code	Replacement Needle Part No.	Replacement Plunger Part No.	Syringe Part No.
Fixed Needle										
1 mL	✓	50	22	0.72	0.37	Bevel	1MDF-GT	-	0318441	008102
2.5 mL	✓	50	22	0.72	0.37	Bevel	2.5MDF-GT	-	031852	008502
Removable Needle										
1 mL	✓	50	23	0.63	0.32	Bevel	1MR-GT	039110	031842	008100*
2.5 mL	✓	50	23	0.63	0.32	Bevel	2.5MDR-GT	039110	031852	008500
5 mL	✓	50	23	0.63	0.32	Bevel	5MDR-GT	031516	031856	008700
10 mL	✓	50	23	0.63	0.32	Bevel	10MDR-GT	031516	031862	008900
Fixed Luer Tip										
1.0 mL	✓	-	-	-	-	Luer Tip	1MF-LT-GT	-	031842	008020*
2.5 mL	✓	-	-	-	-	Luer Tip	2.5MDF-LT-GT	-	031852	008420
Fixed Luer Lock										
1.0 mL	✓	-	-	-	-	Luer Lock	1MDF-LL-GT	-	0318441	008025
2.5 mL	✓	-	-	-	-	Luer Lock	2.5MDF-LL-GT	-	031852	008425
5 mL	✓	-	-	-	-	Luer Lock	5MDF-LL-GT	-	0318562	008762
10 mL	✓	-	-	-	-	Luer Lock	10MDF-LL-GT	-	031864	008962
25 mL	✓	-	-	-	-	Luer Lock	25MDF-LL-GT	-	031874	009463
Removable Luer Lock										
5 mL	✓	-	-	-	-	Luer Lock	5MDR-LL-GT	-	031856	008760
10 mL	✓	-	-	-	-	Luer Lock	10MDR-LL-GT	-	031862	008960
25 mL	✓	-	-	-	-	Luer Lock	25MR-LL-GT	-	031870	009462
50 mL	✓	-	-	-	-	Luer Lock	50MR-LL-GT	-	0312170	009660*
100 mL	✓	-	-	-	-	Luer Lock	100MR-LL-GT	-	0312176	009760*

* No thread in plunger stem of syringe part numbers 008100, 008020, 009660 and 009760.



Syringes | Syringe Valves

Syringe valves are ideal for sample storage and transportation or to pressurize sample prior to injection.

SGE offers three basic types of manually operated syringe valves; push-pull for smaller volumes (25 µL – 2.5 mL), septum and push-button for larger volumes (5 mL – 2 L).

SGE Luer Tip, Luer Lock and removable needle syringes can be fitted with valves. The valve allows fluid to be stored in the syringe without contamination.



Push-pull Valves

Part No. 031905 Part No. 031907
 Push-pull valves suit removable needle 25 µL - 2.5 mL syringes.

Septum Valve

Part No. 031911
 The septum cap (PIN 031911) allows sample access without loss or contamination. It can be removed and Luer Lock needles or devices fitted.

Push-button Valves

Part No. 031910 Part No. 031915
 Suits 5 mL - 2 L syringes with removable Luer Lock or removable needle.
 Suitable for any Luer Lock and Luer Tip syringes or other Luer devices.

Expert Tip :
 With the valve in the closed position it is possible to move the plunger to pre-pressurize the sample.

Description	Syringe Volume	Valve Code	Replacement Needle Part No.	Valve Part No.
Push-pull Valve with Replaceable 23 Gauge Needle	25 µL - 2.5 mL	V25/2.5M-0.63C	038810	031905*
Push-pull Valve with Replaceable 26 Gauge Needle	25 µL - 2.5 mL	V25/2.5M-0.47C	038820	031906^
Push-pull Valve with Luer Lock	25 µL - 2.5 mL	VLL25/2.5M	-	031907
Push-button Valve with Luer Lock or Removable Needle	5 mL - 2 L	VLLMA	-	031910
Septum Valve	5 mL - 2 L	VLLMA5/2000	-	031911
Push-button Valve for Luer Lock Devices	50 µL - 2 L	SLLV	-	031915

* 50 mm, 0.63 mm OD cone tip needle. ^ 50 mm, 0.47 mm OD cone tip needle.



Syringes Pre-fitted with Syringe Valves

Syringe Volume	PTFE Tipped Plunger	Syringe Code	Replacement Needle Part No.	Replacement Plunger Part No.	Replacement Valve Part No.	Syringe Part No.
Pre-fitted with Removable Needle Push-pull Valve						
50 µL	✓	50R-V-GT	038810	031820	031905	004279
100 µL	✓	100R-V-GT	038810	031825	031905	005279
250 µL	✓	250R-V-GT	038810	031830	031905	006279
500 µL	✓	500R-V-GT	038810	031835	031905	007279
1 mL	✓	1MR-V-GT	038810	031842	031905	008110
2.5 mL	✓	2.5MDR-V-GT	038810	031852	031905	008510
Pre-fitted with Luer Lock Valve						
1 mL	✓	1MR-VLL-GT	-	031842	031907	008160
2.5 mL	✓	2.5MDR-VLL-GT	-	031852	031907	008560
5 mL	✓	5MDR-VLLMA-GT	-	031856	031910	008770
10 mL	✓	10MDR-VLLMA-GT	-	031862	031910	008970
25 mL	✓	25MDR-VLLMA-GT	-	031870	031910	009472
50 mL	✓	50MR-VLLMA-GT	-	0312170	031910	009670
100 mL	✓	100MR-VLLMA-GT	-	0312176	031910	009770

Valve Needles

Needle Length (mm)	Needle Gauge	Needle OD (mm)	Needle ID (mm)	Needle Tip	Pack Size	Valve Needle Part No.
For use with P/N 031905 and 031906						
50	23	0.63	0.20	Cone	1	038810
50	23	0.63	0.20	Side Hole/Dome	1	038815
50	26	0.47	0.24	Cone	1	038820

See page 67 for the complete range of Luer Lock needles suitable for use on Luer Lock valves.



SealTight™

Syringes and Accessories



SealTight™ low pressure valves are designed for improved valve seal life. SGE valves have overcome the problem of leakage by reducing perpendicular rotor force, and optimizing the rotor face union, thereby improving PTFE plug integrity. The end result is a longer life seal. The SealTight™ Valves are completely inert and enable connection of a variety of fittings. Other valves, including custom OEM configurations, are available.

SPECIFICATIONS	
Flow Path	1.5 mm (0.059")
Threaded Ports	1/4–28 UNF
Pressure Rating	120 psi
Temperature Rating	10 – 120 °C
Standard Weight	58 g
Bulkhead Weight	65 g
Breakaway Torque	0.15 Nm
Lifetime Testing	≥ 8,000 cycles

ADVANTAGES

- Extended life resulting from face rotor seal technology, making valves cost effective and reliable.
- Inert PTFE and Kel-F® flow path compatible with a variety of solvents and sample matrices.
- Easily reassembled by hand: no need to torque it up like other valves.
- Screw thread for connection onto 5 mL – 2 L syringes using syringe-valve connector (Part No. 030930).

APPLICATIONS

SealTight™ valves offer the versatility to be utilized in a variety of industries and applications:

- Dispensers.
- Diluters.
- Flow path variation.
- Biocompatible, suitable for use in pathology equipment.

Description	Mounting	Code	Part No.
Port Valves			
I flow 2 port	Standard	SV-2I/I	030200
T flow 3 port	Standard	SV-3T/T	030240
L flow 3 port	Standard	SV-3T/L	030260



I flow 2 port

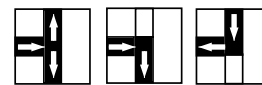

T flow 3 port



L flow 3 port

SealTight™ Valve Fittings and Connectors

Description	Code	Part No.
Kel-F® Female Luer	KSV-FL	030900
Metal Thread Male Luer Lock - PTFE Flow Path	MSV-LL	030920
Syringe-Valve Connector (fits 5 mL – 2 L syringes) PTFE Flow Path	MSV-SYR	030930
Replacement Ferrules for 1/16" Tubing	PF16-16	0730018
Replacement Ferrules for 1/8" Tubing	PF8-8	0730019



Syringes and Accessories

Agilent Instruments

SPECIFICATIONS	
Accuracy and Reproducibility	± 1 % (dispensed volume) (± 2 % for 0.5 µL and 1 µL syringes)
Borosilicate Glass Barrel Outer Diameter (OD)	0.5 µL = 6.5 mm, 1 µL = 8 mm (except P/N 000610 which is 6.5 mm) 5 µL to 250 µL = 6.5 mm
Scale Length	0.5 µL = 27.05 mm, 1 µL to 250 µL = 54.1 mm (except P/N 000610 which is 27.05 mm)
International Standards Traceability	

Syringe Volume	PTFE Tipped Plunger	Needle Length (mm)	Needle Gauge	Needle OD (mm)	Needle ID (mm)	Needle Tip	Syringe Code	Replacement Needle Part No.	Replacement Plunger Part No.	6 Pack Syringe Part No.	10 Pack Syringe Part No.	25 Pack Syringe Part No.	Syringe Part No.
HP7673, 7683, 7693A and 6850ALS Fixed Needle													
5 µL	-	42	26	0.47	0.11	Cone	5F-AG-0.47	-	-	001804	-	-	001800
5 µL	-	42	23	0.63	0.11	Cone	5F-AG-0.63	-	-	001814	-	-	001810
5 µL	-	42	23-26	0.63/0.47	0.11	Cone	5F-AG-0.63/0.47	-	-	001822	-	-	001821
10 µL	-	42	26	0.47	0.11	Cone	10F-AG-0.47	-	-	002804	-	-	002800
10 µL	-	42	23	0.63	0.11	Cone	10F-AG-0.63	-	-	002814	-	002813	002810
10 µL	✓	42	23	0.63	0.11	Cone	10F-AG-GT-0.63	-	031808	-	-	-	002812
10 µL	-	42	23-26	0.63/0.47	0.11	Cone	10F-AG-0.63/0.47	-	-	002822	-	002824	002821
10 µL	✓	42	23-26	0.63/0.47	0.11	Cone	10F-AG-GT-0.63/0.47	-	031808	002827	-	-	002826
25 µL	✓	42	23-26	0.63/0.47	0.24	Cone	25F-AG-GT-0.63/0.47	-	-	-	-	-	003668
50 µL	✓	42	23-26	0.63/0.47	0.24	Cone	50F-AG-GT-0.63/0.47	-	031142	-	-	-	004668
100 µL	✓	42	23-26	0.63/0.47	0.24	Cone	100F-AG-GT-0.63/0.47	-	031823	-	-	-	005668
HP7673, 7683, 7693A and 6850ALS Fixed Needle – SuperFlex™ Flexible Plunger													
10 µL	-	42	26	0.47	0.11	Cone	10FX-AG-0.47	-	-	002831	-	-	002830



For your optimum GC Inlet liner see the Instrument Quick Pick Guide on pages 167-180.



Syringe Volume	PTFE Tipped Plunger	Needle Length (mm)	Needle Gauge	Needle OD (mm)	Needle ID (mm)	Needle Tip	Syringe Code	Replacement Needle Part No.	Replacement Plunger Part No.	6 Pack Syringe Part No.	10 Pack Syringe Part No.	25 Pack Syringe Part No.	Syringe Part No.
HP7673, 7683, 7693A and 6850ALS Removable Needle													
0.5 µL	-	42	26	0.47	0.155	Cone	0.5BR-AG-0.47	033708*	-	-	-	-	000400
0.5 µL	-	42	23	0.63	0.155	Cone	0.5BR-AG-0.63	033715*	-	-	-	-	000410
0.5 µL	-	42	23-26	0.63/0.47	0.155	Cone	0.5BR-AG-0.63/0.47	033730*	-	-	-	-	000415
1 µL	-	42	23	0.63	0.22	Cone	1BR-AG-0.63	034715*	-	-	-	-	000610
5 µL	-	42	26	0.47	0.11	Cone	5R-AG-0.47	036710	-	-	-	-	001805
5 µL	-	42	23	0.63	0.11	Cone	5R-AG-0.63	036720	-	-	-	-	001815
5 µL	-	42	23-26	0.63/0.47	0.11	Cone	5R-AG-0.63/0.47	036730	-	-	-	-	001825
10 µL	-	42	26	0.47	0.11	Cone	10R-AG-0.47	037715	-	-	-	-	002805
10 µL	-	42	23	0.63	0.11	Cone	10R-AG-0.63	037717	-	-	-	-	002815
10 µL	✓	42	26	0.47	0.11	Cone	10R-AG-GT-0.47	037715	031809	-	-	-	002817
10 µL	✓	42	23	0.63	0.11	Cone	10R-AG-GT-0.63	037717	031809	-	002820	-	002818
10 µL	-	42	23-26	0.63/0.47	0.11	Cone	10R-AG-0.63/0.47	037730	-	-	-	-	002825
10 µL	✓	42	23-26	0.63/0.47	0.11	Cone	10R-AG-GT-0.63/0.47	037730	031809	-	-	-	002829
25 µL	-	42	23	0.63	0.24	Cone	25R-AG-0.63	038717	-	-	-	-	003665
50 µL	-	42	23	0.63	0.24	Cone	50R-AG-0.63	038717	-	-	-	-	004665
100 µL	-	42	23	0.63	0.24	Cone	100R-AG-0.63	038717	-	-	-	-	005665
250 µL	-	42	23	0.63	0.24	Cone	250R-AG-0.63	038717	-	-	-	-	006665
HP7673, 7683, 7693A and 6850ALS Removable Needle Syringes – SuperFlex™ Flexible Plunger													
10 µL	-	42	23	0.63	0.11	Cone	10RX-AG-0.63	037717	-	-	-	-	002845

* Plunger and needle replacement kit.

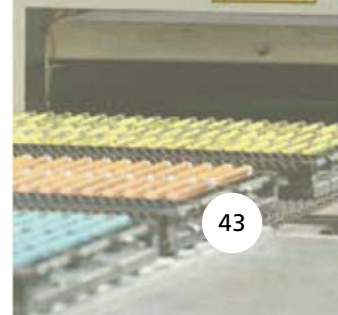

CTC Analytics

Specifications of the following syringes are matched to CTC holders to ensure proper fit and reliable functioning.

Syringes and Accessories



SPECIFICATIONS	
Accuracy and Reproducibility	± 1 % (dispensed volume) (± 2 % for 0.5 µL syringes)
Borosilicate Glass Barrel Outer Diameter (OD)	0.5 µL to 100 µL = 6.5 mm (except for P/N 003700 where OD is 8 mm), 250 µL and 500 µL = 8 mm, 1 mL = 7.6 mm, 2.5 mL = 9.7 mm
Scale Length	0.5 µL = 27.05 mm, 5 µL and 10 µL = 54.1 mm, 25 µL to 2.5 mL = 60 mm
International Standards Traceability	

Syringe Volume	PTFE Tipped Plunger	Needle Length (mm)	Needle Gauge	Needle OD (mm)	Needle ID (mm)	Needle Tip	Syringe Code	Replacement Plunger Part No.	6 Pack Syringe Part No.	Syringe Part No.
Fixed Needle										
5 µL	-	50	26	0.47	0.11	Cone	5F-CTC-5/0.47C	-	-	001700
5 µL	-	50	23	0.63	0.11	Cone	5F-C/T-5/0.63C	-	-	001981
5 µL	-	50	26	0.47	0.11	Cone	5F-C/T-5/0.47C	-	-	001982
10 µL	✓	50	26	0.47	0.11	Cone	10F-C/T-GT-5/0.47C	031803	002976	002977
10 µL	-	50	26	0.47	0.11	Cone	10F-CTC-5/0.47C	-	-	002700
10 µL	-	50	26	0.47	0.11	Bevel	10F-CTC-5/0.47BV	-	-	002705
10 µL	-	50	23	0.63	0.11	Cone	10F-C/T-5/0.63C	-	002971	002981
10 µL	✓	50	22	0.72	0.175	Side Hole	10F-CTC-GT-5/0.72H	031803	-	002983
10 µL	✓	50	23	0.63	0.11	Cone	10F-C/T-GT-5/0.63C	031803	002972	002987
25 µL	✓	50	26	0.47	0.11	Cone	25F-CTC-GT-5/0.47C	0318922	-	003700
25 µL	-	50	26	0.47	0.11	Cone	25F-C/T-0.47C	-	-	003980
25 µL	✓	50	23	0.63	0.24	Cone	25F-C/T-GT-0.63C	031817	-	003987
100 µL	✓	50	26	0.47	0.11	Cone	100F-CTC-GT-5/0.47C	0318261	-	005700
100 µL	✓	50	23	0.63	0.24	Cone	100F-C/T-GT-0.63C	0318261	-	005335
250 µL	✓	50	26	0.47	0.25	Cone	250F-CTC-GT-5/0.47C	0318926	-	006700
500 µL	✓	50	26	0.47	0.25	Cone	500F-CTC-GT-5/0.47C	0318928	-	007700
1 mL	✓	56	26	0.47	0.15	Side Hole	1MF-CTC-GT-HS-5/0.47H	0318441	-	008135
1 mL	✓	56	23	0.63	0.15	Side Hole	1MF-CTC-GT-HS-5/0.63H	0318441	-	008130
2.5 mL	✓	56	26	0.47	0.15	Side Hole	2.5MF-CTC-GT-HS-5/0.47H	0318451	-	008635
2.5 mL	✓	56	23	0.63	0.15	Side Hole	2.5MF-CTC-GT-HS-5/0.63H	0318451	-	008630

For MEPS™ syringes for CTC Analytics Autosamplers refer to page 57.



Syringe Volume	PTFE Tipped Plunger	Needle Length (mm)	Needle Gauge	Needle OD (mm)	Needle ID (mm)	Needle Tip	Syringe Code	Replacement Needle Part No.	Replacement Plunger Part No.	Syringe Part No.
Removable Needle										
0.5 µL	-	50	26	0.47	0.155	Cone	0.5BNR-C/T-0.47C	033770*	-	000490
0.5 µL	-	50	23	0.63	0.155	Cone	0.5BNR-C/T-0.63C	033772*	-	000492
2 µL	-	50	26	0.47	0.22	Cone	2BR-C/T-5/0.47C	034905*	-	000790
5 µL	-	50	23	0.63	0.11	Cone	5R-C/T-0.63C	036011	-	001984
10 µL	✓	51.5	23	0.63	0.11	Cone	10R-C/T-GT-5.15/0.63C	037013	0318121	002965
10 µL	-	50	26	0.47	0.11	Cone	10R-C/T-5/0.47C	037010	-	002982
10 µL	-	50	23	0.63	0.11	Cone	10R-C/T-0.63C	037787	-	002984
10 µL	✓	50	26	0.47	0.11	Cone	10R-C/T-GT-0.47C	037787	0318121	002985
25 µL	✓	50	26	0.47	0.15	Side Hole	25R-C/T-GT-0.47H	038749	031816	003988
25 µL	✓	50	22	0.72	0.375	Side Hole	25R-C/T-GT-0.72H	038420	031816	003989
100 µL	✓	50	26	0.47	0.2	Cone	100R-C/T-GT-0.47C	038732	031826	005333
100 µL	✓	50	23	0.63	0.24	Side Hole	100R-C/T-GT-0.63H	038736	031826	005337
250 µL	✓	50	26	0.50	0.2	Bevel	250R-C/T-GT-5/0.5BV	038110	031831	006332

* Plunger and needle replacement kit.



For your instrument specific liners see the Instrument Quick Pick Guide on 168-180

CTC PAL-XT and XCHANGE®

For more information on XCHANGE® on CTC PAL-XT contact CTC Analytics. www.ctc.ch



Syringes and Accessories

XCHANGE® CTC PAL-XT GC Autosampler Syringes

Syringe Volume	PTFE Tipped Plunger	Needle Length (mm)	Needle Gauge	Needle OD	Needle ID (mm)	Needle Tip	Replacement Needle Part No.	Replacement Plunger Part No.	Part No.
Removable Needle									
10 µL	-	56	23	0.63	0.11	Cone	037021	-	2926210
10 µL	✓	56	23	0.63	0.11	Cone	037021	2930280	2928210
25 µL	✓	56	23	0.63	0.15	Cone	038737	2930380	2928310
50 µL	✓	56	23	0.63	0.15	Cone	038737	2930480	2928410
100 µL	✓	56	23	0.63	0.15	Cone	038737	2930580	2928510
250 µL	✓	56	23	0.63	0.15	Cone	038737	2930680	2928610
500 µL	✓	56	23	0.63	0.15	Cone	038737	2930780	2928710
1 mL	✓	56	23	0.63	0.32	Bevel	039125	2930880	2928820
2.5 mL	✓	56	23	0.63	0.32	Bevel	039525	2930980	2928920
5 mL	✓	56	23	0.63	0.32	Bevel	039525	2930985	2928922

Expert Tip :

XCHANGE® syringes are removable needle syringes - change the needle to suit your application.



Shimadzu Instruments

SPECIFICATIONS	
Accuracy and Reproducibility	± 1 % (dispensed volume) (± 2 % for 0.5 µL and 1 µL syringes)
Borosilicate Glass Barrel Outer Diameter (OD)	6.5 mm
Scale Length	0.5 µL = 27.05 mm, 5 µL to 250 µL = 54.1 mm
International Standards Traceability	

Syringe Volume	PTFE Tipped Plunger	Needle Length (mm)	Needle Gauge	Needle OD (mm)	Needle ID (mm)	Needle Tip	Syringe Code	Replacement Needle Part No.	Replacement Plunger Part No.	Syringe Part No.
AOC 9 Removable Needle										
10 µL	-	50	26	0.47	0.11	Cone	10R-S(9)-0.47	037010	-	002885
AOC 14, 17, 20 and 20i Fixed Needle										
5 µL	-	42	26	0.47	0.11	Cone	5F-S-0.47	-	-	001987
5 µL	-	42	23	0.63	0.11	Cone	5F-S-0.63	-	-	001988
50 µL	-	42	23	0.63	0.24	Cone	50F-S-0.63	-	-	004682
250 µL	✓	42	23	0.63	0.24	Cone	250F-S-GT-0.63	-	031828	006682



Syringe Volume	PTFE Tipped Plunger	Needle Length (mm)	Needle Gauge	Needle OD (mm)	Needle ID (mm)	Needle Tip	Syringe Code	Replacement Needle Part No.	Replacement Plunger Part No.	Syringe Part No.
AOC 14, 17, 20 and 20i Removable Needle										
0.5 µL	-	42	26	0.47	0.155	Cone	0.5BR-S-0.47	033738*	-	000440
0.5 µL	-	42	23	0.63	0.155	Cone	0.5BR-S-0.63	033745*	-	000445
10 µL	-	42	26	0.47	0.11	Cone	10R-S-0.47	037745	-	002897
10 µL	-	42	23	0.63	0.11	Cone	10R-S-0.63	037747	-	002898
10 µL	✓	42	23	0.63	0.11	Cone	10R-S-GT-0.63	037747	031798	002902

* Plunger and needle replacement kit.

For syringes to suit the Shimadzu AOC-5000 Autosampler refer to the CTC Autosampler syringes on page 44.



PerkinElmer Instruments

Syringes and Accessories



SPECIFICATIONS	
Accuracy and Reproducibility	± 1 % (dispensed volume) (± 2 % for 0.5 µL)
Borosilicate Glass Barrel Outer Diameter (OD)	6.5 mm
Scale Length	0.5 µL and 5 µL = 27.05 mm, 50 µL = 54.1 mm
International Standards Traceability	

Syringe Volume	PTFE Tipped Plunger	Needle Length (mm)	Needle Gauge	Needle OD (mm)	Needle ID (mm)	Needle Tip	Syringe Code	Replacement Needle Part No.	Replacement Plunger Part No.	Syringe Part No.
AutoSystem and Clarus 500 Fixed Needle										
5 µL	-	70	26	0.47	0.15	Cone	5F-PE-0.47	-	-	001953
5 µL	-	70	23	0.63	0.15	Cone	5F-PE-0.63	-	-	001954
5 µL	✓	70	26	0.47	0.15	Cone	5F-PE-GT-0.47	-	031807	001955
5 µL	✓	70	23	0.63	0.15	Cone	5F-PE-GT-0.63	-	031807	001957
50 µL	-	70	23	0.63	0.24	Cone	50F-PE-0.63	-	-	004670

Syringe Volume	PTFE Tipped Plunger	Needle Length (mm)	Needle Gauge	Needle OD (mm)	Needle ID (mm)	Needle Tip	Syringe Code	Replacement Needle and Plunger Kit Part No.	Syringe Part No.
AutoSystem and Clarus 500 Removable Needle									
0.5 µL	-	70	26	0.47	0.155	Beveled Cone	0.5BR-PE-0.47	033750	000475
0.5 µL	-	70	23	0.63	0.155	Cone	0.5BR-PE-0.63	033765	000478

Thermo Scientific Instruments

SPECIFICATIONS	
Accuracy and Reproducibility	± 1 % (dispensed volume) (± 2 % for 0.5 µL)
Borosilicate Glass Barrel Outer Diameter (OD)	6.5 mm
Scale Length	0.5 µL = 27.05 mm, 10 µL = 54.1 mm
International Standards Traceability	

Syringe Volume	PTFE Tipped Plunger	Needle Length (mm)	Needle Gauge	Needle OD (mm)	Needle ID (mm)	Needle Tip	Syringe Code	Replacement Needle Part No.	Replacement Plunger Part No.	Model				6 Pack Syringe Part No.	Syringe Part No.
										TriPlus	AS3000	AS2000	AS200/800		
Fixed Needle															
5 µL	-	50	23	0.63	0.11	Cone	5F-C/T-5/0.63C	-	-	✓	-	-	-	-	001981
10 µL	-	80	23	0.63	0.11	Cone	10F-C/T-8/0.63C	-	-	✓	-	-	-	-	002989
10 µL	-	80	26	0.47	0.11	Cone	10F-C/T-8/0.47C	-	-	✓	-	✓	-	-	002992
10 µL	-	50	25	0.50	0.125	Cone	10F-C/T-5/0.5C	-	-	✓	✓	✓	✓	-	002967
10 µL	-	80	22	0.72	0.175	Cone	10F-C/T-8/22C	-	-	✓	-	✓	-	-	002974
10 µL	✓	50	23	0.63	0.11	Cone	10F-C/T-GT-5/0.63C	-	031803	✓	-	✓	-	002972	002987
10 µL	-	50	23	0.63	0.11	Cone	10F-C/T-5/0.63C	-	-	✓	✓	✓	✓	002971	002981
10 µL	-	50	26	0.47	0.11	Cone	10F-C/T-5/0.47C	-	-	✓	✓	✓	✓	002986	002980
10 µL	-	80	26	0.47	0.11	Bevel	10F-C/T-8/0.47BV	-	-	✓	-	✓	-	-	002997

Syringe Volume	PTFE Tipped Plunger	Needle Length (mm)	Needle Gauge	Needle OD (mm)	Needle ID (mm)	Needle Tip	Syringe Code	Replacement Needle Part No.	Replacement Plunger Part No.	Model				6 Pack Syringe Part No.	Syringe Part No.
										TriPlus	AS3000	AS2000	AS200/800		
Removable Needle															
0.5 µL	-	50	26	0.47	0.155	Cone	0.5BNR-C/T-5/0.47C	033770*	-	✓	✓	-	-	-	000490
0.5 µL	-	50	23	0.63	0.155	Cone	0.5BNR-C/T-5/0.63C	033772*	-	✓	✓	-	-	-	000492
2 µL	-	50	26	0.47	0.22	Cone	2BR-C/T-5/0.47C	034905*	-	✓	✓	-	-	-	000790
10 µL	-	50	26	0.47	0.11	Cone	10R-C/T-5/0.47C	037010	-	✓	✓	✓	-	-	002982
10 µL	-	50	23	0.63	0.11	Cone	10R-C/T-5/0.63C	037787	-	✓	✓	✓	✓	-	002984
10 µL	-	80	26	0.47	0.15	Cone	10R-C/T-8/0.47C	031535	-	✓	-	✓	-	-	002993

* Plunger and needle replacement kit.

The syringes for CTC Analytics Autosamplers are also suitable for Thermo Scientific Instrument, refer to page 44.

Bruker/Varian Instruments

For syringes for CTC Analytics Autosamplers, refer to page 44.

Syringes and Accessories



SPECIFICATIONS	
Accuracy and Reproducibility	± 1 % (dispensed volume) (± 2 % for 1 µL syringes)
Borosilicate Glass Barrel Outer Diameter (OD)	1 µL = 8 mm, 10 µL = 6.5 mm, 100 µL = 8 mm
Scale Length	1 µL = 54.1 mm, 10 µL = 50.7 mm (except for 002950, 002981 and 002982 which is 54.1 mm), 100 µL = 60 mm
International Standards Traceability	

Syringe Volume	PTFE Tipped Plunger	Needle Length (mm)	Needle Gauge	Needle OD (mm)	Needle ID (mm)	Needle Tip	Syringe Code	Replacement Needle Part No.	Replacement Plunger Part No.	Syringe Part No.
8035, 8100 and 8200 Series Fixed Needle										
10 µL	✓	53	25	0.5	0.125	S/Hole	10F-GT-VA8X-2	-	031218	002923
8400/8410, CP-9010/9050 Series Fixed Needle										
10 µL	-	50	26	0.47	0.11	Bevel	10F-VA8400-5/0.47	-	-	002950
10 µL	-	50	23	0.63	0.11	Cone	10F-C/T-5/0.63C	-	-	002981



Syringe Volume	PTFE Tipped Plunger	Needle Length (mm)	Needle Gauge	Needle OD (mm)	Needle ID (mm)	Needle Tip	Syringe Code	Replacement Needle Part No.	Replacement Plunger Part No.	Syringe Part No.
8035, 8100 and 8200 Series Removable Needle										
1 µL	-	51	26	0.47	0.155	Cone	1BR-VA8X	034720*	-	000655
10 µL	✓	53	25	0.5	0.125	S/Hole	10R-GT-VA8X-2	037777	031218	002924
Needle Alternatives for syringe p/n 002924	2 pack	50	25	0.5	-	Bevel	N10-VA8035-II	037776		
	2 pack	105	-	-	-	OC	N10-VA8035-0.17-II	037778		
	2 pack	53	23	0.63	-	S/Hole	N10-VA8X00H-0.63-II	037779		
	1 pack	53	25	0.5	-	S/Hole	N10-VA800H-II(0.2)	037780		
	100 µL	✓	53	25	0.5	0.125	S/Hole	100R-GT-VA8X	038745	031824
8400/8410, CP-9010/9050 Series Removable Needle										
10 µL	-	50	26	0.47	0.11	Cone	10R-C/T-5/0.47C	037010	-	002982

* Plunger and needle replacement kit.

For your instrument specific GC Inlet liners see the Instrument Quick Pick Guide pages 167-180.





Syringes and Accessories

Beckman/Altex, Rheodyne, SSI Instruments and Valco Valves

SPECIFICATIONS

Accuracy and Reproducibility	± 1 % (dispensed volume)
Borosilicate Glass Barrel Outer Diameter (OD)	5 µL and 10 µL = 6.5 mm, 25 µL to 500 µL = 8 mm, 1 mL = 8.8 mm, 2.5 mL = 10.8 mm
Scale Length	60 mm (5 µL and 10 µL are 54.1 mm)
International Standards Traceability	

Syringe Volume	PTFE Tipped Plunger	Needle Length (mm)	Needle Gauge	Needle OD (mm)	Needle ID (mm)	Needle Tip	Syringe Code	Replacement Plunger Part No.	6 Pack Syringe Part No.	Syringe Part No.
Fixed Needle										
5 µL	-	51	22	0.028"	0.17	LC	5F-LC	-	-	001301
10 µL Superflex™	-	51	22	0.028"	0.17	LC	10FX-LC	-	002330	002300
10 µL	-	51	22	0.028"	0.17	LC	10F-LC	-	002315	002301
10 µL	✓	51	22	0.028"	0.17	LC	10F-LC-GT	031810	-	002335
25 µL	-	51	22	0.028"	0.37	LC	25F-LC	-	-	003300
50 µL	-	51	22	0.028"	0.37	LC	50F-LC	-	-	004300
100 µL	-	51	22	0.028"	0.37	LC	100F-LC	-	-	005300
250 µL	-	51	22	0.028"	0.37	LC	250F-LC	-	-	006300
500 µL	-	51	22	0.028"	0.37	LC	500F-LC	-	-	007300



Syringe Volume	PTFE Tipped Plunger	Needle Length (mm)	Needle Gauge	Needle OD (mm)	Needle ID (mm)	Needle Tip	Syringe Code	Replacement Needle Part No.	Syringe Part No.
Removable Needle with Repeating Adaptor									
10 µL	-	51	22	0.028"	0.17	LC	10R-LC-RAX	037250	002345
25 µL	-	51	22	0.028"	0.37	LC	25R-LC-RAX	038250	003320
50 µL	-	51	22	0.028"	0.37	LC	50R-LC-RAX	038250	004320
100 µL	-	51	22	0.028"	0.37	LC	100R-LC-RAX	038250	005320
250 µL	-	51	22	0.028"	0.37	LC	250R-LC-RAX	038250	006320
500 µL	-	51	22	0.028"	0.37	LC	500R-LC-RAX	038250	007320

Expert Tip:

The blunt LC needle tip design and 51 mm needle length are used to avoid damage to the LC valve.



Expert Tip :

LC manual Syringes are a good choice for general liquid dispensing.





Syringe Volume	PTFE Tipped Plunger	Needle Length (mm)	Needle Gauge	Needle OD (mm)	Needle ID (mm)	Needle Tip	Syringe Code	Replacement Needle Part No.	Replacement Plunger Part No.	Syringe Part No.
Removable Needle										
5 µL	-	51	22	0.028"	0.17	LC	5R-LC	036250	-	001310
10 µL	-	51	22	0.028"	0.17	LC	10R-LC	037250	-	002310
10 µL	✓	51	22	0.028"	0.17	LC	10R-GT-LC	037250	031811	002313
10 µL	-	51	22	0.028"	0.17	LC	10RX-LC	037250	-	002350
25 µL	-	51	22	0.028"	0.37	LC	25R-LC	038250	-	003310
25 µL	✓	51	22	0.028"	0.37	LC	25R-GT-LC	038250	031815	003312
50 µL	-	51	22	0.028"	0.37	LC	50R-LC	038250	-	004310
50 µL	✓	51	22	0.028"	0.37	LC	50R-GT-LC	038250	031820	004312
100 µL	-	51	22	0.028"	0.37	LC	100R-LC	038250	-	005310
100 µL	✓	51	22	0.028"	0.37	LC	100R-GT-LC	038250	031825	005312
250 µL	-	51	22	0.028"	0.37	LC	250R-LC	038250	-	006310
250 µL	✓	51	22	0.028"	0.37	LC	250R-GT-LC	038250	031830	006312
500 µL	-	51	22	0.028"	0.37	LC	500R-LC	038250	-	007310
500 µL	✓	51	22	0.028"	0.37	LC	500R-GT-LC	038250	031835	007312
1 mL	✓	51	22	0.028"	0.37	LC	1MR-LC-GT	039250	031842	008105
2.5 mL	✓	51	22	0.028"	0.37	LC	2.5MDR-LC-GT	039250	031852	008505

Expert Tip :

Users of Valco injectors requiring 3/4" long needles, must fit a Valco VISF-2 adaptor.

**Expert Tip:**

When using the complete loop fill technique, the syringe capacity should be greater than twice the loop volume. The loop capacity sets the injection volume.

When using the partial loop technique, the injection volume should be no greater than half the loop capacity. The injection size sets the injection volume.

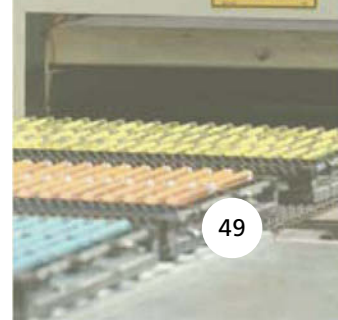



Syringes and Accessories



Hitachi Instruments

SPECIFICATIONS	
Accuracy and Reproducibility	± 1 % (dispensed volume)
Borosilicate Glass Barrel Outer Diameter (OD)	8 mm
Scale Length	No scale (60 mm stroke)
International Standards Traceability	

Syringe Volume	PTFE Tipped Plunger	Front Thread	Syringe Code	Replacement Plunger Part No.	Syringe Part No.
500 µL	✓	M10 x 1.0	500C-HITACHI	031837	007660

PerkinElmer Instruments



SPECIFICATIONS	
Accuracy and Reproducibility	± 1 % (dispensed volume)
Borosilicate Glass Barrel Outer Diameter (OD)	50 µL to 500 µL = 8 mm, 1 mL = 9 mm, 2.5 mL = 11 mm
Scale Length	60 mm
International Standards Traceability	

Syringe Volume	PTFE Tipped Plunger	Front Thread	Syringe Code	Replacement Plunger Part No.	Syringe Part No.
50 µL	✓	1/4-28 UNF	50D-CX-GT	0318221	004995
100 µL	✓	1/4-28 UNF	100D-CX-GT	0318271	005990
250 µL	✓	1/4-28 UNF	250D-CX-GT	031833	006995
500 µL	✓	1/4-28 UNF	500D-CX-GT	0318381	007995
1 mL	✓	1/4-28 UNF	1MD-C-GT	0318441	008185
2.5 mL	✓	1/4-28 UNF	2.5MD-C-GT	031854	008687

For SGE's HPLC column range see page 202-210.

CTC Analytics

SPECIFICATIONS	
Accuracy and Reproducibility	± 1 % (dispensed volume)
Borosilicate Glass Barrel Outer Diameter (OD)	10 µL to 250 µL = 6.5mm (except P/N 003715 and P/N 006720 = 8 mm) 500 µL = 8 mm, 1 mL = 7.6 mm, 2.5 mL = 9.7 mm, 5 mL = 14 mm
Scale Length	10 µL = 54.1 mm, 25 µL to 5 mL = 60 mm
International Standards Traceability	

Syringe Volume	PTFE Tipped Plunger	Needle Length (mm)	Needle Gauge	Needle OD (mm)	Needle ID (mm)	Needle Tip	Syringe Code	Replacement Needle Part No.	Replacement Plunger Part No.	Syringe Part No.
Fixed Needle										
10 µL	-	51	22	0.72	0.17	LC	10F-CTC-LC	-	-	002710
10 µL	✓	51	22	0.72	0.17	LC	10F-CTC-GT-LC	-	031803	002715
25 µL	✓	51	22	0.72	0.17	LC	25F-CTC-GT-LC	-	0318922	003715*
25 µL	-	51	22	0.72	0.37	LC	25F-C/T-LC	-	-	003984
50 µL	✓	51	22	0.72	0.37	LC	50F-C/T-GT-LC	-	031821	004810
100 µL	✓	51	22	0.72	0.17	LC	100F-CTC-GT-LC	-	0318261	005715
100 µL	✓	51	22	0.72	0.4	LC	100F-CTC-GT-LC (0.4)	-	0318261	005720
250 µL	✓	51	22	0.72	0.4	LC	250F-CTC-GT-LC (0.4)	-	0318926	006720*
500 µL	✓	51	22	0.72	0.4	LC	500F-CTC-GT-LC (0.4)	-	0318928	007720

* Please note barrel OD is 8mm.



Syringe Volume	PTFE Tipped Plunger	Needle Length (mm)	Needle Gauge	Needle OD (mm)	Needle ID (mm)	Needle Tip	Syringe Code	Replacement Needle Part No.	Replacement Plunger Part No.	Syringe Part No.
Removable Needle										
25 µL	✓	51	22	0.72	0.37	LC	25R-C/T-GT-LC	038250	031816	003985
50 µL	✓	51	22	0.72	0.37	LC	50R-C/T-GT-LC	038250	0318212	004830
100 µL	✓	51	22	0.72	0.37	LC	100R-C/T-GT-LC	038250	031826	005330
250 µL	✓	51	22	0.72	0.37	LC	250R-C/T-GT-LC	038250	031831	006330
1 mL	✓	51	22	0.72	0.4	LC	1MR-CTC-GT-LC(0.4)	039180	0318444	008120
2.5 mL	✓	51	22	0.72	0.4	LC	2.5MR-CTC-GT-LC(0.4)	039182	0318454	008620
5 mL	✓	51	22	0.72	0.4	LC	5MR-CTC-GT-LC(0.4)	0315235	031856	008820

Syringes and Accessories



CTC PAL-XT and XCHANGE®

For more information on XCHANGE® on CTC PAL-XT contact CTC Analytics. www.ctc.ch



For alternative needle options, see pages 66-67.

XCHANGE® CTC PAL-XT LC Autosampler Syringes

Syringe Volume	PTFE Tipped Plunger	Needle Length (mm)	Needle Gauge	Needle OD	Needle ID (mm)	Needle Tip	Replacement Needle Part No.	Replacement Plunger Part No.	Part No.
Removable Needle									
10 µL	-	56	22	0.028*	0.17	LC	037221	-	2926230
25 µL	✓	56	22	0.028*	0.17	LC	038259	2930380	2928330
50 µL	✓	56	22	0.028*	0.17	LC	038259	2930480	2928430
100 µL	✓	56	22	0.028*	0.17	LC	038259	2930580	2928530
250 µL	✓	56	22	0.028*	0.375	LC	038255	2930680	2928630
500 µL	✓	56	22	0.028*	0.375	LC	038255	2930780	2928730
1 mL	✓	56	22	0.028*	0.375	LC	039256	2930880	2928830
2.5 mL	✓	56	22	0.028*	0.375	LC	039556	2930980	2928930
5 mL	✓	56	22	0.028*	0.375	LC	039556	2930985	2928932

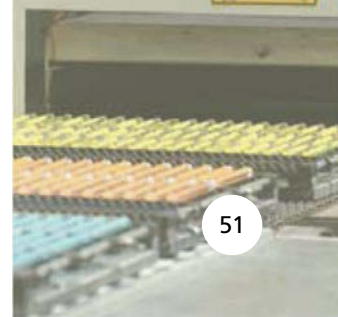

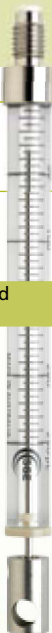

Spark Holland Instruments

SPECIFICATIONS	
Accuracy and Reproducibility	± 1 % (dispensed volume)
Borosilicate Glass Barrel Outer Diameter (OD)	250 µL = 8 mm, 1 mL = 9 mm
Scale Length	60 mm
International Standards Traceability	

Syringe Volume	PTFE Tipped Plunger	Front Thread	Syringe Code	Replacement Plunger Part No.	Syringe Part No.
250 µL	✓	1/4-28 UNF	250D-SPARK-GT	0318348	006683
1 mL	✓	1/4-28 UNF	1MD-SPARK-GT	0318448	008183

Thermo Scientific Instruments

SPECIFICATIONS	
Accuracy and Reproducibility	± 1 % (dispensed volume)
Borosilicate Glass Barrel Outer Diameter (OD)	250 µL = 8 mm
Scale Length	No scale (60mm stroke)
International Standards Traceability	

Syringe Volume	PTFE Tipped Plunger	Front Thread	Syringe Code	Replacement Plunger Part No.	Syringe Part No.
AS100/300 and AS1000/3000/3500					
250 µL	✓	1/4-28 UNF	250C-THERMOSPEC	031833	006660



Waters Instruments

SPECIFICATIONS	
Accuracy and Reproducibility	± 1 % (dispensed volume)
Borosilicate Glass Barrel Outer Diameter (OD)	8 mm
Scale Length	No scale (60 mm stroke)
International Standards Traceability	

Syringe Volume	PTFE Tipped Plunger	Front Thread	Syringe Code	Replacement Plunger Part No.	Syringe Part No.
25 µL	✓	1/4-28 UNF	25D-WISP	031819	003990
250 µL	✓	1/4-28 UNF	250D-WISP	031834	006690

WISP Dipper Needle

Needle Length (mm)	Needle OD (mm)	Needle ID (mm)	Needle Tip	Description	Part No.
121	1.587	0.5	Side Hole Cone	N-121/1.59(0.5)SH	038265





Syringes and Accessories

LC Pump High Capacity Syringes

High capacity Luer Lock syringes are ideal for loop fill injection techniques when used in conjunction with an LC tipped Luer Lock needle. They are also perfect for flushing sample loops after injection, and priming the LC pump.

SPECIFICATIONS	
Accuracy and Reproducibility	± 1 % (dispensed volume)
Borosilicate Glass Barrel Outer Diameter (OD)	1 mL = 9 mm, 2.5 mL = 11 mm, 5 mL = 14 mm, 10 mL = 18 mm, 25 mL = 27 mm
Scale Length	60 mm
International Standards Traceability	



Syringe Volume	PTFE Tipped Plunger	Termination	Syringe Code	Replacement Plunger Part No.	Syringe Part No.
1 mL	✓	Fixed Luer Lock	1MDF-LL-GT	0318441	008025
2.5 mL	✓	Fixed Luer Lock	2.5MDF-LL-GT	031852	008425
5 mL	✓	Fixed Luer Lock	5MDF-LL-GT	0318562	008762
10 mL	✓	Fixed Luer Lock	10MDF-LL-GT	031864	008962
25 mL	✓	Fixed Luer Lock	25MDF-LL-GT	031874	009463



Description	Pack Size	Part No.
Luer Lock Valve Adaptor	2	200010

Expert Tip:

For complete loop fill, the syringe capacity should be greater than twice the loop volume. The loop capacity sets the injection volume. For partial loop fill, the injection volume should be no greater than half the loop capacity. The injection size sets the injection volume.

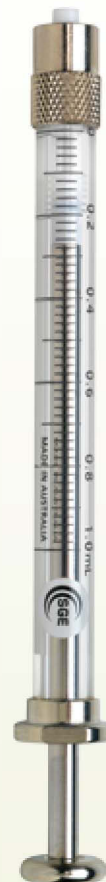



Syringes and Accessories

1 - 100 mL PTFE Tipped Plunger

Suitable for Instrument, Dispenser and Manual Use

SPECIFICATIONS	
Accuracy and Reproducibility	± 1 % (dispensed volume)
Borosilicate Glass Barrel Outer Diameter (OD)	1 mL = 9 mm, 2.5 mL = 11 mm, 5 mL = 14 mm, 10 mL = 18 mm, 25 mL = 27 mm, 50 mL = 32.8 mm, 100 mL = 40.8 mm
Scale Length	1 - 25 mL = 60 mm, 50 mL = 84.2 mm, 100 mL = 104 mm
Thread in Plunger Button	6-32 UNC
International Standards Traceability	



Syringe Volume	PTFE Tipped Plunger	Needle Length (mm)	Needle Gauge	Needle OD (mm)	Needle ID (mm)	Needle Tip	Syringe Code	Replacement Needle Part No.	Replacement Plunger Part No.	Syringe Part No.
Fixed Needle										
1 mL	✓	50	22	0.72	0.37	Bevel	1MDF-GT	-	0318441	008102
2.5 mL	✓	50	22	0.72	0.37	Bevel	2.5MDF-GT	-	031852	008502
Removable Needle										
1 mL	✓	50	23	0.63	0.32	Bevel	1MR-GT	039110	031842	008100*
2.5 mL	✓	50	23	0.63	0.32	Bevel	2.5MDR-GT	039110	031852	008500
5 mL	✓	50	23	0.63	0.32	Bevel	5MDR-GT	031516	031856	008700
10 mL	✓	50	23	0.63	0.32	Bevel	10MDR-GT	031516	031862	008900
Fixed Luer Tip										
1 mL	✓	-	-	-	-	Luer Tip	1MF-LT-GT	-	031842	008020*
2.5 mL	✓	-	-	-	-	Luer Tip	2.5MDF-LT-GT	-	031852	008420
Fixed Luer Lock										
1 mL	✓	-	-	-	-	Luer Lock	1MDF-LL-GT	-	0318441	008025
2.5 mL	✓	-	-	-	-	Luer Lock	2.5MDF-LL-GT	-	031852	008425
5 mL	✓	-	-	-	-	Luer Lock	5MDF-LL-GT	-	0318562	008762
10 mL	✓	-	-	-	-	Luer Lock	10MDF-LL-GT	-	031864	008962
25 mL	✓	-	-	-	-	Luer Lock	25MDF-LL-GT	-	031874	009463
Removable Luer Lock										
5 mL	✓	-	-	-	-	Luer Lock	5MDR-LL-GT	-	031856	008760
10 mL	✓	-	-	-	-	Luer Lock	10MDR-LL-GT	-	031862	008960
25 mL	✓	-	-	-	-	Luer Lock	25MR-LL-GT	-	031870	009462
50 mL	✓	-	-	-	-	Luer Lock	50MR-LL-GT	-	0312170	009660*
100 mL	✓	-	-	-	-	Luer Lock	100MR-LL-GT	-	0312176	009760*

* No thread in plunger stem of syringe part numbers 008100, 008020, 009660 and 009760.



Expert Tip :

The Luer Lock termination provides extra security when using Luer Lock needles and fittings, syringe filters and pump priming.



General - Replacement for Hamilton Pump Syringes

Syringes and
Accessories

SPECIFICATIONS	
Accuracy and Reproducibility	± 1 % (dispensed volume)
Borosilicate Glass Barrel Outer Diameter (OD)	25 µL to 500 µL = 8mm, 1 mL = 9 mm, 2.5 mL = 11 mm, 5 mL = 14 mm, 10 mL = 18 mm, 25 mL = 27 mm
Scale Length	60 mm
Thread in Plunger Button	6-32 UNC
International Standards Traceability	

C and CX Syringes

Syringe Volume	PTFE Tipped Plunger	Termination	Syringe Code	Replacement Plunger Part No.	Syringe Part No.
25 µL	✓	1/4-28 UNF	25D-CX	0318191	003995
50 µL	✓	1/4-28 UNF	50D-CX	0318221	004995
100 µL	✓	1/4-28 UNF	100D-CX	0318271	005990
250 µL	✓	1/4-28 UNF	250D-CX	031833	006995
500 µL	✓	1/4-28 UNF	500D-CX	0318381	007995
1 mL	✓	1/4-28 UNF	1MD-C	0318441	008185
2.5 mL	✓	1/4-28 UNF	2.5MD-C	031854	008687
5 mL	✓	1/4-28 UNF	5MD-C	0318562	008787
10 mL	✓	1/4-28 UNF	10MD-C	031864	008987

LL and LLX Syringes

Syringe Volume	PTFE Tipped Plunger	Termination	Syringe Code	Replacement Plunger Part No.	Syringe Part No.
50 µL	✓	Luer Lock	50F-LLX-GT	0318221	004232
100 µL	✓	Luer Lock	100F-LLX-GT	0318271	005232
250 µL	✓	Luer Lock	250F-LLX-GT	031833	006232
500 µL	✓	Luer Lock	500F-LLX-GT	0318381	007232
1 mL	✓	Luer Lock	1MDF-LL-GT	0318441	008025
2.5 mL	✓	Luer Lock	2.5MDF-LL-GT	031852	008425
5 mL	✓	Luer Lock	5MDF-LL-GT	0318562	008762
10 mL	✓	Luer Lock	10MDF-LL-GT	031864	008962
25 mL	✓	Luer Lock	25MDF-LL-GT	031874	009463

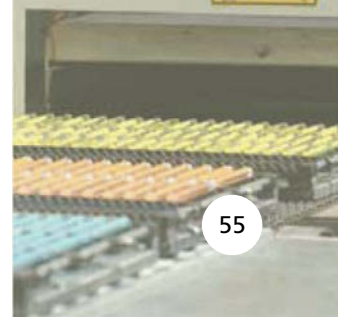

Shimadzu Total Organic Carbon Analyzer – TOC5000

Syringes and
Accessories

SPECIFICATIONS	
Accuracy and Reproducibility	± 1 % (dispensed volume)
Borosilicate Glass Barrel Outer Diameter (OD)	250 µL = 8 mm
Scale Length	60 mm
International Standards Traceability	

Syringe Volume	PTFE Tipped Plunger	Termination	Syringe Code	Replacement Plunger Part No.	Syringe Part No.
250 µL	✓	1/4-28 UNF	250C-SHIM (TOC)	031832	006680

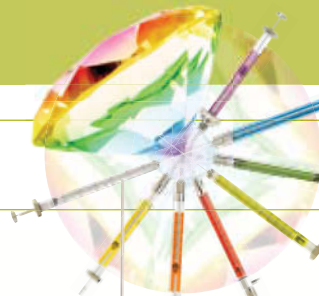

Syringes and Accessories

MEPS™ - Micro Extraction by Packed Sorbent

For more information about MEPS™ - Micro SPE, please refer to pages 222-225.

Choose your MEPS™ syringe

The current range of syringes may be used manually or in autosamplers. To maximize flexibility, MEPS™ syringes are supplied without a needle. MEPS™ BIN (barrel insert needle) options are listed on page 225.

Syringe Volume	PTFE Tipped Plunger	Autosampler	Syringe Scale Length (mm)	Syringe Barrel OD (mm)	Replacement Plunger Part No.	Syringe Part No.
100 µL	✓	Agilent Instrument 7693A	54.1	6.5	0318263	005292
100 µL	✓	CTC Analytics, HTA 300APlus, Thermo Scientific and Varian 8400 systems	60	6.7	031826	005291
250 µL	✓	Agilent Instruments 7693A	54.1	6.5	0318303	006293
250 µL	✓	HTA 300APlus, Thermo Scientific and Varian 8400 systems	60	6.7	031831	006291
250 µL	✓	CTC Analytics systems	60	7.8	0318301	006292

MEPS™ XCHANGE® Syringes

For use on CTC PAL-xt

Syringe Volume	PTFE Tipped Plunger	Autosampler	Syringe Barrel OD (mm)	Replacement Plunger Part No.	Syringe Part No.
100 µL	✓	CTC PAL-xt	6.7	2930580	2928500
250 µL	✓	CTC PAL-xt	6.7	2930680	2928600

eVol® MEPS™

eVol® is ideal for use with MEPS™. The eVol® custom programming function allows manual MEPS™ to be automated - the sampling, processing, extraction and injection steps are performed using the same syringe.

Refer to pages 21-24 for more information about eVol®.

Syringe Volume	PTFE Tipped Plunger	Description	Replacement Plunger Part No.	Syringe Part No.
50 µL	✓	eVol® XCHANGE™ Syringe for MEPS™	2910382	2910027
100 µL	✓	eVol® XCHANGE™ Syringe for MEPS™	2910383	2910028
500 µL	✓	eVol® XCHANGE™ Syringe for MEPS™	2910384	2910026

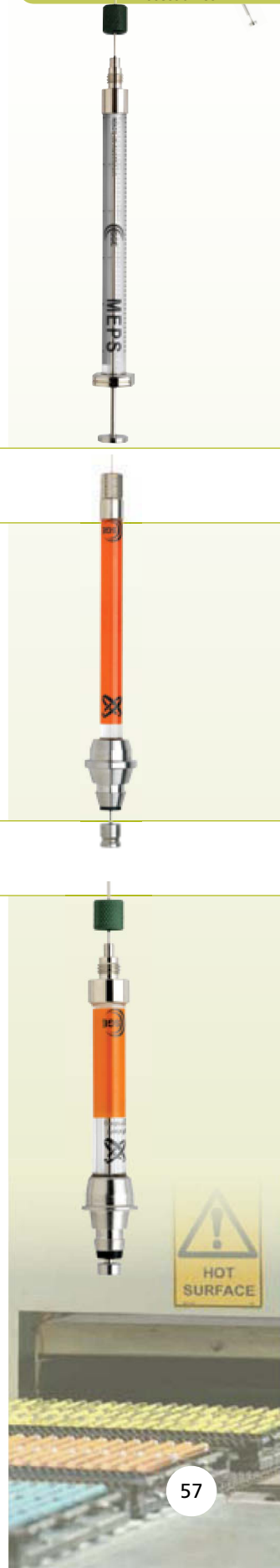

GC On-Column

Syringes and
Accessories

SPECIFICATIONS	
Accuracy and Reproducibility	0.5 μL = $\pm 2\%$, 5 μL and 10 μL = $\pm 1\%$ (dispensed volume)
Borosilicate Glass Barrel Outer Diameter (OD)	0.5 μL = 8 mm, 5 μL and 10 μL = 6.5 mm
Scale Length	0.5 μL = 63.7 mm, 5 μL and 10 μL = 54.1 mm
International Standards Traceability	

A range of popular on-column syringes are available for general purpose applications. An extended range of instrument specific syringes is also available for most common on-column inlets.

When selecting an on-column syringe, the needle Outside Diameter (OD) must be smaller than the Inside Diameter (ID) of the GC capillary column. Care must also be taken to select the correct needle length to suit the on-column injector. Wherever possible, a sheathed needle should be used for maximum needle strength and protection.

Types of needles offered:

- All fused silica or all stainless steel.
- Sheathed fused silica or sheathed stainless steel.

Fused silica needles are coated with polyimide and should not be operated above 360 °C.

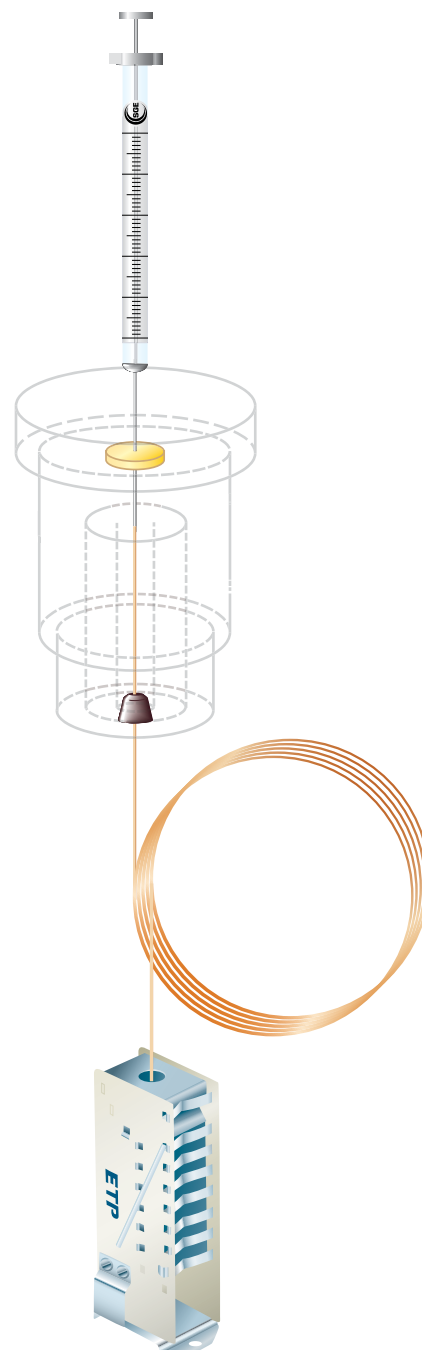

General GC On-Column Syringes

Syringe Volume	Needle Length (mm)	Needle Gauge	Needle OD (mm)	Needle ID (mm)	Needle Material	Syringe Code	Replacement Needle Part No.	Syringe Part No.
0.5 µL	100	-	0.23	0.1	Sheathed Stainless Steel	0.5BR-OC-100S	033610*	000372
0.5 µL	70	26	0.47	0.1	Stainless Steel	0.5BR-OC-7/0.47	033630*	000376
0.5 µL	75	-	0.23	0.1	Stainless Steel	0.5BR-OC-CE-7.5	033620*	000380
5 µL	100	-	0.17	0.1	Silica	5R-OC-100VS	036610	001552
5 µL	100	-	0.17	0.1	Sheathed Silica	5R-OC-100SVS	036635	001554
10 µL	100	-	0.17	0.1	Silica	10R-OC-100VS	037610	002520

* Plunger and needle replacement kits.

Instrument Specific GC On-Column Syringes

Syringe Volume	PTFE Tipped Plunger	Needle Length (mm)	Needle OD (mm)	Needle ID (mm)	Needle Material	Syringe Code	Replacement Needle Part No.	Replacement Plunger Part No.	Syringe Part No.
Agilent Instruments									
5 µL	-	50	0.19	0.11	Stainless Steel	5R-OC-5/0.19	036701	-	001585
5 µL	-	50	0.23	0.11	Stainless Steel	5R-OC-5/0.23	036703	-	001587
PerkinElmer Instruments									
5 µL	-	100	0.17	0.1	Silica	5R-OC-100VS	036610	-	001552
Carlo Erba									
0.5 µL	-	75	0.23	0.1	Stainless Steel	0.5BR-OC-CE-7.5	033620*	-	000380
5 µL	-	75	0.23	0.11	Stainless Steel	5R-OC-CE	036675	-	001560
10 µL	✓	75	0.23	0.11	Stainless Steel	10R-GT-OC-CE	037675	031811	002500
Shimadzu Instruments									
5 µL	-	50	0.19	0.11	Stainless Steel	5R-OC-5/0.19	036701	-	001585
5 µL	-	50	0.23	0.11	Stainless Steel	5R-OC-5/0.23	036703	-	001587

* Plunger and needle replacement kits.

Expert Tip :

Please note the GC On-Column Syringes are manual syringes with needle specifications to suit specific instruments. They are not for use with autosamplers.



See page 200 for Retention Gap Kits that enable GC on-column injection into a wide bore (0.53 mm ID) using 0.47 mm OD needle syringes.



0.5 L to 2 L Jumbo

Syringes and Accessories



SPECIFICATIONS	
Accuracy and Reproducibility	± 2 % (dispensed volume)
Acrylic Barrel Outer Diameter (OD)	0.5 L = 70 mm, 1 L = 100 mm and 2 L = 130 mm
Scale Length	0.5 L = 179.2 mm, 1 L = 159.1 mm and 2 L = 179 mm
International Standards Traceability	

- Designed for holding and dispensing large volumes of gas.
- Heavy duty acrylic barrels.
- Easy access to sample for the addition of standards or removal of subsample via secondary port.
- Plunger stem is removable for ease of transportation and storage.
- Ideal for calibration of medical equipment such as respirators and spirometers, and for stack and air sampling.
- Compatible with a range of fittings; has a 7/16" UNEF thread and designed to be used with Luer Lock fittings and needles. For the range of SGE Luer Lock needles refer to page 67.
- Refer to pages 40 to 42 for the range of valves suitable for use with these syringes.

Syringe Volume	Barrel Length (mm)	Barrel OD (mm)	Major Scale Divisions (mL)	Minor Scale Divisions (mL)	Syringe Code	Replacement Plunger O-ring Part No.	Syringe Part No.
0.5 L	245	70	50	25	500MAR-LL-GT	032527	009910
1 L	245	100	100	50	1000MAR-LL-GT	032532	009920
2 L	245	130	200	100	2000MAR-LL-GT	032537	009930

Jumbo Syringe Accessories

Description	Part No.
Luer Lock Adaptor	031902
Sealing CS Septa (packet of 50)	041822
MSV Syringe Valve Connector	030930
I flow Two Port Standard Valve*	030200

*Other valve configurations available, see pages 40 to 42.

Gas Sealing Gland

SPECIFICATIONS	
Accuracy and Reproducibility	± 1 % (dispensed volume)
Borosilicate Glass Barrel Outer Diameter (OD)	8 mm
Scale Length	60 mm
International Standards Traceability	

- A gas sealing gland (a gas tight, high pressure PTFE seal) is used at the plunger end of the syringe barrel.
- Ideal for applications requiring high or low temperature function.
- These syringes are designed to avoid cold flow deformation and leakage sometimes associated with PTFE tipped plungers in low temperature applications.
- Plungers are not interchangeable.

Syringe Volume	Needle Length (mm)	Needle Gauge	Needle OD (mm)	Needle ID (mm)	Needle Tip	Syringe Code	Replacement Needle Part No.	Syringe Part No.
Fixed Needle								
25 µL	50	25	0.5	0.2	Bevel	25F-GSG	-	003600
50 µL	50	25	0.5	0.2	Bevel	50F-GSG	-	004600
100 µL	50	25	0.5	0.2	Bevel	100F-GSG	-	005600
250 µL	50	25	0.5	0.2	Bevel	250F-GSG	-	006600
500 µL	50	25	0.5	0.2	Bevel	500F-GSG	-	007600
Removable Needle								
25 µL	50	25	0.5	0.2	Bevel	25R-GSG	038110	003610
50 µL	50	25	0.5	0.2	Bevel	50R-GSG	038110	004610
100 µL	50	25	0.5	0.2	Bevel	100R-GSG	038110	005610
250 µL	50	25	0.5	0.2	Bevel	250R-GSG	038110	006610
500 µL	50	25	0.5	0.2	Bevel	500R-GSG	038110	007610

Syringes and Accessories



Syringes and Accessories



Headspace/Soil Gas

SPECIFICATIONS	
Accuracy and Reproducibility	± 1 % (dispensed volume)
Borosilicate Glass Barrel Outer Diameter (OD)	5 mL = 14 mm and 10 mL = 18mm
Scale Length	60 mm
International Standards Traceability	

Syringe Volume	Probe Length (mm)	Needle Gauge	Probe OD (mm)	Probe ID (mm)	Needle Tip	Syringe Code	Spare Probes Pkt 1	Spare Needles Pkt 5	Replacement Plunger Part No.	Syringe Part No.
5 mL	60	-	1.587	0.75	-	5MDR-HSV	031571	039802	031856	008775*
10 mL	60	-	1.587	0.75	-	10MDR-HSV	031571	039802	031862	008975*
Replacement Probes										
-	60	-	1.587	0.75	Side Hole	-	-	-	-	031571
Replacement Needles										
-	50	23	0.63	0.32	Bevel	-	-	-	-	039802

* Syringe supplied with probe and needle.



High Pressure

SPECIFICATIONS	
Accuracy and Reproducibility	± 1 % (dispensed volume)
Borosilicate Glass Barrel Outer Diameter (OD)	9 mm
Scale Length	60 mm
International Standards Traceability	

- Fitted with a gas tight ON/OFF valve.
- Designed for high pressure gas sampling – rated to 500 psi/3450 kPa.

Syringe Volume	Needle Length (mm)	Needle Gauge	Needle OD (mm)	Needle ID (mm)	Needle Tip	Syringe Code	Replacement Needle Part No.	Syringe Part No.
1 mL	70	23	0.63	0.37	Bevel	1M-BP	0315720	008170
1 mL	70	23	0.63	0.36	Side Hole	1M-BP (0.36)H	0315722	008171





Repeating Adaptor (RAX)

The SGE Repeating Adaptor (RAX) ensures reproducibility of sample volumes with repeatedly accurate and precise injections.

The RAX is suitable for use on syringes with capacities from 0.5 µL through to 500 µL. It has easy to use finger grips and can be set to any desired volume. The RAX can be used as added protection against both plunger

blowout at elevated pressures and plunger bending. The flat sides allow it to sit securely on the bench with the needle in a raised position helping to prevent damage. The RAX is supplied with an innovative double-ended tool to facilitate assembly. It is easily and quickly installed, and if required, removed, replaced and even swapped between syringes.

Description	Part No.
Repeating Adaptor RAX	031930



Syringe Racks

Syringe racks organize your syringes and ensure that they do not roll off the bench or top of the instrument and break. A must for every laboratory.

Description	Part No.
Syringe rack holds 6 syringes	031776
Syringe rack holds 6 XCHANGE® syringes	031786



Needle Cleaning Kit

Syringes and Accessories

Everything needed for thorough needle cleaning. A range of stylet wires, tweezers for holding the wires and a non-ionic surfactant material are provided in a convenient package.



Description	Part No.
Needle Cleaning Kit	031782
Kit contains:	
Tube of Stylet Wires 150 mm x 0.10 mm OD	
Tube of Stylet Wires 150 mm x 0.15 mm OD	
Tube of Stylet Wires 150 mm x 0.20 mm OD	
20 mL Cleaning Solution Concentrate	
Tweezers	

Stylet Wires

Stylet wires are used for cleaning the inside of needles and are available in 3 sizes – check the needle internal diameter of the syringe

to select the suitable wires (the needle ID is listed for syringes throughout this selection guide).

Description	Pack Size	Part No.
Stylet Wires 150 mm x 0.10 mm OD	5	031745
Stylet Wires 150 mm x 0.15 mm OD	5	031746
Stylet Wires 150 mm x 0.20 mm OD	5	031747



Syringes and Accessories

NanoVolume Syringe Plunger and Needle Kits

Kits are available for 500 – 5000 nL (0.5 µL – 5.0 µL) NanoVolume syringes. The kits are supplied with a matched plunger and needle, both must be replaced together. A list of replacement kits is below. Find the SGE syringe part number to determine the appropriate replacement plunger and needle kit.

Needle Length (mm)	Needle Gauge	Needle OD (mm)	Needle ID (mm)	Needle Tip	Description	Syringe Part No.	Replacement Plunger/ Needle Kit Part No.
0.5 µL Syringes, 6.5 mm OD Barrel							
50	23	0.63	0.155	Cone	NP0.5BN-5/0.63C	000300	033010
50	23	0.63	0.155	Bevel	NP0.5BN-5/0.63BV	000301	033011
50	26	0.47	0.155	Cone	NP0.5BN-5/0.47C	000303	033012
0.5 µL Syringes, 8mm OD Barrel							
70	23	0.63	0.1	Cone	NP0.5B-7C	000310	033057
70	23	0.63	0.1	Bevel	NP0.5B-7BV	000311	033060
100	-	0.23	0.1	Cone	NP0.5B-OC-10/0.23	-	033605
100	-	0.23	0.1	Cone	NP0.5B-OC-10/0.23T (Sheathed)	000372	033610
75	26	0.23	0.1	Cone	NP0.5B-OC-7.5/0.23	000380	033620
70	26	0.47	0.1	Cone	NP0.5B-OC-7/0.47	000376	033630
1 µL Syringes, 8 mm OD Barrel							
50	23	0.63	0.155	Cone	NP1B-5C	000500	034055
50	23	0.63	0.155	Bevel	NP1B-5BV	000501	034056
70	23	0.63	0.155	Cone	NP1B-7C	000505	034057
115	23	0.63	0.155	Cone	NP1B-11.5C	000510	034059
70	23	0.63	0.155	Bevel	NP1B-7BV	000506	034060
70	26	0.47	0.155	Cone	NP1B-OC-7/0.47	000570	034610
5 µL Syringes, 8 mm OD Barrel							
50	23	0.63	0.365	Cone	NP5B-5C	000800	035055
50	23	0.63	0.365	Bevel	NP5B-5BV	000801	035056
70	23	0.63	0.365	Cone	NP5B-7C	000802	035057
70	23	0.63	0.365	Bevel	NP5B-7BV	000803	035058
115	23	0.63	0.365	Cone	NP5B-11.5C	000804	035059

Expert Tip :

When replacing the plunger and needle follow the instructions included in the kit – the front cover nut must be loosened before removing the plunger.



Autosampler NanoVolume Syringe Plunger and Needle Kits

Syringe Volume	Needle Length (mm)	Needle Gauge	Needle OD (mm)	Needle ID (mm)	Needle Tip	Description	Syringe Part No.	Replacement Plunger/ Needle Kit Part No.
Agilent 7673, 7683 and 6850 ALS Syringes								
0.5 µL	42	26	0.47	0.155	Cone	NP0.5B-AG-0.47	000400	033708
0.5 µL	42	23	0.63	0.155	Cone	NP0.5B-AG-0.63	000410	033715
0.5 µL	42	23/26	0.63/0.47	0.155	Cone	NP0.5B-AG-0.63/0.47	000415	033730
1 µL	42	23	0.63	0.22	Cone	NP1B-AG-0.63	000610	034715
CTC/Leap and Thermo Scientific								
0.5 µL	50	26	0.47	0.155	Cone	NP0.5BN-C/T-0.47C	000490	033770
0.5 µL	50	23	0.63	0.155	Cone	NP0.5BN-C/T-0.63C	000492	033772
2 µL	50	26	0.47	0.22	Cone	2BR-C/T-5/0.47C	000790	034905
PerkinElmer - AutoSystem and Clarus 500								
0.5 µL	70	26	0.47	0.155	Cone/Bevel	NP0.5B-PE-0.47	000475	033750
0.5 µL	70	23	0.63	0.155	Cone	NP0.5B-PE-0.63	000478	033765
Shimadzu - AOC 14, 17, 20 and 20i								
0.5 µL	42	26	0.47	0.155	Cone	NP0.5B-S-0.47	000440	033738
0.5 µL	42	23	0.63	0.155	Cone	NP0.5B-S-0.63	000445	033745
Varian 8035, 8100 and 8200								
1 µL	51	26	0.47	0.155	Cone	NP1B-VA8X	000655	034720



Needles

A variety of replacement needles are available for each syringe capacity. The needle length, gauge and tip style can be changed to optimize the syringe for a wide range of applications. For tips on needle selection refer to pages 27-28.

Syringes and
Accessories

For needles for
5 μ L eVol® syringes
refer to page 24.



Needle Length (mm)	Gauge	Needle OD (mm)	Needle ID (mm)	Tip Style	Needle Code	Pack Size	Part No.
5 μL Syringe							
42	26	0.47	0.11	Cone	N5-AG-0.47	2	036710
42	23/26	0.63/0.47	0.11	Cone	N5-AG-0.63/0.47	2	036730
42	23	0.63	0.11	Cone	N5-AG-0.63	2	036720
50	-	0.17	0.1	On-Column	N5-OC-5/0.17VS	2	036603
50	-	0.19	0.1	On-Column	N5-AG-OC-0.19	2	036701
50	-	0.23	0.11	On-Column	N5-AG-OC-0.23	2	036703
50	26	0.47	0.11	Bevel	N5-5	5	036110
50	26	0.47	0.11	Cone	N5-5C	2	036010
50	26	0.47	0.11	Dome	N5-5D	2	036510
50	26	0.47	0.11	Sheathed/Bevel	N5-5T	2	036310
50	26	0.47	0.11	Side Hole/Dome	N5-5H	2	036410
50	23	0.63	0.11	Cone	N5-5/0.63C	2	036011
51 (2")	22	0.028"	0.17	LC	N5-LC	5	036250
70	26	0.47	0.11	Bevel	N5-7	5	036130
70	26	0.47	0.11	Cone	N5-7C	2	036030
70	26	0.47	0.11	Dome	N5-7D	2	036530
70	23	0.63	0.11	Cone	N5-7-0.63C	2	036031
75	-	0.17	0.1	On-Column	N5-OC-7.5/0.17VS	2	036605
75	-	0.23	0.1	On-Column	N5-OC-7.5/0.23	2	036675
95	-	0.27	0.11	On-Column	N5-OC-9.5/0.27 SSS	2	036685
100	-	0.17	0.1	On-Column	N5-OC-10/0.17VS	2	036610
100	-	0.17	0.1	On-Column	N5-OC-10/0.17SVS	2	036635
107	-	0.19	0.1	On-Column	N5-OC-10.7/0.19S	2	036651
110	-	0.17	0.1	On-Column	N5-OC-11/0.17VS	2	036625
115	26	0.47	0.11	Bevel	N5-11.5	5	036160
115	26	0.47	0.11	Cone	N5-11.5C	2	036060
10 μL Syringe							
42	26	0.47	0.11	Cone	N10-AG-0.47	2	037715
42	26	0.47	0.11	Cone	N10-S-0.47	2	037745
42	23/26	0.63/0.47	0.11	Cone	N10-AG-0.63/0.47	2	037730
42	23	0.63	0.11	Cone	N10-AG-0.63	2	037717
42	23	0.63	0.11	Cone	N10-S-0.63	2	037747
50	26	0.47	0.11	Bevel	N10-5	5	037110
50	26	0.47	0.11	Cone	N10-5C	2	037010
50	26	0.47	0.11	Dome	N10-5D	2	037510
50	26	0.47	0.11	Sheathed/Bevel	N10-5T	2	037310
50	26	0.47	0.11	Side Hole/Dome	N10-5H	2	037410
50	25	0.5	0.11	Bevel	N10-VA8035-II	2	037776
50	25	0.5	0.12	LC	N10-WLC	5	037260
50	25	0.5	0.2	Side Hole/Dome	N10-VA800H-II	1	037780
50	23	0.63	0.11	Bevel	N10-5/0.63	5	037111
50	23	0.63	0.11	Cone	N10-5/0.63C	2	037011
50	23	0.63	0.11	Cone	N10-C/T-5/0.63C	2	037787
51 (2")	22	0.028"	0.17	LC	N10-LC	5	037250
53	25	0.5	0.11	Side Hole/Dome	N10-VA8X00H-II	1	037777
53	23	0.63	0.11	Side Hole/Cone	N10-VA8X00H-0.63-II	2	037779
56	23	0.63	0.11	Cone	N10-5.6/0.63C	2	037021
56	22	0.028"	0.17	LC	N10-5.6/22LC	5	037221
70	26	0.47	0.11	Bevel	N10-7	5	037130
70	26	0.47	0.11	Cone	N10-7C	2	037030
70	26	0.47	0.11	Sheathed/Bevel	N10-7T	2	037330
70	23	0.63	0.11	Cone	N10-7/0.63C	2	037031
70	22	0.028"	0.17	LC	N10-LC-7	5	037270
75	-	0.17	0.1	On-Column	N10-OC-7.5/0.17VS	2	037605
75	-	0.23	0.1	On-Column	N10-OC-7.5/0.23	2	037675
75	26	0.47	0.11	Dome	N10-7.5D	2	037540
100	-	0.17	0.1	On-Column	N10-OC-10/0.17VS	2	037610
105	-	0.17	0.11	On-Column	N10-VA8035-0.17-II	2	037778
115	26	0.47	0.11	Bevel	N10-11.5	5	037160
115	26	0.47	0.11	Cone	N10-11.5C	2	037060

Needle Length (mm)	Gauge	Needle OD (mm)	Needle ID (mm)	Tip Style	Needle Code	Pack Size	Part No.
25 - 500 µL Syringe and 50 µL eVol® Syringe							
42	23	0.63	0.24	Cone	N25/500-AG-0.63	2	038717
50	26	0.47	0.2	Cone	N25/500-C/T-5/0.47C	2	038732
50	25	0.5	0.2	Bevel	N25/500-5	5	038110
50	25	0.5	0.2	Cone	N25/500-5C	2	038010
50	25	0.5	0.2	Dome	N25/500-5D	2	038510
50	25	0.5	0.2	LC	N25/500-WLC	5	038260
50	25	0.5	0.2	Side Hole/Dome	N25/500-5H	2	038410
50	25	0.5	0.2	PTFE Coated	N25/500-5P	2	038910
50	23	0.63	0.15	Bevel	N25/500-C/T-5/0.63	5	038730
50	23	0.63	0.15	Cone	N25/500-C/T-5/0.63C	2	038735
50	23	0.63	0.24	Bevel	N25/500-5/0.63	5	038111
50	25	0.5	0.2	Sheathed/Bevel	N25/500-5T	2	038310
51 (2")	22	0.028"	0.37	LC	N25/500-LC	5	038250
53	25	0.5	0.15	Side Hole/Dome	N25/500-VAR-5.3/0.5H	1	038745
56	23	0.63	0.15	Cone	N25/500-5.6/0.63C	2	038737
56	22	0.028"	0.17	LC	N25/500-5.6/22(0.17)LC	5	038259
56	22	0.028"	0.37	LC	N25/500-5.6/22(0.375)LC	5	038255
70	25	0.5	0.2	Bevel	N25/500-7	5	038130
70	25	0.5	0.2	Cone	N25/500-7C	2	038030
70	25	0.5	0.2	Dome	N25/500-7D	2	038530
70	25	0.5	0.2	Side Hole/Dome	N25/500-7H	2	038430
70	23	0.63	0.24	Bevel	N25/500-7/0.63	5	038131
70	22	0.028"	0.37	LC	N25/500-LC-7	5	038270
80	25	0.5	0.2	Cone	N25/500-C/T-8/0.5C	3	031536
115	25	0.5	0.2	Bevel	N25/500-11.5	5	038160
115	25	0.5	0.2	Cone	N25/500-11.5C	2	038060
115	25	0.5	0.2	Side Hole/Dome	N25/500-11.5H	2	038460
115	23	0.63	0.24	Bevel	N25/500-11.5/0.63	5	038161
180	23	0.63	0.24	Bevel	N25/500-NMR-18/0.63BV	2	038138
1 - 2.5 mL Syringe and 500 µL eVol® Syringe							
50	25	0.5	0.2	LC	NM1/2.5-WLC	5	039260
50	23	0.63	0.32	Bevel	NM1/2.5-5	5	039110
50	23	0.63	0.32	Dome	NM1/2.5-5/0.63D	2	039116
50	23	0.63	0.32	Side Hole/Dome	NM1/2.5-5/0.63H	2	039120
50	22	0.028"	0.37	Bevel	NM1/2.5-5/22BV	5	039115
51 (2")	22	0.028"	0.37	LC	NM1/2.5-LC	5	039250
56	23	0.63	0.32	Bevel	NM1/2.5-5.6/0.63BV	5	039125
56	22	0.028"	0.375	LC	NM1/2.5-5.6/22LC	5	039256
70	23	0.63	0.32	Bevel	NM1/2.5-7	5	039130
115	23	0.63	0.32	Bevel	NM1/2.5-11.5	5	039160
180	23	0.63	0.32	Bevel	NM1/2.5-NMR-18/0.63BV	2	039138
5-10 mL Syringe							
50	24	0.5	0.2	LC	NM5/10-WLC	5	0315234
50	23	0.63	0.32	Bevel	NM5/10-5	2	031516
51 (2")	22	0.028"	0.37	LC	NM5/10-LC	5	0315233
70	23	0.63	0.32	Bevel	NM5/10-7	5	031521
Luer Lock Needles							
50	25	0.5	0.2	LC	NLL-WLC	2	039897
50	23	0.63	0.32	Bevel	NLL-5/23	5	039802
50	23	0.63	0.32	Side Hole/Dome	NLL-5/23H	2	039803
50	19	1.07	0.65	Bevel	NLL-5/19	5	039822
50	19	1.07	0.65	Side Hole/Dome	NLL-5/19H	2	039823
50	18	1.27	0.8	Bevel	NLL-5/18	5	039842
50	16	1.57	1.1	Bevel	NLL-5/16	5	039862
50	14	2.1	1.6	Bevel	NLL-5/14	5	039880
51 (2")	22	0.028"	0.37	LC	NLL-LC	2	039895
70	23	0.63	0.32	Bevel	NLL-7/23	5	039807
70	23	0.63	0.32	Side Hole/Dome	NLL-7/23H	2	039808
70	19	1.07	0.65	Bevel	NLL-7/19	5	039827
70	18	1.27	0.8	Bevel	NLL-7/18	5	039847
70	16	1.57	1.1	Bevel	NLL-7/16	5	039867
115	23	0.63	0.32	Bevel	NLL-11.5/23	5	039811
115	19	1.07	0.65	Bevel	NLL-11.5/19	5	039831
115	18	1.27	0.8	Bevel	NLL-11.5/18	5	039851
115	16	1.57	1.1	Bevel	NLL-11.5/16	5	039871
115	14	2.1	1.6	Bevel	NLL-11.5/14	5	039891

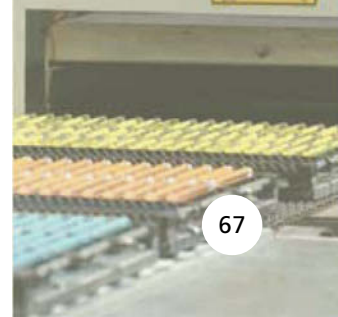

Syringe Components

Syringes and
Accessories

Description	Pack Size	Part No.
Replacement Luer Lock Fitting (includes Kel-F® Luer Cone and threaded Metal Adaptor)	1	031902
Replacement Kel-F® Luer Cones	2	031903
Replacement PTFE Plunger Seal (supplied with tool) for 0.5 µL NanoVolume syringes with 8 mm OD Barrels	1	032002
Replacement PTFE Plunger Seal (supplied with tool) for 0.5 µL NanoVolume syringes with 6.5 mm OD Barrels and 1 µL NanoVolume syringes	1	032004
Replacement PTFE Plunger Seal (supplied with tool) for 5 µL NanoVolume syringes	1	032006

Plungers Listed by Syringe Part Number

Replacement Plunger Part No.	Plunger Code	Pack Size	Syringe Part No.
031807	P5F-PE-GT 5 µL	2	001955
031807	P5F-PE-GT 5 µL	2	001957
031810	P10F-GT 10 µL	2	002200
031810	P10F-GT 10 µL	2	002208
031811	P10R-GT 10 µL	2	002250
031811	P10R-GT 10 µL	2	002313
031810	P10F-GT 10 µL	2	002335
031805	P10-GP-GT 10 µL	2	002455
031811	P10R-GT 10 µL	2	002500
031803	P10F-C/T-GT	1	002715
031808	P10F-AG-GT 10 µL	2	002812
031809	P10R-AG-GT 10 µL	2	002817
031809	P10R-AG-GT 10 µL	2	002818
031808	P10F-AG-GT 10 µL	2	002826
031809	P10R-AG-GT 10 µL	2	002829
031798	P10R-S-GT	2	002902
031218	10A-VP 10 µL	1	002923
031218	10A-VP 10 µL	1	002924
0318121	P10R-C/T-GT	1	002965
0318120	P10F-C/T-GT	1	002977
0318121	P10R-C/T-GT 10 µL	2	002985
0318120	P10F-C/T-GT 10 µL	2	002987
0318120	P10F-C/T-GT 10 µL	2	002991
031815	P25-GT 25 µL	1	003200
031815	P25-GT 25 µL	1	003250
031815	P25-GT 25 µL	1	003312
0318922	P25F-CTC-GT	1	003700
0318922	P25F-CTC-GT	1	003715
031816	P25R-C/T-GT 25 µL	1	003985
031817	P25F-C/T-GT 25 µL	1	003987

Replacement Plunger Part No.	Plunger Code	Pack Size	Syringe Part No.
031816	P25R-C/T-GT	1	003989
031835	P500-GT 500 µL	1	007200
031835	P500-GT 500 µL	1	007229
031835	P500-GT 500 µL	1	007230
0318381	P500D-CX 500 µL	1	007232
031835	P500-GT 500 µL	1	007250
031835	P500-GT 500 µL	1	007279
031835	P500-GT 500 µL	1	007312
031835	P500-GT 500 µL	1	007630
031837	P500-HITACHI 500 µL	1	007660
0318928	P500F-CTC-GT	1	007700
0318928	P500F-CTC-GT	1	007720
0318381	P500D-CX 500 µL	1	007995
031842	P1M-GT 1 mL	1	008020
0318441	P1MD-C-GT 1 mL	1	008025
031842	P1M-GT 1 mL	1	008100
0318441	P1MD-C-GT 1 mL	1	008102
031842	P1M-GT 1 mL	1	008110
0318444	P1MD-CTC-GT 1 mL	1	008120
0318441	P1MD-C-GT	1	008130
0318441	P1MD-C-GT	1	008135
031842	P1M-GT 1 mL	1	008160
0318448	P1MD-SPARK-GT 1 mL	1	008183
0318441	P1MD-C-GT 1 mL	1	008185
031842	P1M-GT 1 mL	1	008195
031842	P1M-GT 1 mL	1	008199
031852	P2.5MD-GT 2.5 mL	1	008420
031852	P2.5MD-GT 2.5 mL	1	008425
031852	P2.5MD-GT 2.5 mL	1	008500
031852	P2.5MD-GT 2.5 mL	1	008502

Replacement Plunger Part No.	Plunger Code	Pack Size	Syringe Part No.
031816	P25R-C/T-GT 25 µL	1	003988
031819	P25-WISP-GT 25 µL	1	003990
0318191	P25D-CX 25 µL	1	003995
031820	P50-GT 50 µL	1	004200
031820	P50-GT 50 µL	1	004229
031820	P50-GT 50 µL	1	004230
0318221	P50D-CX 50 µL	1	004232
031820	P50-GT 50 µL	1	004250
031820	P50-GT 50 µL	1	004279
031820	P50-GT 50 µL	1	004312
031142	P50F-AG-GT	1	004668
031820	P50-GT 50 µL	1	004250
031820	P50-GT 50 µL	1	004279
031820	P50-GT 50 µL	1	004312
031142	P50F-AG-GT	1	004668
031821	P50F-C/T-GT 50 µL	1	004810
0318221	P50D-CX 50 µL	1	004995
031825	P100-GT 100 µL	1	005200
031825	P100-GT 100 µL	1	005229
031825	P100-GT 100 µL	1	005230
0318271	P100D-CX 100 µL	1	005232
031825	P100-GT 100 µL	1	005236
031825	P100-GT 100 µL	1	005250
031825	P100-GT 100 µL	1	005279
031826	P100R-C/T-GT	1	005291
0318263	P100R-AGILENT MEPS™ GT	1	005292
031825	P100-GT 100 µL	1	005312
031826	P100R-C/T-GT 100 µL	1	005330
0318261	P100F-C/T-GT 100 µL	1	005331
031826	P100R-C/T-GT 100 µL	1	005333
0318261	P100F-C/T-GT 100 µL	1	005335
031826	P100R-C/T-GT	1	005337
031823	P100-AG-GT 100 µL	1	005668
0318261	P100F-C/T-GT 100 µL	1	005700
0318261	P100F-C/T-GT	1	005715
0318261	P100F-C/T-GT 100 µL	1	005720
031824	P100-VA8X 100 µL	1	005921
0318271	P100D-CX 100 µL	1	005990
031830	P250-GT 250 µL	1	006200
031830	P250-GT 250 µL	1	006229
031830	P250-GT 250 µL	1	006230
031830	P250-GT 250 µL	1	006250
031831	P250R-C/T-GT	1	006291
031833	P250-THERMO 250 µL	1	006232
0318301	P250R-CTC-GT	1	006292
0318303	P250R-AGILENT-MEPS-GT	1	006293
031830	P250-GT 250 µL	1	006279
031830	P250-GT 250 µL	1	006312
031831	P250R-C/T-GT 250 µL	1	006330
031831	P250R-C/T-GT 250 µL	1	006332
031833	P250-THERMO 250 µL	1	006660
031832	P250-SHIM (TOC)	1	006680
031828	P250-S-GT 250 µL	1	006682
0318348	P250D-SPARK 250 µL	1	006683
031834	P250-WISP-GT 250 µL	1	006690

Replacement Plunger Part No.	Plunger Code	Pack Size	Syringe Part No.
0318926	P250F-CTC-GT	1	006700
0318926	P250F-CTC-GT	1	006720
031833	P250-THERMO 250 µL	1	006995
031852	P2.5MD-GT 2.5 mL	1	008505
031852	P2.5MD-GT 2.5 mL	1	008510
031852	P2.5MD-GT 2.5 mL	1	008560
0318454	P2.5MD-CTC-GT	1	008620
0318451	P2.5MDF-GT	1	008630
0318451	P2.5MDF-GT	1	008635
031854	P2.5MD-C/SHIM(TOC)	1	008687
031856	P5MD-GT 5 mL	1	008700
031856	P5MD-GT 5 mL	1	008760
0318562	P5MDF-GT 5 mL	1	008762
031856	P5MD-GT 5 mL	1	008770
031856	P5MD-GT 5 mL	1	008775
0318562	P5MDF-GT 5 mL	1	008787
031856	P5MD-GT 5 mL	1	008820
031862	P10MD-GT 10 mL	1	008900
031862	P10MD-GT 10 mL	1	008960
031864	P10MDF-LL 10 mL	1	008962
031862	P10MD-GT 10 mL	1	008970
031862	P10MD-GT 10 mL	1	008975
031864	P10MDF-LL 10 mL	1	008987
031870	P25MD-GT 25 mL	1	009462
031870	P25MD-GT 25 mL	1	009472
0312170	50MAX-P 50 mL	1	009660
0312170	50MAX-P 50 mL	1	009670
0312176	100MAX-P 100 mL	1	009760
0312176	100MAX-P 100 mL	1	009770
0312170	50MAX-P 50 mL	1	009660
0312170	50MAX-P 50 mL	1	009670
0312176	100MAX-P 100 mL	1	009760
0312176	100MAX-P 100 mL	1	009770
2910380	P5-EVOL	1	2910020
2910380	P5-EVOL	1	2910021
2910382	P-50-EVOL®	1	2910022
2910382	P-50-EVOL®	1	2910023
2910384	P-500-EVOL	1	2910024
2910384	P-500-EVOL	1	2910025
2910382	P-50-EVOL	1	2910027
2930380	P25-XCHANGE®	1	2928310
2910384	P-500-EVOL	1	2910026
2930480	P50-XCHANGE®	1	2928410
2930580	P100-XCHANGE	1	2928510
2930580	P100-XCHANGE	1	2928530
2930680	P250-XCHANGE	1	2928610
2930680	P250-XCHANGE	1	2928630
2930780	P500-XCHANGE	1	2928710
2930780	P500-XCHANGE	1	2928730
2930880	P1M-XCHANGE	1	2928820
2930880	P1M-XCHANGE	1	2928830
2930980	P2.5M-XCHANGE®	1	2928920
2930985	P5M-XCHANGE	1	2928922
2930980	P2.5M-XCHANGE	1	2928930
2930985	P5M-XCHANGE®	1	2928932





Hamilton

SGE Replacements for Hamilton Syringes.

Syringes and Accessories

Hamilton Product Code	Hamilton Part No.	SGE Product Code	SGE Part No.
1750-HITACHI	0160310	500C-HITACHI	007660
1701 N	80000	10F-GT	002200
1702WISP	80020	25D-WISP	003990
1725WISP	80024	250D-WISP	006690
1701RN(26s/51/2)	80030	10R-GT	002250
1701RNR - Rheodyne	80065	10R-GT-LC	002313
175ASN(23s/1.71"/HP)	80074	10F-AG-GT-0.63	002812
175ASN(23s-26s/1.71"/HP)	80076	5F-AG-0.63/0.47	001821
1701ASN(23s-26s/1.71"/HP)	80079	10F-AG-GT-0.63/0.47	002826
1701ASN(23s/1.71"/HP)	80080	10F-AG-GT-0.63	002812
175ASRN(23s-26s/1.71"/HP)	80086	5R-AG-0.63/0.47	001825
1701ASRN(23s/1.71 "/HP)	80087	10R-AG-GT-0.63	002818
1701ASRN(26s/1.71"/HP)	80088	10R-AG-GT-0.47	002817
1701ASRN(23S-26S/1.71"/HP)	80089	10R-AG-GT-0.63/0.47	002829
175ASN(23s/1.71"/HP)pk/6	80090	SK-5F-AG-0.63	001814
175ASN(23s-26s/1.71"/HP)pk/6	80092	SK-5F-AG-0.63/0.47	001822
1701ASN(23s/1.71"/HP)pk/6	80094	SK-10F-AG-GT-0.63	002813
1701ASN(23s-26s/1.71 "/HP)pk/6	80096	SK-10F-AG-GT-0.63/0.47	002827
7001KH(25s/2.75"/3)	80100	1BR-7/0.47	000570
1701ASRN(23s/1.71"/HP)	80176	1BR-AG-0.63	000610
1702N(22s/51/2)	80200	25F-GT	003200
1702RN(22s/51/2)	80230	25R-GT	003250
1702CX	80262	25D-CX-GT	003995
1702RNR - Rheodyne	80265	25R-GT-LC	003312
701N(26s/51/2)	80300	10F	002000
701RN(26s/51/2)	80330	10R	002050
701RN-HP(26s/2"/2)	80338	10R	002050
701SN(26s/2.75"/2)	80350	10F-7	002003
701ASRN(23s/1.71"/HP)	80357	10R-AG-0.63	002815
701ASRN(26s/1.71"/HP)	80358	10R-AG-0.47	002805
701ASRN(23s-26s/1.71"/HP)	80359	10R-AG-0.63/0.47	002825
901N	80360	10F-GP	002400
701NR - Rheodyne	80365	10F-LC	002301
701N 6p/k	80366	SK-10F	002030
901RN	80370	10R-GP	002450
701ASN(23s/1.71"/HP)	80387	10F-AG-0.63	002810
701ASN(26s/1.71"/HP)	80388	10F-AG-0.47	002800
701ASN(26s/1.71"/HP) Pkt6	80389	SK-10F-AG-0.47	002804
701ASN(23s/1.71"/HP) Pkt6	80390	SK-10F-AG-0.63	002814
701ASN(23s-26s/1.71"/HP)	80391	SK-10F-AG-0.63/0.47	002822
701ASN(23s-26s/1.71"/HP)	80393	10F-AG-0.63/0.47	002821
702N(22s/51/2)	80400	25F	003000
702SN(22/51/3)	80419	25F-LC	003300
702NR - Rheodyne	80465	25F-LC	003300
705N(22s/51/2)	80500	50F	004000
705LT	80501	50F-LT-GT	004229
705RN(22s/51/2)	80530	50R	004050
705CA (50 µL, 2.5")	80551	100F-LT-GT-6.5CA	005236
705NR(22s/51/3)	80565	50F-LC	004300
710N	80600	100F	005000
710LT	80601	100F-LT-GT	005229
710RN	80630	100R	005050
710NR(22s/51/3)	80665	100F-LC	005300
725N(22s/51/2)	80700	250F	006000
725LT	80701	250F-LT-GT	006229
725RN(22s/51/2)	80730	250R	006050
725SNR - Rheodyne	80765	250F-LC	006300
750N	80800	500F	007000
750LT	80801	500F-LT-GT	007229
750RN(22s/51/2)	80830	500R	007050

Hamilton Product Code	Hamilton Part No.	SGE Product Code	SGE Part No.
750SNR - Rheodyne	80865	500F-LC	007300
1705N(22s/51/2)	80900	50F-GT	004200
1705LT	80901	50F-LT-GT	004229
1705TLL	80920	50F-LL-GT	004230
1705RN	80930	50R-GT	004250
1705SL	80956	50R-V-GT	004279
1705CX	80962	50D-CX-GT	004995
1705RNR - Rheodyne	80965	50R-GT-LC	004312
1710N	81000	100F-GT	005200
1710LT	81001	100F-LT-GT	005229
1710TLL	81020	100F-LL-GT	005230
1710RN(22s/51/2)	81030	100R-GT	005250
1710SL	81056	100R-V-GT	005279
1710CX	81062	100D-CX-GT	005990
1710RNR - Rheodyne	81065	100R-GT-LC	005312
1725N(22s/51/2)	81100	250F-GT	006200
1725LT	81101	250F-LT-GT	006229
1725TLL	81120	250F-LL-GT	006230
1725RN	81130	250R-GT	006250
1725SL	81156	250R-V-GT	006279
1725CX	81162	250D-CX-GT	006995
1725RNR - Rheodyne	81165	250R-GT-LC	006312
1750LT	81201	500F-LT-GT	007229
1750RN	81230	500R-GT	007250
1750SL	81256	500R-V-GT	007279
1750CX	81262	500D-CX-GT	007995
1750RNR - Rheodyne	81265	500R-GT-LC	007312
1001LT	81301	1 MDF-LT-GT	008020
1001TLL	81320	1 MDF-LL-GT	008025
1001RN(22/51/2)	81330	1 MDR-GT	008100
1001SL	81356	1MDR-V-GT	008110
1001C	81360	1MD-C-GT	008185
1002LT	81401	2.5MDF-LT-GT	008420
1002TLL	81420	2.5MDF-LL-GT	008425
1002RN(22/51/2)	81430	2.5MDR-GT	008500
1002SL	81456	2.5MDR-V-GT	008510
1002C	81460	2.5MD-C-GT	008687
1005TLL	81520	5MDR-LL-GT	008760
1005RN(22/51/2)	81530	5MDR-GT	008700
1010W	81610	10MDF-LL-GT	008962
1010TLL	81620	10MDR-LL-GT	008960
1010RN(22/51/2)	81630	10MDR-GT	008900
1010C	81660	10MD-C-GT	008987
1025TLL	82520	25MDF-LL-GT	009463
801N(26s/51/2)	84852	10F-GP	002400
801RN(26s/51/2)	84853	10R-GP	002450
1801RN(26s/51/2)	84877	10R-GP-GT	002455
1050TLL	85020	50MR-LL-GT	009660
1100TLL	86020	100MR-LL-GT	009760
7000.5ASRN	86274	0.5BR-AG-0.47	000400
7000.5ASRN	86276	0.5BR-AG-0.63	000410
S0500 (TLL)	86311	500MAR-LL-GT	009910
S1000 (TLL)	86312	1000MAR-LL-GT	009920
S2000 (TLL)	86314	2000MAR-LL-GT	009930
1025SL	86326	25MDR-VLLMA-GT	009472*
1050SL	86336	50MR-VLLMA-GT	009670*
1100SL	86346	100MR-VLLMA-GT	009770*
701RNFS(0.17/10cm/3)	87402	10R-0C-100VS	002520
75N(26s/51/2)	87900	5F	001000

* Please note no needle fitted to the syringe.



Expert Tip :

If you can not find an equivalent syringe listed, contact SGE for a suitable alternative.



SGE Replacements for Hamilton Syringes continued

Hamilton Product Code	Hamilton Part No.	SGE Product Code	SGE Part No.
95N 5.0ul SYR (26s/2"/2)	87920	5F-GP	001400
95RN	87925	5R-GP	001450
75RN(26s/51/2)	87930	5R	001050
75ASRN(23s/1.71"/HP)	87957	5R-AG-0.63	001815
75ASRN(26S/1.71"/HP)	87958	5R-AG-0.47	001805
75ASRN(23s-26s/1.71"/HP)	87959	5R-AG-0.63/0.47	001825
75ASN(23s/1.7"/HP)	87987	5F-AG-0.63	001810
75ASN(26s/1.71"/HP)	87988	5F-AG-0.47	001800
75ASN(26s/1.71"/HP) Pk/6	87989	SK-5F-AG-0.47	001804
75ASN(23s/1.71"/HP) Pk/6	87990	SK-5F-AG-0.63	001814
75ASN(23s-26s/1.71"/HP)	87993	5F-AG-0.63/0.47	001821
75ASN(23s-26s/1.71"/HP) Pk6	87994	SK-5F-AG-0.63/0.47	001822
7105KH (24/2.75"/3)	88000	5BR-7	000802
7105KH (24/2.75"/2)	88011	5BR-7BV	000803
75ASN/PE-0.63	88035	5F-PE-0.63	001954
75ASN/PE-0.47	88040	5F-PE-0.47	001953
701N Fisons(0.47/80/AS)	202066	10F-C/T-8/0.47C	002992
701RSN-AOC14	202640	10R-S-0.63	002898
701 Varian	202880	10R-VA8X-2	002924
1702 CTC(26S/51/AS)	203043	25F-CTC-GT-5/0.47C	003700
701N CTC (26s/2)	203072	10F-CTC-5/0.47BV	002705
701N CTC (22s/3)	203073	10F-CTC-LC	002710
1702 CTC(26/AS) slim line	203074	25F-CTC-GT-5/0.47C	003700
1702NCTC(22S/51/3)	203075	25F-CTC-GT-LC	003715
1710 CTC(26S/51/AS)	203076	100F-CTC-GT-5/0.47C	005700
1710 CTC(22S/51/3)	203077	100F-CTC-GT-LC	005715
1725 CTC(26/51/AS)	203078	250F-CTC-GT-5/0.47C	006700
1725NCTC(22/51/3)	203079	250F-CTC-GT-LC (0.4)	006720
1750CTC (26s/AS)	203080	500F-CTC-GT-5/0.47C	007700
1001CTC (23/5)	203082	1MF-CTC-GT-HS-5/0.63H	008130
1002LTN CTC (22/51/3)	203083	2.5MR-CTC-GT-LC(0.41)	008620
1002CTC (23/5)	203084	2.5MF-CTC-GT-HS-5/0.63H	008630
1005LTN CTC (22/51/3)	203085	5MR-CTC-GT-LC(0.41)	008820
1001CTC (26/5)	203141	1MF-CTC-GT-HS-5/0.47H	008135
1002CTC (26/5)	203181	2.5MF-CTC-GT-HS-5/0.47H	008635
75N CTC (26s/AS)	203189	5F-C/T-5/0.47C	001982
1701 CTC(22S/51/3)	203194	10F-CTC-GT-LC	002715
701 N CTC (26s/AS)	203205	10F-CTC-5/0.47C	002700
1710N CTC (22s/3)	203235	100F-CTC-GT-LC (0.4)	005720
1750N CTC (22/3)	203349	500F-CTC-GT-LC (0.4)	007720
701N CTC (23s/AS)	203361	10F-C/T-5/0.63C	002981



SGE GC Capillary Column innovation, manufacture and selection	74-82
100% Dimethyl Polysiloxane	
BP1	83
BP1 PONA	84
BPX1	84

GC Capillary Columns

100% Dimethyl Polysiloxane in a Sol-Gel Matrix SolGel-1ms™	85
5% Phenyl / 95% Dimethyl Polysiloxane BP5	86
5% Phenyl Polysilphenylene-siloxane BPX5	87-88
5% Phenyl Polycarborane-siloxane HT5	89
8% Phenyl Polycarborane-siloxane HT8	90
35% Phenyl Polysilphenylene-siloxane BPX35	90-91
35% Phenyl Polysilphenylene-siloxane BPX608	91
50% Phenyl Polysilphenylene-siloxane BPX50	92
70% Cyanopropyl Polysilphenylene-siloxane BPX70	92-93
90% Cyanopropyl Polysilphenylene-siloxane BPX90	93
Polyethylene Glycol (PEG) in a Sol-Gel matrix SolGel-WAX™	94
Polyethylene Glycol BP20 (WAX)	94-95
Polyethylene Glycol (PEG) – TPA Treated BP21 (FFAP)	95-96
14% Cyanopropylphenyl Polysiloxane BP10 (1701)	96
50% Cyanopropylphenyl Polysiloxane BP225	97
Cyanopropylphenyl Polysiloxane BPX-VOLATILES	97
Cyanopropylphenyl Polysiloxane BP624	98
Permethyated Beta-Cyclodextrin (Chiral) CYDEX-B™	98
GC Applications by Industry	99-146

- Five decades of capillary column innovation.
- End to end capillary column manufacture.
- Providing separation solutions.



Five Decades of Capillary Column Innovation



SGE has a long history developing and producing GC capillary columns, with SGE's founder Ernest Dawes first being involved making glass capillary columns in 1959.

That expertise has been built upon with the development of leading capabilities in glass technology, polymer synthesis, surface chemistry and production processes all combined with an intimate knowledge of chromatography.

SGE develops and synthesizes specialty polymers leading to SGE being the first, and often only, capillary chromatography company to offer many types of GC stationary phases. SGE was the first to introduce the now industry standard silarylene phases in 1987 with their improved thermal stability, as well as SolGel in 1999 and the carborane phases in 1987. A detailed explanation of how these polymers work can be found on pages 76-80.

End to End Capillary Column Manufacture

SGE has long been a manufacturer of GC capillary columns with the complete technology capability to produce the finest capillary columns from beginning to end, including the special requirements of producing the fused silica capillary tubing. This end to end manufacturing capability allows SGE to control the fabrication process precisely to produce the finest quality capillary columns available.

The individual technologies SGE employs in GC capillary column manufacture are:

- Drawing of the precision fused silica capillary tubing.

- Developing and synthesizing the specialty polymer stationary phases.
- Performing the specialty chemical treatment of the fused silica surface so that it is inert and compatible for the cross-linked stationary phase.
- Coating and cross-linking the polymer stationary phase.
- Quality testing of every completed capillary column to rigorous standards.

Fused Silica

The process of producing fused silica at SGE is carried out on a series of sophisticated drawing towers with fine control of conditions and feedback loops to automatically make adjustments to the conditions. This ensures superb dimensional control and strength which is verified through stress proof testing of all material. By producing the fused silica ourselves, SGE has complete control of this important aspect of producing the highest quality GC capillary columns.

The fused silica used by SGE is very high purity devoid of impurities such as metal oxides found in conventional glasses. Depending on the application, SGE offers two types of FST coating - polyimide (max temp 400 °C) and aluminum (max. temperature 480 °C). SGE's capillary columns operate comfortably to 400 °C (dependent on the phase selected).

Stationary Phase Polymer

SGE has designed its phase synthesis so that most capillary columns may be washed with solvent to remove any contamination. When a capillary column's performance has deteriorated from extended use or contamination, performance can often be restored though washing with a suitable solvent. See page 196 for details and equipment available for washing capillary columns.

Rigorous Performance Testing

Test criteria are selected based on the applications that different capillary column types are targeted for, to ensure the capillary column meets the standards for that analysis. General purpose capillary columns are tested to ensure they meet inertness standards for difficult to chromatograph compounds, and run at conditions and levels designed to highlight variations in capillary column performance. For example, SGE's non-polar phase BPX5 is tested using active probes

such as n-decylamine and 2,4-dinitrophenol chromatographed at low concentrations (1-2 nanogram on capillary column for 0.25 µm film thickness) and with sufficient retained time on the run to induce tailing on all but the most highly inert capillary column. SGE does not offer separate ranges of capillary columns of different performance levels – all SGE GC capillary columns meet these high standards.

Retention Time and Consistency

Because SGE controls the capillary column fabrication process from beginning to end we are also able to achieve remarkably consistent retention characteristics from column to column. When a method is established on an SGE column, the same separation can be expected column after column.

Thermal Stability

A long term issue in capillary GC is the breakdown of the stationary phase in the capillary column at elevated temperatures which leads to rising and noisy baseline signals thereby limiting sensitivity of the analysis. Stationary phase breakdown at elevated temperatures cannot be eliminated but it can be reduced dramatically through improving the technology. SGE developed, and was the first to introduce, silarylene - containing polymers such as silphenylene stationary phases in 1987. Silphenylene phases replace some of the oxygen atoms in the backbone of the siloxane polymer with aromatic groups. This led to a dramatically improved thermal stability for GC phases with silphenylene phases now available in a wide range of polarities and selectivities. SGE capillary columns are monitored for bleed performance with rigorous standards established. Bleed is measured and specified in terms of detector signal and calibrated to "nanograms of siloxane per second" eluted from the capillary columns. **The test is performed at the maximum operating temperature for the capillary column.**



The measure for bleed of nanograms of siloxane per second eluting from the capillary column is more meaningful than exclusively reporting picoamp FID signal. Picoamp signal is highly dependent on the detector and conditions used and is not an

absolute measure. SGE carries out the bleed measurement on FID to assure the best performance possible.

Below is an example of the SGE GC Capillary Column Performance Report.

Part Number: Re-order information.

Serial Number Column Traceability: Every SGE GC column is traceable back to its manufacture.

Measure of Theoretical Plates/meter: This is a measure of the efficiency of the column.

Maximum continuous temperature: This is the maximum recommended temperature for the column. Higher temperatures can be used, but this will reduce column lifetime.

Capacity Ratio: This is a measure of the film thickness.

Kovats Index: Describes the retention behavior of a compound relative to that of straight chain hydrocarbons. Especially important for more polar columns.

Skew: This is a measure of the degree of tailing (1.0 = Perfect).

Thermal Stability: Each column is bleed tested to its maximum continuous operating temperature.

Providing Separation Solutions

GC Capillary Columns Polarity Scale

SGE strives to develop a better understanding of the interactions of the solute molecules with the GC stationary phase types in our product range and those we could design and synthesize. The objective is to be able to assist you the chromatographer to select a GC stationary phase for the separation of particular classes of compounds.

All chromatographers want the best separation and need to focus on the key parameters that influence the resolution equation. R can be viewed in three sections consisting of variables which influence capillary column efficiency, retention and selectivity.

$$R = \underbrace{\left(\frac{\sqrt{N}}{4}\right)}_{\text{Column Efficiency}} \underbrace{\left(\frac{k}{k+1}\right)}_{\text{Retention}} \underbrace{\left(\frac{\alpha-1}{\alpha}\right)}_{\text{Selectivity}}$$

R = resolution, N = theoretical plates, k = capacity factor, α = selectivity

Another way of viewing the resolution equation from the GC capillary column perspective is that quality impacts the capillary column efficiency, the physical dimensions of the capillary column influence retention and the phase chemistry dictates selectivity. Inevitably, many GC operators focus on flow rates and temperatures because of their importance in getting good peak shapes and nice separations – rarely do we pay attention to how the phase can have such an effect on the relative retention time. The fine detail of the chromatography comes in the interaction with the phase.

Stationary Phase Polarity

A discussion on phase chemistry inevitably involves a reference to polarity – polarity in general terms and where phases fit along a linear polarity scale – but there is more

to it than this. There are different types of interactions based on the different types of functionality of the GC stationary phase polymer. In trying to create a scaled representation of the mechanisms of separation SGE has placed the stationary phases against a qualitative scale, although this scale is analyte dependent. The scale reflects the relative ability of phases to interact with particular types of analytes.

The scales shown in the 3D Phase Polarity diagram below, are qualitative rather than quantitative and have been derived from experimental work studying the retention of different analytes in the different types of stationary phases. Essentially the focus has been to develop a three dimensional representation of where each phase fits as a point on a plot of three classic bonding mechanisms - 'Van der Waals', H-bonding and π -bonding.

3D Phase Polarity Scale

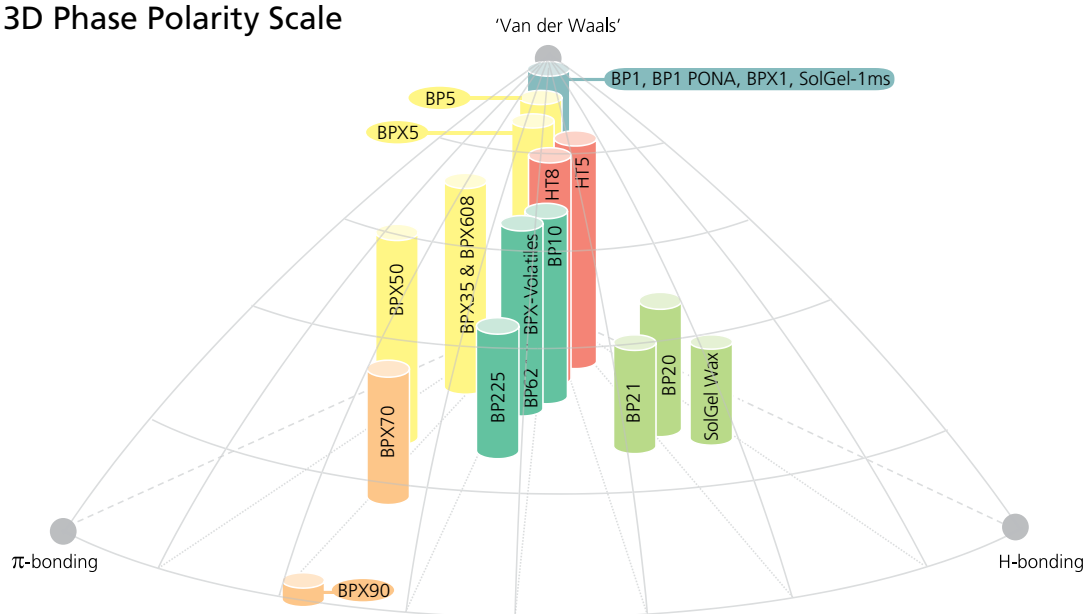

- Dimethyl Polysiloxane
- Phenyl Polysilphenylene Siloxane
- Cyanopropyl Polysilphenylene Siloxane
- Polycarborane Siloxane
- Cyanopropylphenyl Siloxane
- Polyethylene Glycol

Bonding Mechanisms

Van der Waals – essentially electrostatic attraction from temporary dipoles and are a very weak interaction. They are at their greatest relative contribution in the non-polar phases like the dimethylsiloxanes.

Hydrogen bonding results from the attraction of positive and negative charges of hydrogen and non-bonding pairs of electrons and is the force that holds water molecules together as liquid.

The π -bonding is associated with the aromatic class of compounds that include

benzene rings. Molecules with these loose clouds of donut shaped electronic charges have their own attraction towards each other. The π -bond in benzene is perpendicular to the benzene ring bonds so they interact more easily if the shape of the molecules does not create steric hindrance.

Stationary phases consist of basic polymer units with functionalities that can be modified by the addition of various moieties during synthesis. These moieties can be added in various amounts to create different concentrations of a particular functionality.

SGE GC Capillary Column Phases

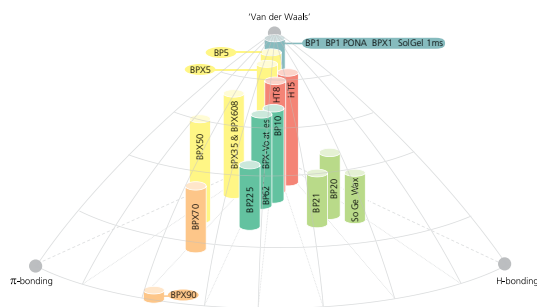

GC Columns and Applications

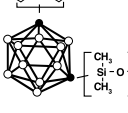
Color Code	Phase	Structure	SGE Phase	Characteristics
●	Dimethyl Polysiloxane	$\left[\begin{array}{cc} \text{CH}_3 & \text{CH}_3 \\ & \\ \text{---Si---O---Si---O---} \\ & \\ \text{CH}_3 & \text{CH}_3 \end{array} \right]_n$	BP1 BP1 PONA BPX1 SolGel-1ms	<ul style="list-style-type: none"> Polydimethylsiloxane (PDMS) "non-polar" type phases which rely on Van der Waals interactions between molecules and separate primarily based on "boiling point" type separation. Useful chromatographic space is usually considered in terms of modifications to non-polar retention. This is understandable because the GC is useful for volatile compounds and that usually means organics. Organics that can be vaporized are generally high in non-polar (alkane or hydrocarbon) character. It is this part of their surface that allows them to be soluble in a non-polar phase. It is also this characteristic that makes the BP1 (dimethylsiloxane) a universal phase.
●	Diphenyl Dimethyl Siloxane (Phenyl substituted Siloxanes)	$\left[\begin{array}{cc} \text{C}_6\text{H}_5 & \text{C}_6\text{H}_5 \\ & \\ \text{---Si---O---Si---O---} \\ & \\ \text{CH}_3 & \text{CH}_3 \end{array} \right]_{5\%}$	BP5	<ul style="list-style-type: none"> The classical 5% phenyl group of phases
●	Phenyl Polysilphenylene Siloxane (Silphenylene substituted Polydimethylsiloxane)	$\left[\begin{array}{cc} \text{C}_6\text{H}_5 & \text{C}_6\text{H}_5 \\ & \\ \text{---Si---O---Si---O---} \\ & \\ \text{C}_6\text{H}_4 & \text{C}_6\text{H}_4 \end{array} \right]_y$	BPX5 BPX35 BPX608 BPX50	<ul style="list-style-type: none"> Silphenylene phases have become fairly common now with many manufacturers offering at least some phases of this type, SGE has a full range. Phases with the "X" notation have a silphenylene backbone (exception is the BPX1). Phenyl substituted polymers are relatively non-polar and rely for their different functionality on π - bonding with the aromatic phenyl groups. SGE was the first GC capillary column manufacturer to introduce this type of phase commercially in the 1980s with the intention of improving the thermal stability to give higher maximum temperatures and reduced bleed.
●	Polycarborane Siloxane	$\left[\begin{array}{c} \text{C}_6\text{H}_5 \\ \\ \text{---Si---O---} \\ \\ \text{C}_6\text{H}_5 \end{array} \right]_x$ 	HT5 HT8	<ul style="list-style-type: none"> The carborane phases were originally developed as very high thermal stability phases for high temperature work to 460 °C. The functionality of the carboranes is difficult to explain – they end up with pentavalent bonds with shared sigma bonds rather than π - bonds. The bonds are transient like a benzene with a ball of shared electrons. HT5 and HT8 are low π - bonding purely due to the low concentration of carborane in the polymer, otherwise it would be high.
●	Cyanopropylphenyl Siloxane	$\left[\begin{array}{cc} \text{CH}_3 & \text{CN} \\ & \\ \text{---Si---O---Si---O---} \\ & \\ \text{CH}_3 & \text{C}_6\text{H}_4 \end{array} \right]_y$	BP225 BP10 BP624 BPX-Volatiles	<ul style="list-style-type: none"> 'Polar' phases with <50% cyanopropyl substituted dimethylpolysiloxane.
●	Cyanopropyl Polysilphenylene Siloxane	$\left[\begin{array}{cc} \text{C}_6\text{H}_5 & \text{CN} \\ & \\ \text{---Si---O---Si---O---} \\ & \\ \text{C}_6\text{H}_4 & \text{C}_6\text{H}_4 \end{array} \right]_y$	BPX70 BPX90	<ul style="list-style-type: none"> High cyanopropyl substituted phases, are more difficult to make as efficient, thermally stable phases. BPX70 is equivalent to and behaves like a 70% cyanopropyl siloxane but with siphenyl end substituted backbone for stability which was introduced in 1987 and remained the most polar thermally stable phase for a long time. BPX90 which is equivalent to a 90% cyanopropyl siloxane and stable to 300 °C which is excellent for such a polar phase. The prominent interaction for BPX90 is π - π bonding with the cyano group; the cyano groups become almost entirely responsible for the partitioning.
●	Polyethylene Glycol	$\text{---CH}_2\text{---CH}_2\text{---O---}$	BP21 BP20 SolGel-WAX™	<ul style="list-style-type: none"> (PEG) 'wax' type phases where the main separation mechanisms are hydrogen bonding or dipole interactions. The wax phases are often considered as ideal for mixtures of chemically different components such as those contained in essential oils.

Choosing the Right Phase for Your Separation

So how can you use this elaborate explanation of phases and bonding types? The answer is simple! In separation science we seek solutions in resolving complex mixtures and a “one-phase fits all” is more a hope than a reality. Here SGE has explored different phases from a polarity scale to assist the chromatographer to choose the best combination of phases which provide an orthogonal solution rather than a simple variation of a theme.

Take for example the separation of aromatics on the polyethylene glycol capillary column BP20 (H-bonding) compared to BP1 where the primary interaction is Van der Waals. Whereas para- and meta-xylene are unresolved on BP1, they are clearly resolved on BP20 with a corresponding change in elution order to the alkanes. This is an interesting interaction because the aromatic xylenes have been attracted by the H-bond rich BP20. It is not a totally ‘one or the other’ situation when judging the contribution of H-bond and π -bond affinities, because they have some affinity for each other.

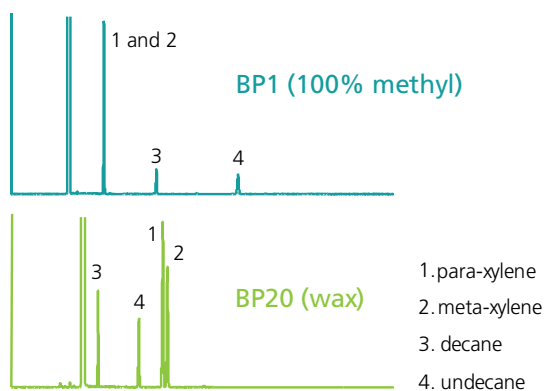

A higher component separation is demonstrated with a series of hydrocarbons run on a relatively non-polar phase (BPX5, on the x-axis in figure above right) and on a highly polar BPX90 with the retention times plotted on the y-axis. If the hydrocarbon family is split up on the basis of unsaturated

groups, this extra dimension shown in color (chemical group) reveals that the plot shows strong correlations for retention characteristics and functional chemistry.

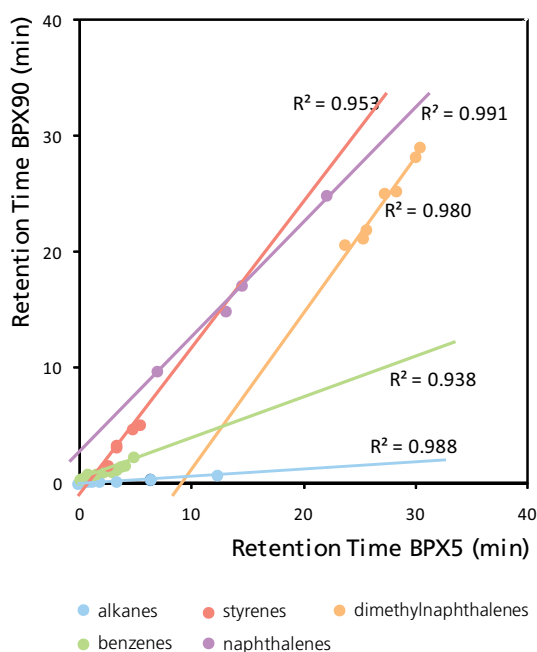

In this case, the hydrocarbon alkanes (light blue) are completely non-polar. They are retained on the phase only because the phase has sufficient non-polar character to interact with them. In the case of BPX90, it is so polar that it does not offer alkanes the opportunity for interaction. As a result, the alkanes tend to elute almost unretained. The alkanes show almost perfect orthogonality here. Retention on BPX5 versus no retention on BPX90 – they lie almost along the x-axis. We can now reason that if pure hydrocarbons (Van der Waals or non-polar interactions) give little or no BPX90 retention then retention of the remaining aromatics is due to purely π type interactions. When comparing GC phases, departures from the diagonal mark a significant change in the retention mechanism.

In conclusion, polar phases offer selectivity based on functionality rather than on Van der Waals interactions and are an ideal choice for the separation of analytes that were unresolved on non-polar or moderately polar phases.

The primary advantages of considering phase selectivity include:

- 2D GC – the choice of orthogonal chemistries for the 1st and 2nd dimensions.
- Fast GC – highly retained analytes on non-polar phases elute much earlier on polar phases.
- Ubiquitous FAMES methods.
- Separation of unresolved analytes due to alternative functionality.

SGE hopes this information assists in your understanding of optimum GC capillary column phase selection for your application. Following is a summary of phase, plus other capillary column parameters such as internal diameter, capillary column length and film thickness, to assist with identification of the right SGE GC capillary column for your separation solution.

GC Capillary Column Selection

1. Stationary Phase

- Select the least polar phase that will perform the separation you require.
- Non-polar stationary phases separate analytes predominantly by order of boiling point. Increase the amount of phenyl and/or cyanopropyl content in the phase, and the separation is then influenced more by differences in dipole moments or charge distributions (BP10 (1701), BPX35, BPX50, BP225 and BPX70).

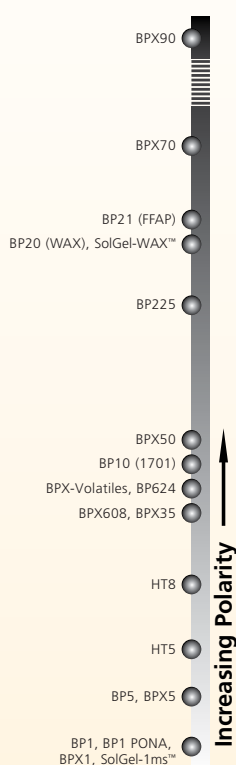

OPs on Aromatic Phases

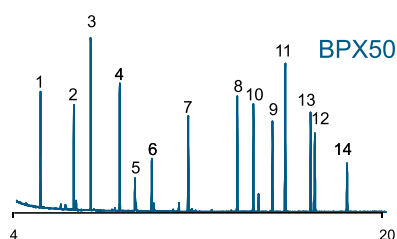
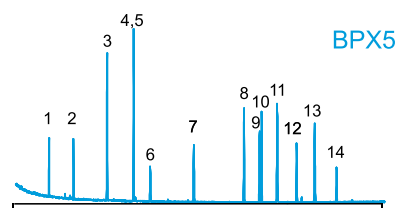

Organophosphorus Pesticides

- | | |
|-------------------------------------|------------------------|
| 1. 4-Chloro-3-nitrobenzotrifluoride | 7. Chlorfenvinphos |
| 2. 1-Bromo-2-nitrobenzene | 8. Ethion |
| 3. Tributylphosphate | 9. Famphur |
| 4. Terbufos | 10. Carbophenothion |
| 5. Dioxathion | 11. Triphenylphosphate |
| 6. Phoshamidon | 12. Phosmet |
| | 13. Leptophos |
| | 14. Azinphos-ethyl |

Columns	30 m x 0.25 mm x 0.25 μm
Initial Temp	45 °C (1 min)
1st Temp Ramp	30 °C/min to 200 °C (0.1 min)
2nd Temp Ramp	7 °C/min
Final Temp	315 °C (hold 10 min)
Injector Temp	280 °C
Splitless Time	1 min
Carrier	He, 1 ml.min
Instrument	HP 6890/5973

Effect of increasing Phenyl content in the stationary phase.

- To separate compounds that differ more in their hydrogen bonding capacities (for example aldehydes and alcohols), polyethylene glycol type phases are best suited - SolGel-WAX™, BP20 (WAX) and BP21(FFAP).

2. Internal Diameter

- The smaller the diameter the greater the efficiency, hence better resolution. Fast columns (0.1 mm ID) are used for faster analysis because the same resolution can be achieved in a shorter time.

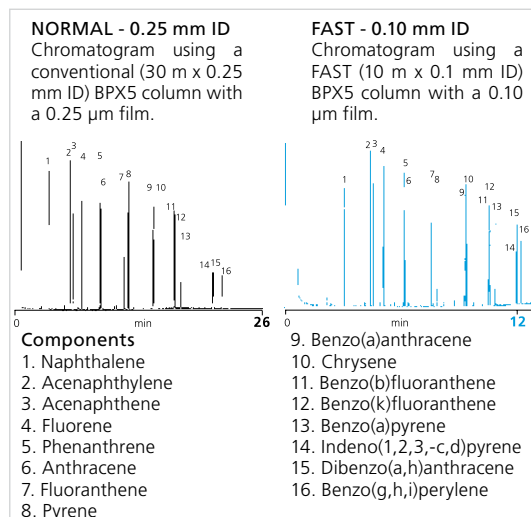

Effect of Internal Diameter. Polynuclear Aromatic Hydrocarbon (PAH) analysis.

3. Film Thickness

- For samples with a variation in solute concentration, a thicker film column is recommended. This will reduce the possibility of broad overloaded peaks co-eluting with other compounds of interest. If the separation of two solutes is sufficient and co-elution is still unlikely, even with large differences in concentration, then a thinner film can be used.
- The greater the film thickness the greater the retention of solutes, therefore the higher the elution temperature. As a rule, doubling the film thickness results in an increase in elution temperature of approximately 15-20 °C under isothermal conditions. Using a temperature program, the increase in elution temperature is slightly less.
- From the phase ratio value β , a column can be categorized for the type of application it would best suit. The smaller the β value, the greater the ratio of phase to the column inner diameter, making it better suited for analyzing volatile compounds.

Columns that have thin films are generally better suited for high molecular weight compounds and are characterized by large β values.

- Maintain phase ratio among different ID columns to yield similar chromatography.

$$\beta = \frac{id}{4d_f}$$

where

β = phase ratio

id = column internal diameter (μm)

d_f = film thickness (μm)

Formula to calculate Phase Ratio.

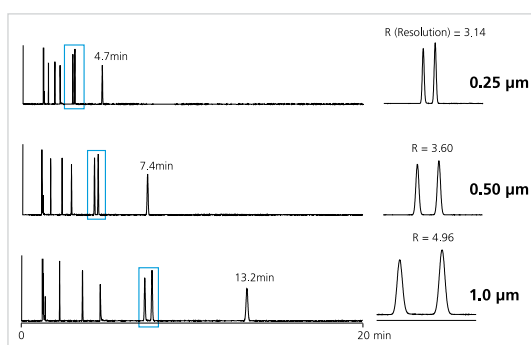

Effect of Film Thickness.

Film Thickness (μm)	Column ID (μm)					
	100	150	220	250	320	530
0.10	250	-	550	625	800	1325
0.15	-	250	-	-	-	883
0.25	-	150	220	250	320	530
0.50	-	75	110	125	160	265
1.00	-	-	55	63	80	132
3.00	-	-	-	-	27	44
5.00	-	-	-	-	16	26

Table 1. Above shows the phase ratio (β) available for the SGE range of capillary columns. Keeping a similar phase ratio when changing column internal diameters will ensure that your chromatographic parameters will not need substantial changes.

4. Column Length

- Always try to select the shortest column length that will provide the required resolution for the application. If the maximum column length available is being used and resolution of the sample mixture is still inadequate then try changing the stationary phase or internal diameter.
- Resolution is proportional to the square root of the column efficiency; therefore, doubling the column length will only increase the resolving power of the column by approximately 40%.

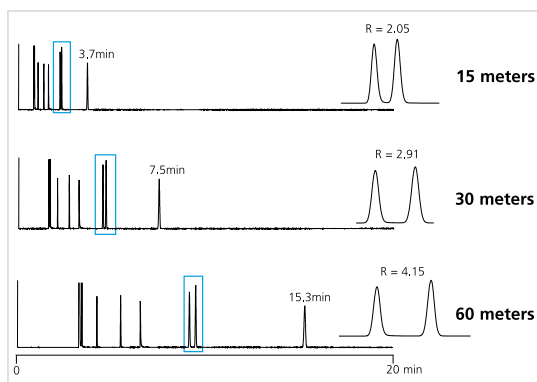

Effect of Length.

Application Range For Varying Phase Ratios

Phase Ratio (β)	Application
16-100	Gases, Low M.W. Hydrocarbons, Solvents, Volatile Halogens (M.W.16-250)
100-320	Semi-volatiles, General Applications (M.W. 100-700)
320-1325	High M.W. Hydrocarbons, Waxes, Petroleum Products (M.W. 300-1500)

SGE GC Capillary Column Phase Cross Reference Table

SGE Phase	Description	Capillary Column to Replace
BP1	100% Dimethyl Polysiloxane	DB-1, HP-1, Ultra-1, SPB-1, CP-Sil 5CB, RSL-150, RSL-160, Rtx [®] -1, ZB-1, CB-1, OV [®] -1, PE-1, 007-1(MS), SP-2100, SE-30, RH-1, CC-1, CP-Sil 5CB MS, VF-1ms, Petrocol DH
BP1-PONA	100% Dimethyl Polysiloxane	Petrocol DH, DB-Petro
BPX1	100% Dimethyl Polysiloxane	DB-HT Sim Dis, DB-2887, Rtx-2887, HP-1, Petrocol 2887, Petrocol EX2887
SolGel-1ms™	SolGel + 100% Dimethyl Polysiloxane	Unique highly inert phase
BP5	5% Phenyl Polysiloxane	DB-5, DB-5.625, Rtx-5, HP-5, Ultra-2, PTE-5, PB-5, MDN-5, CP-Sil 8CB, VB-5 & ZB-5
BPX5	5% Phenyl Polysilphenylene-siloxane	DB-5, DB-5ms, HP-5, Ultra-2, Rtx [®] -5, Rtx-5Sil MS, Rtx 5MS, AT-5, AT-5MS, 007-5MS, SPB-5,CP-Sil 8CB, VF-5ms, RSL-200, CB-5, OV [®] -5, PE-5, 007-2(MPS-5), SE-52, SE-54, XTI-5, PTE-5, CC-5, RH-5ms, ZB-5
BPX35	35% Phenyl Polysilphenylene-siloxane	DB-35, DB-35ms, Rtx-35, HP-35, HP-35MS, SPB-35, MDN-35, VB-50, ZB-35
BPX608	35% Phenyl Polysilphenylene-siloxane	DB-608, Rtx-35, SPB-608
BPX50	50% Phenyl Polysilphenylene-siloxane	OV-17, SP-2250, DB-17ms, DB-17ht, Rtx-50, SPB-50, HP-50+, HP-17, VB-50/608, ZB-50
HT5	5% Phenyl Polycarborane-siloxane	MXT-1 SimDist, HT-SimDist, DistCB, MXT-500
HT8	8% Phenyl Polycarborane-siloxane	No equivalent, unique high temperature capillary column with special selectivity (standard for PCB)
BP225	50% Cyanopropylphenyl Polysiloxane	HP-225, DB-225, Rtx-225
BP10 (1701)	14% Cyanopropylphenyl Polysiloxane	DB-1701, Rtx-1701, HP-1701, SPB-7, CP-Sil 19CB, VB-1701, ZB-1701
BP624, BPX-Volatiles	Cyanopropylphenyl Polysiloxane	DB-624, HP-VOC, Rtx Volatiles, Rtx 624, VOCOL, VB-624, ZB-624
BPX70	70% Cyanopropyl Polysilphenylene-siloxane	DB-23, CP-Sil 88, VF-23ms, SP-2330, SP-2380, Rtx [®] -2330, 007-23, AT-Silar, PE-23
BPX90	90% Cynopropyl Polysilphenylene-siloxane	Unique highly polar phase
BP21 (FFAP)	Polyethylene Glycol (TPA treated)	DB-FFAP, HP-FFAP, Stabilwax-DA, CP Wax 58CB, VB-FFAP, ZB-FFAP
BP20 (Wax)	Polyethylene Glycol	DB-Wax, Rtx-Wax, Stabilwax, HP20M, HP-Wax, HP-INNOWax, Supelcowax-10, AT-Wax, Nukol, CP Wax 2CB, VB-WAX, ZB-WAX
SolGel-WAX™	SolGel + Polyethylene Glycol	Unique highly inert phase
CYDEX-B	Permethyated Beta Cyclodextrin	Cyclodex-B, Rt-BDEXm

Operating Temperature

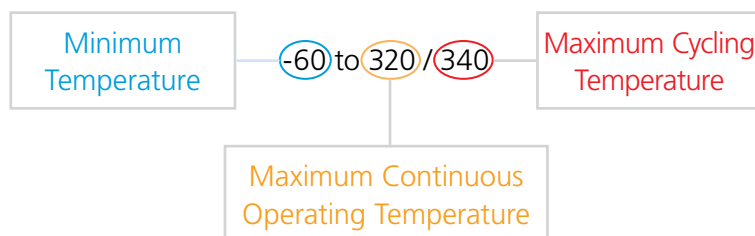

For each SGE GC column phases temperature limits are represented three ways:



Minimum Temperature	Maximum Continuous Operating Temperature	Maximum Cycling Temperature
The temperature below which the capillary column will not separate components due to loss of partitioning in the stationary phase.	The maximum temperature at which a capillary column can be held for 72 hours with no significant change. SGE capillary columns are designed to pass all criteria measured by their test analysis after 72 hours at their Maximum Continuous Operating Temperature.	The maximum cycling temperature to which a capillary column can be taken for short periods (up to 30 minutes) without causing serious bleed problems or degradation of the phase. This is usually higher than the Maximum Continuous Operating Temperature. The lifetime of a capillary column is affected by the amount of time it spends at high temperatures.

BP1

- Classic crosslinked dimethyl polysiloxane technology.
- Excellent general purpose GC column.
- Low bleed.
- Non-polar.
- Suitable for all routine analyses.
- 320 – 340 °C upper temperature limit – dependent on film thickness.

Especially Suitable for these Industries:	 Fuels  Environment  Forensics
Application Areas:	Suitable for analysis of hydrocarbons, aromatics, pesticides, phenol, herbicides, amines. Applications AMI04, POL05, PHA04.
Suitable Replacement for:	DB-1, DB-Petro, HP-1, HP-1MS, Rtx-1, Ultra-1, SPB-1, SPB-1 Sulfur, Petrocol DH, CP-Sil 5CB, VB-1, ZB-1, VF-1ms.

ID (mm)	Film Thickness (µm)	Length (m)	Temperature Limits (°C)	Part No.
0.1	0.1	10	-60 to 320/340	054022
0.15	0.25	12	-60 to 320/340	054028
0.15	0.25	25	-60 to 320/340	054029
0.22	0.1	12	-60 to 320/340	054040
0.22	0.25	12	-60 to 320/340	054046
0.22	1	12	-60 to 320/340	054052
0.22	0.25	15	-60 to 320/340	054049
0.22	0.1	25	-60 to 320/340	054041
0.22	0.25	25	-60 to 320/340	054047
0.22	1	25	-60 to 320/340	054053
0.22	0.25	30	-60 to 320/340	054050
0.22	0.1	50	-60 to 320/340	054042
0.22	0.25	50	-60 to 320/340	054048
0.22	1	50	-60 to 320/340	054054
0.22	0.25	60	-60 to 320/340	054051
0.25	0.1	15	-60 to 320/340	054039
0.25	0.25	15	-60 to 320/340	054043
0.25	0.25	30	-60 to 320/340	054044
0.25	0.5	30	-60 to 320/340	054820
0.25	1	30	-60 to 320/340	054056
0.25	0.25	60	-60 to 320/340	054045
0.25	0.5	60	-60 to 320/340	054812
0.25	1	60	-60 to 320/340	054815
0.32	0.25	12	-60 to 320/340	054058
0.32	0.5	12	-60 to 320/340	054064
0.32	1	12	-60 to 320/340	054070
0.32	0.25	15	-60 to 320/340	054061
0.32	0.25	25	-60 to 320/340	054059
0.32	0.5	25	-60 to 320/340	054065
0.32	1	25	-60 to 320/340	054071
0.32	4	25	-60 to 280/300	054076
0.32	5	25	-60 to 280/300	054081
0.32	0.25	30	-60 to 320/340	054062
0.32	0.5	30	-60 to 320/340	054068
0.32	1	30	-60 to 320/340	054813
0.32	1.5	30	-60 to 300/320	054811
0.32	3	30	-60 to 300/320	054073
0.32	4	30	-60 to 280/300	054077
0.32	0.25	50	-60 to 320/340	054060
0.32	0.5	50	-60 to 320/340	054066
0.32	1	50	-60 to 320/340	054072
0.32	5	50	-60 to 280/300	054082
0.32	0.25	60	-60 to 320/340	054067

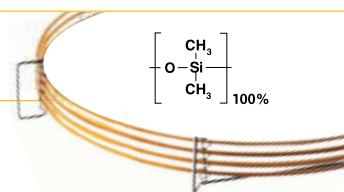

GC Columns and Applications

Expert Tip :

Columns should be conditioned to the maximum continuous temperature unless specified.



GC Columns and Applications

ID (mm)	Film Thickness (µm)	Length (m)	Temperature Limits (°C)	Part No.
0.32	0.5	60	-60 to 320/340	054069
0.32	1	60	-60 to 320/340	054810
0.32	5	60	-60 to 280/300	054085
0.53	1	12	-60 to 320/340	054086
0.53	3	12	-60 to 300/320	054097
0.53	0.5	15	-60 to 320/340	054870
0.53	1	15	-60 to 320/340	054089
0.53	1	25	-60 to 320/340	054087
0.53	3	25	-60 to 300/320	054098
0.53	5	25	-60 to 280/300	054095
0.53	0.5	30	-60 to 320/340	054092
0.53	1	30	-60 to 320/340	054090
0.53	2.6	30	-60 to 300/320	054819
0.53	3	30	-60 to 300/320	054808
0.53	5	30	-60 to 280/300	054806
0.53	1	50	-60 to 320/340	054088
0.53	5	50	-60 to 280/300	054096
0.53	0.5	60	-60 to 320/340	054871
0.53	3	60	-60 to 300/320	054809
0.53	5	60	-60 to 280/300	054807

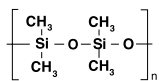

BP1 PONA

- Designed for the analysis of petroleum products.
- Non-polar phase for PONA analysis.
- Detailed hydrocarbon analysis according to ASTM (DHA-method).
- Crosslinked and washable.
- Very high resolving power columns for complex samples.
- 320 – 340 °C upper temperature limit.

Especially Suitable for this Industry:	 Fuels
Application Areas:	Suitable for petroleum hydrocarbons, gasoline range hydrocarbons, MTBE, paraffins, olefins, naphthenes, aromatics. Application PET01.
Suitable Replacement for:	Petrocol DH, DB-Petro, HP-PONA, AT-Petro, Elite-PONA, ZB-1, 007-1-100-0.5F, Rtx-1PONA, CP Sil PONA.

ID (mm)	Film Thickness (µm)	Length (m)	Temperature Limits (°C)	Part No.
0.15	0.5	50	-60 to 320/340	054950
0.25	0.5	100	-60 to 320/340	054818

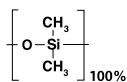

BPX1

- Non-polar column.
- Dimensionally stabilized phase.
- Low bleed.
- Specifically designed for high temperature hydrocarbon analysis.
- Ideal for simulated distillation methods (ASTM Method D2887).
- 430 °C upper temperature limit – Aluminum clad.
- 370- 400 °C upper temperature limit – Polyimide clad (dependent on film thickness).

Especially Suitable for this Industry:	 Fuels
Application Areas:	ASTM methods D2887 and D6532. Applications PET26, PET18, ENV54.
Suitable Replacement for:	DB-2887, DB-HT Sim Dis, HP-1, Petrocol 2887, Petrocol EX2887, Rtx-2887.

BPX1

ID (mm)	Film Thickness (µm)	Length (m)	Temperature Limits (°C)	Part No.
Polyimide Clad				
0.1	0.1	10	-30 to 400/400	054777
0.53	2.65	6	-30 to 370/370	0548025
0.53	0.1	10	-30 to 400/400	054803
0.53	0.9	10	-30 to 400/400	054801
0.53	2.65	10	-30 to 370/370	054802
Aluminum Clad				
0.53	0.1	5	-30 to 430/430	054800
0.53	0.17	5	-30 to 430/430	054782
0.53	0.1	10	-30 to 430/430	054779

GC Columns and Applications

GC Capillary Columns | 100% Dimethyl Polysiloxane in a Sol-Gel Matrix

SolGel-1ms™

What is Sol-Gel?

Sol-Gel is essentially a synthetic glass with ceramic-like properties. These modified Sol-Gels offer the best of both worlds – ceramic-like properties with the film-forming properties of the associated polymer. The Sol-Gel process involves hydrolysis and condensation of alkoxides that lead to the formation of a glassy material at ambient temperatures. This method has been used to produce high quality ceramics and mono- and multi-component glasses of high homogeneity and purity. The further modification of this ceramic material with polymeric material (with appropriate functionality) leads to the formation of organic-inorganic nanomaterials.

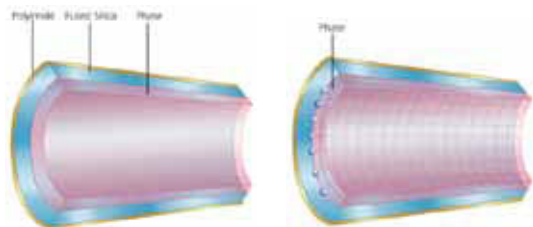

Conventional Phase
The phase is coated onto the surface of the fused silica resulting in weak intermolecular bonding, ie no covalent bonding, ie no anchoring.

Sol-Gel Phase
Anchored to the surface of the fused silica through covalent bonding.

Where can Sol-Gel materials be used?

The further organic-modified Sol-Gels have been incorporated in a variety of high-end technology products including membrane chemical and pH sensors, films for protection of optical lenses, cosmetic and electronic products.

SGE and Sol-Gel materials?

At SGE, Sol-Gel processes are used to manufacture stationary phases for gas chromatography capillary columns. SGE is the first company to offer Sol-Gel technology capillary columns. The organic component in our case is a GC stationary phase. The final Sol-Gel product has all the properties of the GC phase as well as the additional properties of the Sol-Gel part. The Sol-Gel material is able to covalently bond to the surface of the fused silica. The 'heavy-duty' bonding imparts better thermal stability of the phase leading to ultra-low bleed capillary columns. To date, two Sol-Gel phases have been developed by SGE, namely SolGel-1ms™ and SolGel-WAX™. The SolGel-1ms™ stationary phase is a non-polar phase derived from 100% dimethyl polysiloxane. SolGel-WAX™ is a polar phase which incorporates polyethylene glycol in the matrix.

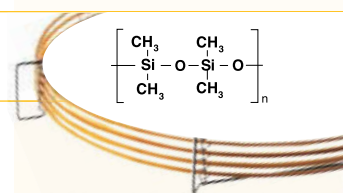

Expert Tip :



Always use SilTite™ or SilTite™ Finger-Tite ferrules when connecting a column to a GC/MS interface.



SolGel-1ms™ has a robust, inert, high temperature, non-polar phase for use with mass spectrometers.

- Highly inert.
- Less bleed means:
 - Better MS library identification.
 - Less ion source maintenance.
 - Better sensitivity.
- Can also be used for all non-MS detectors.
- Same selectivity as BP1.
- 340 /360 °C upper temperature limit.

GC Columns and Applications

Especially Suitable for these Industries:	  
Application Areas:	Recommended for highly active compounds. Applications ARO14, ENV51.
Operating Temperature:	0.25 µm film thickness 0 °C to 340/360 °C.
Suitable Replacement for:	DB-1, DB-Petro, HP-1, HP-1MS, Rtx-1, Ultra-1, SPB-1, SPB-1 Sulfur, Petrocol DH, CP-Sil 5CB, VB-1, ZB-1, VF-1ms.

ID (mm)	Film Thickness (µm)	Length (m)	Temperature Limits (°C)	Part No.
0.25	0.25	30	0 to 340/360	054795
0.25	0.25	60	0 to 340/360	054793
0.32	0.25	30	0 to 340/360	054798
0.32	0.25	60	0 to 340/360	054794

GC Capillary Columns | 5% Phenyl / 95% Dimethyl Polysiloxane

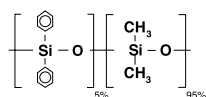

BP5

- Excellent general purpose GC column.
- Low bleed.
- Non-polar.
- High temperature.
- 320/340 °C upper temperature limit - dependent on film thickness.

Especially Suitable for these Industries:	
Application Areas:	General purpose, aromatics, pesticides, herbicides, drugs of abuse, hydrocarbons, solvent impurities, PCB congeners or Aroclor mixes, essential oils, semivolatiles. Applications FOO02, AMI03, PHA08, PHA 10.
Suitable Replacement for:	DB-5, Rtx-5, HP-5, Ultra-2, PTE-5, SPB-5, MDN-5, CP-Sil 8CB, VB-5, ZB-5.

ID (mm)	Film Thickness (µm)	Length (m)	Temperature Limits (°C)	Part No.
0.22	0.25	12	-60 to 320/340	054167
0.22	0.25	25	-60 to 320/340	054168
0.22	0.25	30	-60 to 320/340	054171
0.22	0.25	50	-60 to 320/340	054169
0.22	1	50	-60 to 320/340	054175
0.25	0.25	15	-60 to 320/340	054182
0.25	0.25	30	-60 to 320/340	054183
0.25	0.5	30	-60 to 320/340	054202
0.25	1	30	-60 to 320/340	054203

For your instrument specific septa see the Instrument Quick Pick Guide on pages 167-180.

BP5

ID (mm)	Film Thickness (µm)	Length (m)	Temperature Limits (°C)	Part No.
0.25	0.25	60	-60 to 320/340	054184
0.25	1	60	-60 to 320/340	054215
0.32	0.25	12	-60 to 320/340	054179
0.32	0.25	15	-60 to 320/340	054176
0.32	0.25	25	-60 to 320/340	054180
0.32	0.5	25	-60 to 320/340	054186
0.32	1	25	-60 to 320/340	054192
0.32	0.25	30	-60 to 320/340	054177
0.32	0.5	30	-60 to 320/340	054216
0.32	1	30	-60 to 320/340	054189
0.32	0.5	50	-60 to 320/340	054187
0.32	1	50	-60 to 320/340	054193
0.32	0.25	60	-60 to 320/340	054178
0.32	1	60	-60 to 320/340	054188
0.53	1	12	-60 to 320/340	054197
0.53	1	15	-60 to 320/340	054194
0.53	1.5	15	-60 to 320/340	054199
0.53	1	25	-60 to 320/340	054198
0.53	0.5	30	-60 to 320/340	0541935
0.53	1	30	-60 to 320/340	054195
0.53	5	30	-60 to 280/300	054196
0.53	1.5	60	-60 to 280/300	054204

GC Columns and Applications

Expert Tip :

If the injection port temperature is not specified in the method, 250 °C is usually the recommended temperature.



GC Capillary Columns | 5% Phenyl Polysilphenylene-siloxane

BPX5

- High temperature.
- General purpose GC column – suitable for over 80% of all routine analyses performed by gas chromatography.
- Very low bleed – ideal for trace analysis.
- Non-polar.
- Extremely inert.
- Ideal for GC-MS.
- 360 – 370 °C upper temperature limit – dependent on film thickness.

Recommended column for General Purpose use.

Especially Suitable for these Industries:	 All Industries
Areas:	Ultra trace analyses, pesticides/herbicides, hydrocarbons, solvents, phenols, amines, GC/MS and other specific detector applications. Applications ENV62, ARO09, ENV20, ENV03, ENV48, ENV59, ENV84, FOO21, FLA14, FLA16, FLA15, FLA12 FLA13, ENV54, PET22, SOL33 PHA06, PHA08, PHA15.
Suitable Replacement for:	DB-5, DB-5ms, DB-5.625, XTI-5, Rtx-5ms, Ultra-2, HP-5, HP-5MS, HP5-TA, SPB-5, MDN-5S, CP-Sil8CB, Rxt-Sil 5MS, AT-5ms, VB-5, ZB-5, VF-5ms.

ID (mm)	Film Thickness (µm)	Length (m)	Temperature Limits (°C)	Part No.
0.1	0.1	10	-40 to 360/370	054099
0.15	1.2	10	-40 to 360/370	054106
0.15	0.25	12	-40 to 360/370	054103
0.15	0.4	12	-40 to 360/370	054107
0.15	0.25	25	-40 to 360/370	054104
0.15	0.4	25	-40 to 360/370	054108

BPX5

GC Columns and Applications

Expert Tip :

If you're having problems with solvent focusing, or early eluting peaks seem broad or lop-sided in splitless injection, then try using a column with a thicker film.



ID (mm)	Film Thickness (µm)	Length (m)	Temperature Limits (°C)	Part No.
0.15	0.15	30	-40 to 360/370	054110
0.15	0.25	50	-40 to 360/370	054105
0.18	0.18	40	-40 to 360/370	054229
0.22	0.25	12	-40 to 360/370	054112
0.22	0.25	25	-40 to 360/370	054113
0.22	1	25	-40 to 360/370	054116
0.22	0.25	30	-40 to 360/370	054142
0.22	0.25	50	-40 to 360/370	054114
0.22	1	50	-40 to 360/370	054117
0.25	0.25	7	-40 to 360/370	054149
0.25	0.1	15	-40 to 360/370	0542170
0.25	0.25	15	-40 to 360/370	054100
0.25	1	15	-40 to 360/370	054121
0.25	0.1	30	-40 to 360/370	0541011
0.25	0.25	30	-40 to 360/370	054101
0.25	0.5	30	-40 to 360/370	0541025
0.25	1	30	-40 to 360/370	054122
0.25	0.25	60	-40 to 360/370	054102
0.25	1	60	-40 to 360/370	054123
0.32	1	6	-40 to 360/370	0541261
0.32	0.25	12	-40 to 360/370	054118
0.32	0.5	12	-40 to 360/370	054124
0.32	1	12	-40 to 360/370	054127
0.32	0.25	15	-40 to 360/370	054144
0.32	1	15	-40 to 360/370	054152
0.32	0.25	25	-40 to 360/370	054119
0.32	0.5	25	-40 to 360/370	054125
0.32	1	25	-40 to 360/370	054128
0.32	3	25	-40 to 350/360	054136
0.32	0.25	30	-40 to 360/370	054145
0.32	0.5	30	-40 to 360/370	0541205
0.32	1	30	-40 to 360/370	054153
0.32	0.25	50	-40 to 360/370	054120
0.32	0.5	50	-40 to 360/370	054126
0.32	1	50	-40 to 360/370	054129
0.32	0.25	60	-40 to 360/370	054146
0.32	1	60	-40 to 360/370	054154
0.53	0.25	12	-40 to 360/370	054133
0.53	1	12	-40 to 360/370	054130
0.53	3	12	-40 to 350/360	054138
0.53	0.5	15	-40 to 360/370	0541344
0.53	1	15	-40 to 360/370	054147
0.53	1.5	15	-40 to 350/360	0541347
0.53	3	15	-40 to 350/360	054159
0.53	0.25	25	-40 to 360/370	054134
0.53	1	25	-40 to 360/370	054131
0.53	3	25	-40 to 350/360	054139
0.53	0.5	30	-40 to 360/370	0541345
0.53	1	30	-40 to 360/370	054148
0.53	1.5	30	-40 to 350/360	0541348
0.53	3	30	-40 to 350/360	054160
0.53	1	50	-40 to 360/370	054132
0.53	1	60	-40 to 360/370	054158

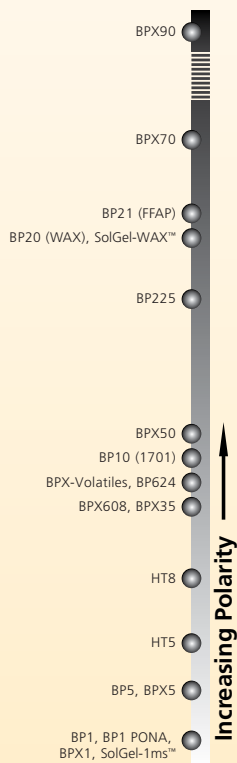

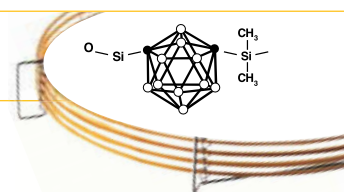

HT5



GC Columns and Applications

- Ultra high temperature columns.
- Unique phase – no equivalent phases.
- Ideal for simulated distillation applications (petroleum industry).
- 460/480 °C upper temperature limit – Aluminum clad.
- 380/400 °C upper temperature limit – Polyimide clad.
- Bonded and cross-linked.
- Able to be solvent rinsed.

Especially Suitable for these Industries:	  
Application Areas:	Simulated distillation, general hydrocarbon profiles, pesticides/herbicides, GC/MS applications. Applications FOO16, PET11, PET27, PET06.
Suitable Replacement for:	MXT-1 Sim Dist, HT-Sim, DistCB, MXT-500.

ID (mm)	Film Thickness (µm)	Length (m)	Temperature Limits (°C)	Part No.
Polyimide Clad				
0.22	0.1	12	10 to 380/400	054631
0.22	0.1	25	10 to 380/400	054632
0.25	0.1	15	10 to 380/400	054633
0.25	0.1	30	10 to 380/400	054634
0.32	0.1	12	10 to 380/400	054641
0.32	0.5	15	10 to 380/400	054667
0.32	0.1	25	10 to 380/400	054642
0.32	0.5	30	10 to 380/400	054668
0.53	0.1	6	10 to 380/400	054655
0.53	0.5	10	10 to 380/400	054670
0.53	0.15	12	10 to 380/400	054657
0.53	0.5	15	10 to 380/400	054671
0.53	0.15	25	10 to 380/400	054658
0.53	0.5	30	10 to 380/400	054672
Aluminum Clad				
0.22	0.1	12	10 to 460/480	054635
0.22	0.1	25	10 to 460/480	054636
0.32	0.1	12	10 to 460/480	054651
0.32	0.1	25	10 to 460/480	054652
0.32	0.1	50	10 to 460/480	054653
0.53	0.075	5	10 to 460/480	054673
0.53	0.1	6	10 to 460/480	054661
0.53	0.15	12	10 to 460/480	054662
0.53	0.15	25	10 to 460/480	054665

Expert Tip :

To prevent increasing retention times in your chromatography, replace the septum regularly.



For your gas purifiers see pages 165-166.

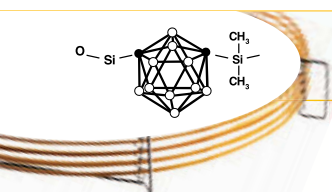

HT8

- High temperature.
- Low bleed.
- Preferred column for polychlorinated biphenyl (PCB) compounds.
- Separates PCB's on ortho ring substitution as well as boiling point.
- Ideal for environmental analysis.
- 360/370 °C upper temperature limit.
- Unique high temperature phase suited for the analysis of persistent organic pollutants (POPs).

GC Columns and Applications

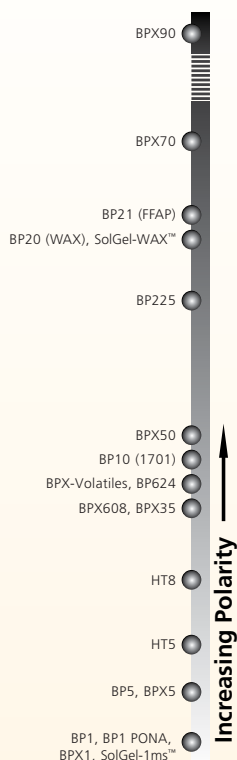

Especially Suitable for this Industry:	 Environment
Application Areas:	PCB congener analyses, nitro-substituted aromatics, polynuclear aromatic hydrocarbons, pesticides/herbicides. Application ARO08.
Suitable Replacement for:	No equivalents, unique ultra high temperature column.



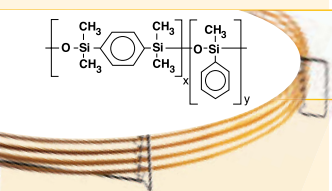

ID (mm)	Film Thickness (µm)	Length (m)	Temperature Limits (°C)	Part No.
0.1	0.1	10	-20 to 360/370	054690
0.22	0.25	12	-20 to 360/370	054674
0.22	0.25	25	-20 to 360/370	054675
0.22	0.25	50	-20 to 360/370	054676
0.25	0.25	30	-20 to 360/370	054677
0.25	0.25	60	-20 to 360/370	054683
0.32	0.25	12	-20 to 360/370	054679
0.32	0.25	25	-20 to 360/370	054680
0.32	0.25	50	-20 to 360/370	054681
0.32	0.25	60	-20 to 360/370	054682
0.53	0.5	12	-20 to 360/370	054684
0.53	0.5	25	-20 to 360/370	054685

GC Capillary Columns | 35% Phenyl Polysilphenylene-siloxane



BPX35

- Mid polarity column.
- Ideal for confirmational analysis.
- Inert.
- Equivalent to USP phase G42.
- High temperature.
- Very low bleed.
- Pharmaceutical specialist.
- 330/360 °C upper temperature limit.
- Bonded and cross-linked.
- Able to be solvent rinsed.

Especially Suitable for these Industries:	    Pharmaceuticals Environment Food Forensics
Application Areas:	Environmental analyses, pesticides/herbicides, drugs of abuse, pharmaceuticals, polynuclear aromatic hydrocarbons, GC/MS applications. Applications ENV57, ENV04 AMI09, ALC09, SOL25, PHA14, PHA09
Suitable Replacement for:	DB-35, DB-35ms, Rtx-35, HP-35, HP-35MS, SPB-35, MDN-35.

BPX35

ID (mm)	Film Thickness (µm)	Length (m)	Temperature Limits (°C)	Part No.
0.1	0.1	10	10 to 330/360	054699
0.22	0.25	15	10 to 330/360	054713
0.22	0.25	25	10 to 330/360	054711
0.22	0.25	30	10 to 330/360	054714
0.22	0.25	50	10 to 330/360	054712
0.25	0.25	15	10 to 330/360	054700
0.25	1	15	10 to 330/360	054703
0.25	0.25	30	10 to 330/360	054701
0.25	0.5	30	10 to 330/360	0547025
0.25	1	30	10 to 330/360	054704
0.25	0.25	60	10 to 330/360	054702
0.25	1	60	10 to 330/360	054705
0.32	0.25	15	10 to 330/360	054723
0.32	0.5	15	10 to 330/360	054718
0.32	1	15	10 to 330/360	054716
0.32	0.25	25	10 to 330/360	054721
0.32	0.25	30	10 to 330/360	054724
0.32	0.5	30	10 to 330/360	0547158
0.32	1	30	10 to 330/360	054717
0.32	0.25	50	10 to 330/360	054722
0.53	0.5	15	10 to 330/360	054734
0.53	1	15	10 to 330/360	054736
0.53	0.5	30	10 to 330/360	054735
0.53	1	30	10 to 330/360	054737

GC Columns and Applications

Expert Tip :

When peak shape deteriorates, replace the liner immediately and cut 30cm from the front end of the column.



GC Capillary Columns | 35% Phenyl Polysilphenylene-siloxane

BPX608

- Optimized for ECD.
- Ideal for organochlorine, pesticides and herbicides analysis.
- Maximum temperature 370 °C.

Especially Suitable for these Industries:	 Environment
Application Areas:	Environmental analyses, EPA 608, pesticides/herbicides.
Operating Temperature	10 °C to 360/370 °C.
Suitable Replacement for:	DB-608, Rtx-35, SPB-608, HP-35, ZB-35.

ID (mm)	Film Thickness (µm)	Length (m)	Temperature Limits (°C)	Part No.
0.32	0.4	25	10 to 360/370	054823

For your instrument specific septa see the Instrument Quick Pick Pages 167-180.

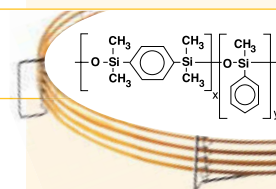

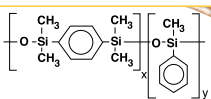

BPX50

- Mid polarity.
- Inert.
- Low bleed.
- High temperature.
- Ideal for a range of EPA methods and pharmaceutical applications.
- 330/350 °C upper temperature limit.
- Bonded and cross-linked.
- Able to be solvent rinsed.

GC Columns and Applications

Especially Suitable for these Industries:



Application Areas: EPA methods 604, 608, 8060, 8081, triazines/herbicides, drug screening, steroids and a variety of pharmaceutical applications GC2D. Applications ENV62, ENV45, ENV65, PHA19.

Suitable Replacement for: OV-17, SP-2250, DB-17, DB-17ms, DB-17ht, Rtx-50, SPB-50, HP-50+, HP-17.

Expert Tip :

When installing your column into an FID jet, never pass the column through the flame. This will burn the inner (phase) and outer (polyimide) coatings and will cause higher background signals.



ID (mm)	Film Thickness (µm)	Length (m)	Temperature Limits (°C)	Part No.
0.1	0.05	10	80 to 330/350	054739
0.1	0.07	10	80 to 330/350	054738
0.1	0.1	10	80 to 330/350	054740
0.15	0.15	30	80 to 330/350	054741
0.25	0.25	15	80 to 330/350	054750
0.25	0.25	30	80 to 330/350	054751
0.25	0.25	60	80 to 330/350	054752
0.32	0.25	15	80 to 330/350	054760
0.32	0.25	30	80 to 330/350	054761
0.32	0.25	60	80 to 330/350	054762
0.53	0.5	15	80 to 330/350	054770
0.53	0.5	30	80 to 330/350	054771
0.53	1.0	30	80 to 330/350	054772

GC Capillary Columns | 70% Cyanopropyl Polysilphenylene-siloxane

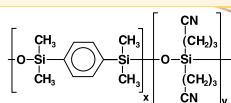

BPX70

- High temperature.
- Custom designed for separation of Fatty Acid Methyl Esters (FAMES).
- Industry standard column for FAME analysis.
- Polar phase.
- Long operating life.
- 250/260 °C upper temperature limit.
- Bonded and cross-linked.
- Able to be solvent rinsed.

Especially Suitable for these Industries:



Application Areas: Fatty acid methyl esters (FAMES), carbohydrates, pharmaceuticals, GC/MS applications. Applications FOO02, FOO04.

Suitable Replacement for: DB-23, Rtx-2330, SP-2330, CP-Sil 88, SP2380, HP-23.

BPX70

ID (mm)	Film Thickness (µm)	Length (m)	Temperature Limits (°C)	Part No.
0.1	0.2	10	50 to 250/260	054600
0.22	0.25	12	50 to 250/260	054601
0.22	0.25	25	50 to 250/260	054602
0.22	0.25	30	50 to 250/260	054612
0.22	0.25	50	50 to 250/260	054603
0.22	0.25	60	50 to 250/260	054613
0.25	0.25	15	50 to 250/260	054621
0.25	0.25	30	50 to 250/260	054622
0.25	0.25	60	50 to 250/260	054623
0.25	0.25	120	50 to 250/260	054624
0.32	0.25	12	50 to 250/260	054605
0.32	0.25	25	50 to 250/260	054606
0.32	0.25	30	50 to 250/260	054616
0.32	0.25	50	50 to 250/260	054607
0.32	0.25	60	50 to 250/260	054617
0.53	0.5	15	50 to 250/260	054619
0.53	0.5	25	50 to 250/260	054610
0.53	0.5	30	50 to 250/260	054620

GC Columns and Applications

Expert Tip :

Set the FID temperature 20 °C above the maximum method temperature.







GC Capillary Columns | 90% Cyanopropyl Polysilphenylene-siloxane

BPX90

- Unique bonded phase.
- Highly polar.
- Thermally stable.
- Excellent resolution for cis and trans isomers.
- 260/280 °C upper temperature limit.
- Able to be solvent rinsed.

For your gas purifiers see page 165-166.

Especially Suitable for these Industries:	   
Application Areas:	Ideal for fast separation of fragrances, aromatics, petrochemical, pesticides, PCBs and isomers of Fatty Acid Methyl Esters (FAMES). Application AN0022C.
Suitable Replacement for:	Unique to SGE.

ID (mm)	Film Thickness (µm)	Length (m)	Temperature Limits (°C)	Part No.
0.25	0.25	15	80 to 260/280	054570
0.25	0.25	30	80 to 260/280	054580
0.25	0.25	60	80 to 260/280	054590
0.25	0.25	100	80 to 260/280	054596
0.32	0.5	15	80 to 260/280	054573
0.32	0.5	30	80 to 260/280	054583
0.32	0.5	60	80 to 260/280	054593

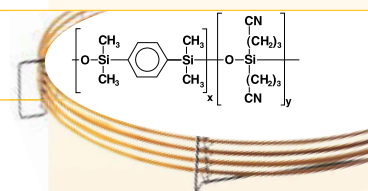

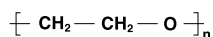

GC Capillary Columns | Polyethylene Glycol (PEG) in a Sol-Gel matrix



SolGel-WAX™

GC Columns and Applications

- The world's highest temperature wax phase.
- Bonded polyethylene glycol.
- Very robust high-temperature column.
- Less susceptible to damage by oxygen than conventional wax phases.
- Polar phase.
- Low bleed and inert.
- 280 °C upper temperature limit.
- Bonded and cross-linked.
- Able to be solvent rinsed.

Especially Suitable for these Industries:	 
Application Areas:	Recommended for highly active compounds. Applications ARO13, FLA19, FLA22, FLA21, FLA18, POL06, ENV52.
Suitable Replacement for:	DB-Wax, Rtx-Wax, Stabilwax, HP20M, HP-Wax, HP-INNOWax, Supelcowax-10, AT-Wax, Nukol, CP Wax 52CB, VB-WAX, ZB-WAX.

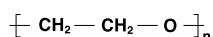

ID (mm)	Film Thickness (µm)	Length (m)	Temperature Limits (°C)	Part No.
0.1	0.1	10	30 to 260/280	0547100
0.25	0.25	30	30 to 260/280	054796
0.25	1	30	30 to 260/280	054787
0.25	0.25	60	30 to 260/280	054791
0.32	0.25	30	30 to 260/280	054788
0.32	0.5	30	30 to 260/280	054797
0.32	0.25	60	30 to 260/280	054789
0.32	0.5	60	30 to 260/280	054792
0.53	0.5	30	30 to 260/280	054786
0.53	1	30	30 to 260/280	054785

GC Capillary Columns | Polyethylene Glycol



BP20 (WAX)

- Industry standard wax column.
- Polar phase.
- 240 – 280 °C upper temperature limit – dependent on film thickness.
- Bonded and cross-linked.
- Able to be solvent rinsed.

Especially Suitable for these Industries:	  
Application Areas:	Alcohol, free acids, fatty acid methyl esters (FAMES), aromatics, solvents, essential oils. Applications FOO03, FOO24 FLA03, ALC03, ACI03, POL01, PHA13.
Suitable Replacement for:	DB-Wax, HP-20M, Supelcowax 10, CB-Wax, Stabilwax, Carbowax, HP-Innowax, Rtx-WAX, PE-WAX, RH-WAX, ZB-WAX, TRWAX.

BP20 (WAX)

ID (mm)	Film Thickness (µm)	Length (m)	Temperature Limits (°C)	Part No.
0.1	0.1	10	20 to 260/280	054405
0.22	0.25	12	20 to 260/280	054420
0.22	0.25	25	20 to 260/280	054421
0.22	0.25	30	20 to 260/280	054424
0.22	0.25	50	20 to 260/280	054422
0.22	0.25	60	20 to 260/280	054425
0.25	0.25	15	20 to 260/280	054426
0.25	0.25	30	20 to 260/280	054427
0.25	0.5	30	20 to 260/280	054415
0.25	1	30	30 to 240/260	054439
0.25	0.25	60	20 to 260/280	054428
0.25	0.5	60	20 to 260/280	054458
0.32	0.25	15	20 to 260/280	054432
0.32	0.25	25	20 to 260/280	054430
0.32	0.5	25	20 to 260/280	054436
0.32	1	25	20 to 240/260	054442
0.32	0.25	30	20 to 260/280	054433
0.32	0.5	30	20 to 260/280	054438
0.32	1	30	30 to 240/260	054444
0.32	0.25	50	20 to 260/280	054431
0.32	0.5	50	20 to 260/280	054437
0.32	1	50	20 to 240/260	054443
0.32	0.25	60	20 to 260/280	054434
0.32	0.5	60	20 to 260/280	054457
0.32	1	60	20 to 240/260	054445
0.53	1	12	20 to 240/260	054447
0.53	2	12	20 to 240/260	054455
0.53	0.5	15	20 to 260/280	054961
0.53	1	15	20 to 240/260	054450
0.53	1	25	20 to 240/260	054448
0.53	2	25	30 to 240/260	054456
0.53	0.5	30	20 to 260/280	054440
0.53	1	30	20 to 240/260	054451
0.53	0.5	60	20 to 260/280	054963
0.53	1	60	20 to 240/260	0544515

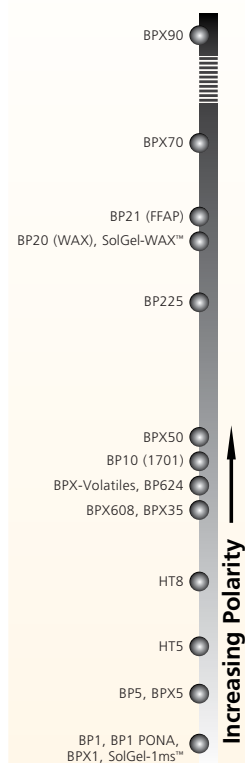

GC Columns and Applications



GC Capillary Columns | Polyethylene Glycol (PEG) – TPA Treated

BP21 (FFAP)

- Nitroterephthalic acid modified PEG.
- Polar phase.
- Ideal for low molecular weight acids.
- 240/250 °C upper temperature limit.
- Able to be solvent rinsed (water or methanol is NOT recommended for rinsing).
- Bonded and cross-linked.

Especially Suitable for these Industries:	  
Application Areas:	Volatile free acids, fatty acid methyl esters, alcohols, aldehydes, acrylates, ketones. Applications AC102, SOL04.
Suitable Replacement for:	DB-FFAP, HP-FFAP, Stabilwax-DA, CPWax-58CB.

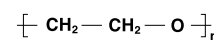

BP21 (FFAP)

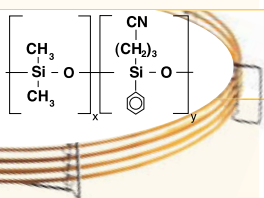

ID (mm)	Film Thickness (µm)	Length (m)	Temperature Limits (°C)	Part No.
0.22	0.25	25	35 to 240/250	054462
0.22	0.25	50	35 to 240/250	054463
0.25	0.25	15	35 to 240/250	054464
0.25	0.25	30	35 to 240/250	054465
0.25	0.25	60	35 to 240/250	054466
0.32	0.25	12	35 to 240/250	054467
0.32	0.25	15	35 to 240/250	054470
0.32	0.25	25	35 to 240/250	054468
0.32	0.25	30	35 to 240/250	054471
0.32	0.25	50	35 to 240/250	054469
0.32	0.25	60	35 to 240/250	054472
0.32	0.5	50	35 to 240/250	054480
0.53	0.5	12	35 to 240/250	054473
0.53	0.5	15	35 to 240/250	054476
0.53	0.5	25	35 to 240/250	054474
0.53	0.5	30	35 to 240/250	054477
0.53	1	30	35 to 240/250	054478

GC Columns | 14% Cyanopropylphenyl Polysiloxane



BP10 (1701)

- Used for organochlorine pesticides analysis.
- Highly inert.
- Low bleed.
- 260/300 °C upper temperature limit - dependent on film thickness.
- Bonded and cross-linked.
- Able to be solvent rinsed.

Especially Suitable for these Industries:	  
Application Areas:	Environmental analyses (EPA methods 608 and 8081), pesticides/herbicides, drugs of abuse, pharmaceuticals.
Suitable Replacement for:	DB-1701, Rtx-1701, SPB-7, HP-1701, CP-Sil 19CB, 007-1701, PE-1701, SP-1701.

ID (mm)	Film Thickness (µm)	Length (m)	Temperature Limits (°C)	Part No.
0.22	0.25	12	-20 to 280/300	054252
0.22	0.25	25	-20 to 280/300	054253
0.22	0.25	50	-20 to 280/300	054254
0.25	0.25	15	-20 to 280/300	054255
0.25	0.25	30	-20 to 280/300	054256
0.25	1	30	-20 to 260/280	054271
0.25	0.25	60	-20 to 280/300	054257
0.32	0.25	15	-20 to 280/300	054258
0.32	0.5	15	-20 to 280/300	054264
0.32	0.25	25	-20 to 280/300	054262
0.32	0.5	25	-20 to 280/300	054268
0.32	0.25	30	-20 to 280/300	054259
0.32	0.5	30	-20 to 280/300	054265
0.32	1	30	-20 to 260/280	054270
0.32	0.5	50	-20 to 280/300	054269
0.32	0.25	60	-20 to 280/300	054260
0.32	0.5	60	-20 to 280/300	054266
0.53	1	15	-20 to 260/280	054282
0.53	1	25	-20 to 260/280	054280
0.53	1	30	-20 to 260/280	054283

Expert Tip :

Do not use plastic tubing in GC systems. Plastic tubing, when used for general plumbing, can absorb up to 20% moisture allowing external laboratory gases to permeate through the tubing. SGE recommends clean stainless steel tubing to be used throughout the GC system.



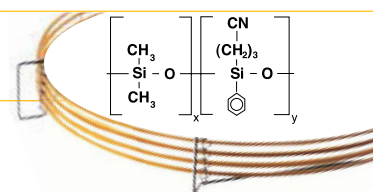

BP225

- Mid to high polarity.
- Low bleed.
- Bonded and cross-linked.
- 230/260 °C upper temperature limit.
- Able to be solvent rinsed.



GC Columns and Applications

Especially Suitable for these Industries:	 
Application Areas:	Fatty Acid Methyl Esters (FAMES), carbohydrates, neutral sterols.
Suitable Replacement for:	DB-225, HP-225 and RTX-225.

ID (mm)	Film Thickness (µm)	Length (m)	Temperature Limits (°C)	Part No.
0.22	0.25	25	40 to 230/260	054352
0.22	0.25	50	40 to 230/260	054353
0.32	0.25	25	40 to 230/260	054358
0.53	0.5	25	40 to 230/260	054364



For your instrument specific septa see the Instrument Quick Pick Guide pages 167-180.

GC Columns | Cyanopropylphenyl Polysiloxane

BPX-VOLATILES

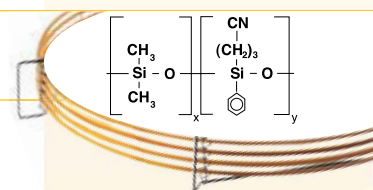
- Polar phase.
- EPA volatile organics analysis (EPA 624, 502.2, SW-846 8240/8260).
- 290/300 °C upper temperature limit.
- Able to be solvent rinsed.
- Bonded and cross-linked.



Especially Suitable for these Industries:	  
Application Areas:	Environmental analyses, volatile organics, alcohol analysis, USP G43. Application TP-0102-C.
Suitable Replacement for:	DB-VRX, HP-624, OPTIMA 624, ELITE-624, 007-624, RTX-VOLATILES, SPB-624, TRV1, CPSIL 13 CB, VOCOL, VB-624, CP-624.

ID (mm)	Film Thickness (µm)	Length (m)	Temperature Limits (°C)	Part No.
0.18	1	20	0 to 290/300	054978
0.18	1	40	0 to 290/300	054979
0.25	1.4	30	0 to 290/300	054980
0.25	1.4	60	0 to 290/300	054981
0.32	1.8	30	0 to 290/300	054982
0.32	1.8	60	0 to 290/300	054983
0.53	3	30	0 to 290/300	054984
0.53	3	60	0 to 290/300	054985

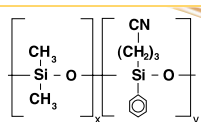

BP624

- US EPA 624 optimized column.
- Designed for volatiles analysis.
- Ideal for EPA624, SW-846 methods 8240/8260.
- Ideal for USP G43 method.
- 230/240 °C upper temperature limit.
- Able to be solvent rinsed.
- Bonded and cross-linked.

GC Columns and Applications

Especially Suitable for these Industries:	 Environment
Application Areas:	EPA method 624, drinking water volatiles, chlorinated hydrocarbons, solvents, Excellent for U.S. EPA Methods: 501.3, 502.2, 503.1, 524.2, 601, 602, 8010, 8015, 8020, 8240, 8260. Applications ENV17, ENV13.
Suitable Replacement for:	DB-624, OV-624, AT-624, HP-VOC, CP-Select624CB, 007-624, Rtx-Volatiles, Rtx 624, VOCOL, ZB-624.

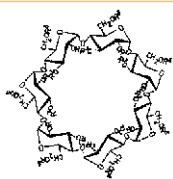

ID (mm)	Film Thickness (µm)	Length (m)	Temperature Limits (°C)	Part No.
0.22	1.2	25	0 to 230/240	054826
0.22	1.2	30	0 to 230/240	054827
0.25	1.4	15	0 to 230/240	054839
0.25	1.4	30	0 to 230/240	054840
0.25	1.4	60	0 to 230/240	054842
0.32	1.8	25	0 to 230/240	054830
0.32	1.8	30	0 to 230/240	054832
0.32	1.8	50	0 to 230/240	054831
0.32	1.8	60	0 to 230/240	054841
0.53	3	25	0 to 230/240	054834
0.53	3	30	0 to 230/240	054836
0.53	3	50	0 to 230/240	054835
0.53	3	60	0 to 230/240	054838

GC Columns | Permethyated Beta-Cyclodextrin (Chiral)



CYDEX-B™

- Separation of chiral compounds

Especially Suitable for these Industries:	 Pharmaceuticals  Food
Application Areas:	Separation of enantiomeric compounds found in natural products. Application FLA05.
Operating Temperature:	30 °C to 220/240 °C
Suitable Replacement for:	Cyclodex-B, Rt-BDEXm, LIPODEX C

ID (mm)	Film Thickness (µm)	Length (m)	Temperature Limits (°C)	Part No.
0.22	0.25	25	30 to 220/240	054900
0.22	0.25	50	30 to 220/240	054901
0.32	0.25	25	30 to 220/240	054902

ENV 62 | Polynuclear Aromatic Hydrocarbons (PAH) Analysis on BPX50

Column Part No.:	054751		
Phase:	BPX50, 0.25 µm film	Flow:	On
Column:	30 m x 0.25 mm ID	Average Linear Velocity:	39 cm/sec at 65 °C
(PAH) standard:	10 ng/ µL in dichloromethane	Mode of Injection:	splitless
Initial Temp.:	65 °C, 0.5 min	Purge on Time:	0.5 min.
Rate 1.:	25 °C/min to 140 °C	Purge on (split) Vent Flow:	60 mL/min
Rate 2.:	10 °C/min to 325 °C	Injection Volume:	0.2 µL
Final Temp.:	325 °C, 15 min	Injection Temp.:	250 °C
Detector Type:	MSD	Autosampler:	No
Carrier Gas:	Helium, 9.7 psi	Liner Type:	4 mm ID Double Taper
Carrier Gas Flow:	1.1 mL/min constant	Liner Part Number:	092018

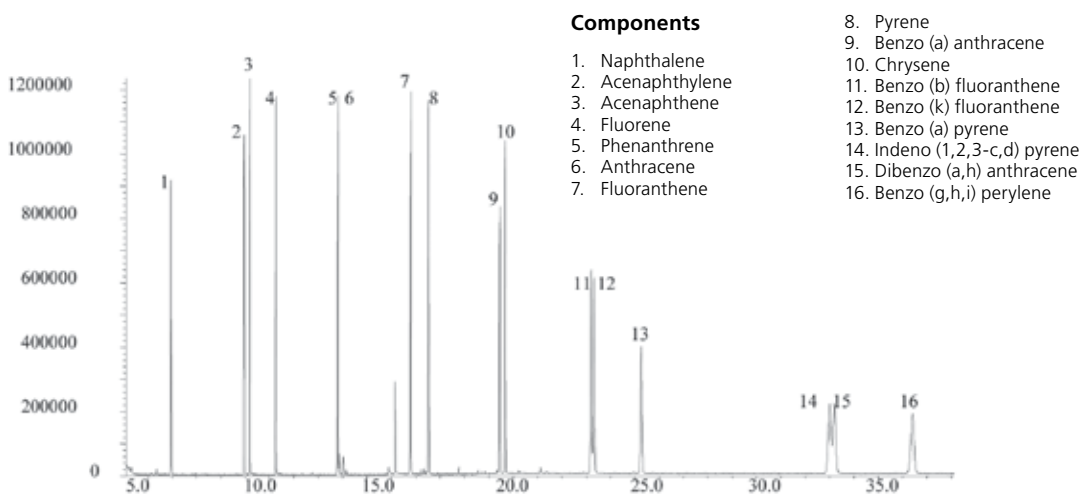

ARO 08 | Analysis of Polynuclear Aromatic Hydrocarbons on HT8

Column Part No.:	054462	Rate:	4 °C/min
Phase:	HT8, 0.25 µm film	Final Temp:	380 °C, 5 min
Column:	25 m x 0.22 mm ID	Carrier Gas:	He, 20 psi
Initial Temp:	150 °C, 1 min	Detector:	FID

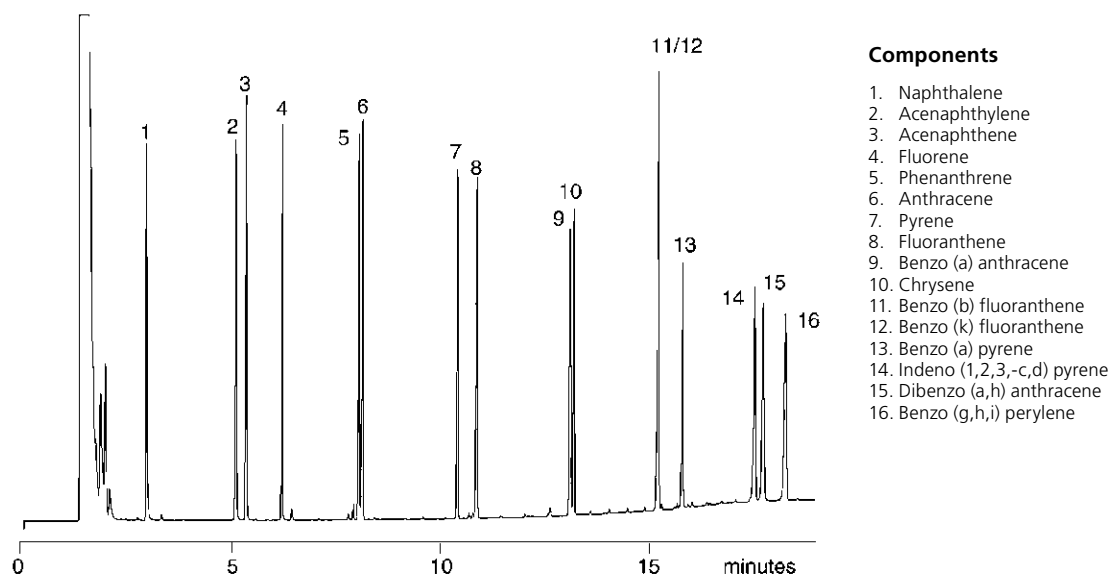

GC Columns and Applications

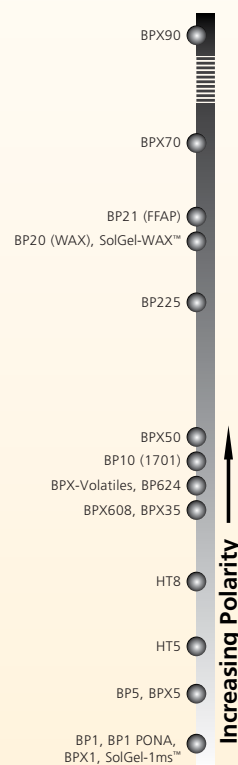



GC Columns and Applications

AP 0040C | HT8: The Perfect PCB Column

Separation of CB31 & CB28

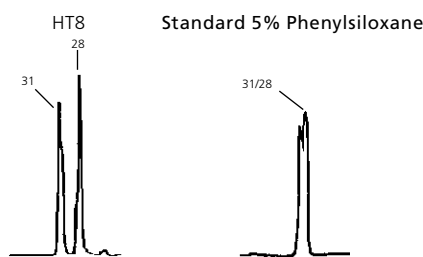

Chromatogram on the left clearly demonstrates the significant difference in selectivity of the HT8 column. By GC/MS, quantitation of CB28 using a standard 5% phenylpolysiloxane column is impossible as coelution with CB31 (with the same number of chlorines) occurs.

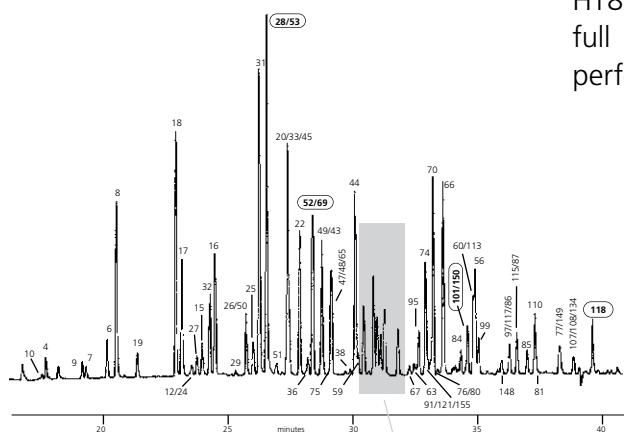

HT8 separates the two congeners by a full minute allowing quantitation to be performed with ease.

AROCLOR 1242

Column Part No.: 054676

Phase: HT8, 0.25 µm film

Column: 50 m x 0.22 mm ID

Initial Temp: 80 °C, 2 min

Rate 1: 30 °C/min

Temp 2: 170 °C

Rate 2: 3 °C/min

Final Temp: Split, 300 °C

Carrier Gas: He, 40 psi

Detector: ECD, 330 °C

Congener #	Cl Position	Cl #	Identification by GC/MS
42	23-24	4	✓
96	236-26	5	✓
35	34-3	3	✓
64	235-4	4	*
72	25-35	4	*
103	246-25	5	✓
71	26-34	4	✓
41	234-2	4	✓
68	24-35	4	✓
37	34-4	3	✓
100	246-24	5	✓

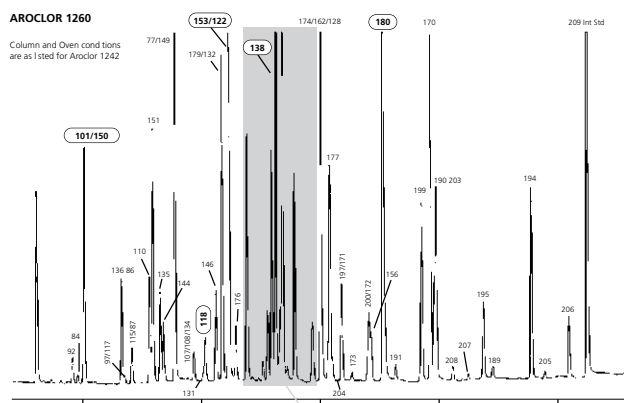

Congener #	Cl Position	Cl #	Identification by GC/MS
42	23-24	4	✓
96	236-26	5	✓
35	34-3	3	✓
64	235-4	4	*
72	25-35	4	*
103	246-25	5	✓
71	26-34	4	✓
41	234-2	4	✓
68	24-35	4	✓
37	34-4	3	✓
100	246-24	5	✓

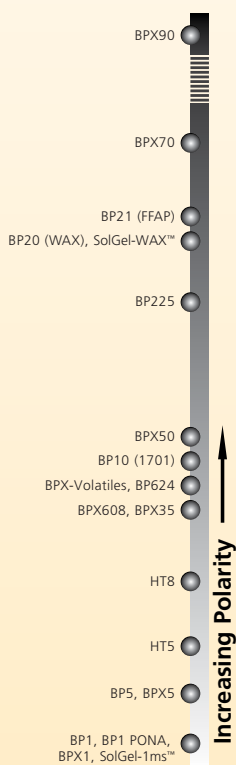
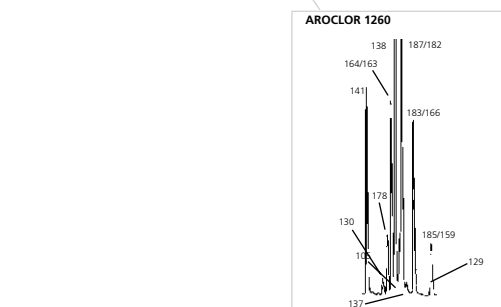

TP-0187-C | Analysis of Polynuclear Aromatic Hydrocarbons on BPX50

Column Part No.:	054701	Temperature Profile:	Hold 70 °C for 1 min
Phase:	BPX50, 0.25 µm film		70 °C to 140 °C at 25 °C/min
Column:	30 m x 25 µm ID		140 °C to 250 °C at 15 °C/min
Gas Flow:	1.5 ml/min Helium		250 °C to 310 °C at 4 °C/min
Injection:	Split 1 µl (1 ng on column)		Hold 310 °C for 8 min
Injection Temperature:	250°C		



GC Columns and Applications

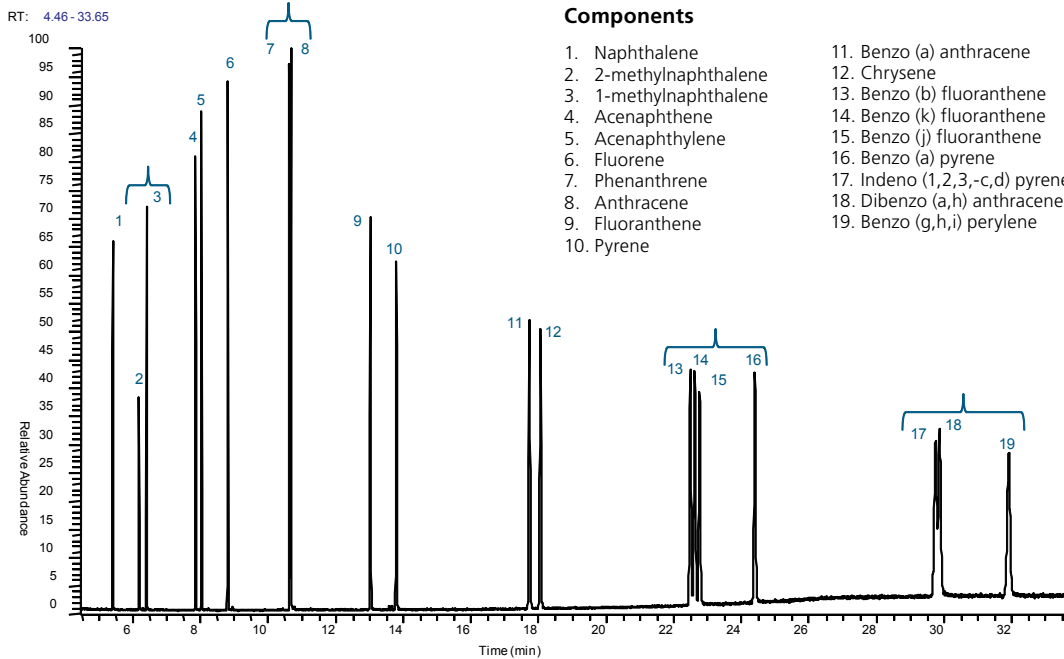

ENV 17 | Analysis of 16 Volatile Compounds in Drinking Water on BP624

Column Part No.:	054826	Final Temp.:	170 °C
Phase:	BP624, 1.2 µm	Detector:	HP5870 MSD
Column:	25 m x 0.22 mm ID	Injection Mode:	Splitless
Initial Temp.:	50 °C, 2 min	Carrier Gas:	He, 15 psi
Rate:	15 °C/min		

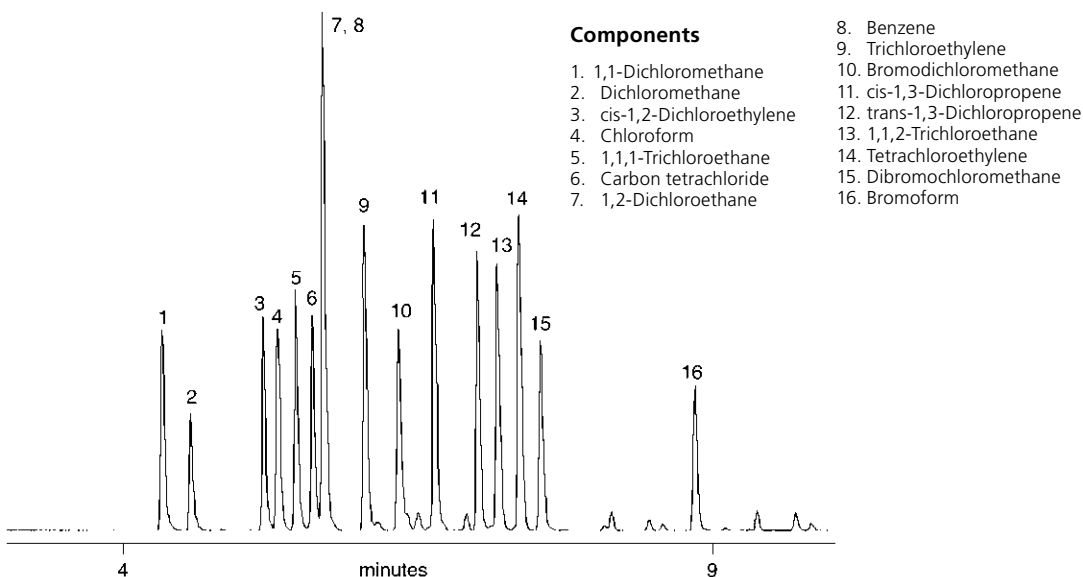



ENV 13 | Analysis of Volatiles from Drinking Water on BP624

Column Part No.:	054835		
Phase:	BP624, 3.0 µm	Rate 2:	15 °C/min
Column:	50 m x 0.53 mm ID	Final Temp.:	210 °C, 1 min
Initial Temp.:	35 °C, 2 min	Detector:	MSD, MJSC Jet Separator
Rate 1:	8 °C/min	Injection Mode:	Purge & Trap
Temp 2:	180 °C, 5 min	Carrier Gas:	He, 10 ml/min

Note: Column which provides fast analysis of all EPA compounds. BP624 is also ideal for the analysis of many commonly used solvents.

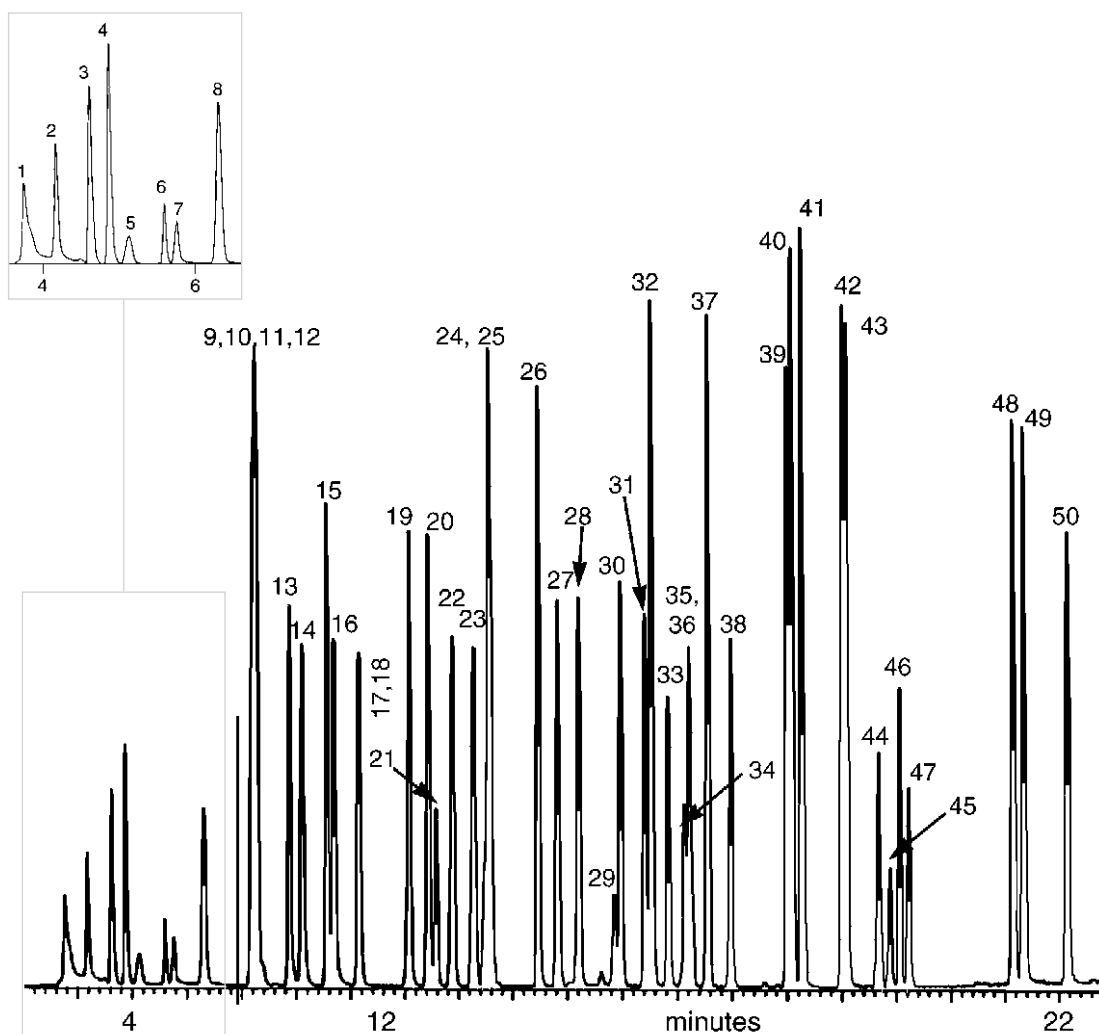

Components

1. Carbon dioxide
2. Dichlorodifluoromethane
3. Chloromethane
4. Vinyl chloride
5. Acetaldehyde
6. Bromomethane
7. Chloroethane
8. Trichlorofluoromethane
9. Trichlorofluoroethane
10. Acrolein
11. Acetone
12. 1,1-Dichloroethene
13. Carbon disulfide
14. Methylene chloride
15. trans-1,2-Dichloroethene
16. Acrylonitrile

17. 1,1-Dichloroethane
18. Vinyl acetate
19. 2-Butanone (MEK)
20. cis-1,2-Dichloroethene
21. Bromochloromethane (Int. Std.)
22. 1,1,1-Trichloroethane
23. Carbon tetrachloride
24. 1,2-Dichloroethane-d4 (Surrogate)
25. 1,2-Dichloroethane
26. Trichloroethene
27. 1,2-Dichloroethene
28. Bromodichloromethane
29. 4-Methyl-2-pentanone
30. cis-1,3-Dichloropropene
31. Toluene-(d8) (Surrogate)
32. Toluene
33. trans-1,3-Dichloropropene
34. 2-Bromo-1-chloropropane (Int.Std)

35. 1,1,2-Trichloroethane
36. 2-Hexanone
37. Tetrachloroethene
38. Dibromochloromethane
39. Chlorobenzene
40. Ethylbenzene
41. m,p-Xylene
42. o-Xylene
43. Styrene
44. Bromoform
45. 1,4-Dichlorobutane (Int. Std)
46. Bromofluorobenzene
47. 1,1,2,2- Tetrachloroethene
48. 1,3-Dichlorobenzene
49. 1,4-Dichlorobenzene
50. 1,2-Dichlorobenzene

TP-0102-C | Analysis of Volatile Organic Pollutants on a Volatiles GC Column



GC Columns and Applications

Column Part No.:	054979	Average Linear Velocity:	35 cm/sec at 40 °C
Phase:	BPX-Volatiles 1µm film	Injection Mode:	Split
USEPA 502.2 mix:	200 ppm in Methanol	Split Ratio:	50:1
Column:	40m x 0.18mm ID	Injection Volume:	1 µL
Initial Temp:	40 °C, 0 min.	Injection Temperature:	250 °C
Rate 1:	6 °C to 210 °C	Autosampler:	No
Rate 2:	15 °C to 250 °C	Liner Type:	4 mm ID Single Taper
Final Temp:	250 °C, 5 min	Liner Part Number:	092017
Detector Type:	Mass Spectrometer	Column Part Number:	054979
Carrier Gas:	He, 40.3 psi	ms-NoVent™ Part no.:	113400
Carrier Gas Flow:	1.2 µL/min.	HP5973 restrictor:	113409
Constant Flow:	On	Full scan	45-450

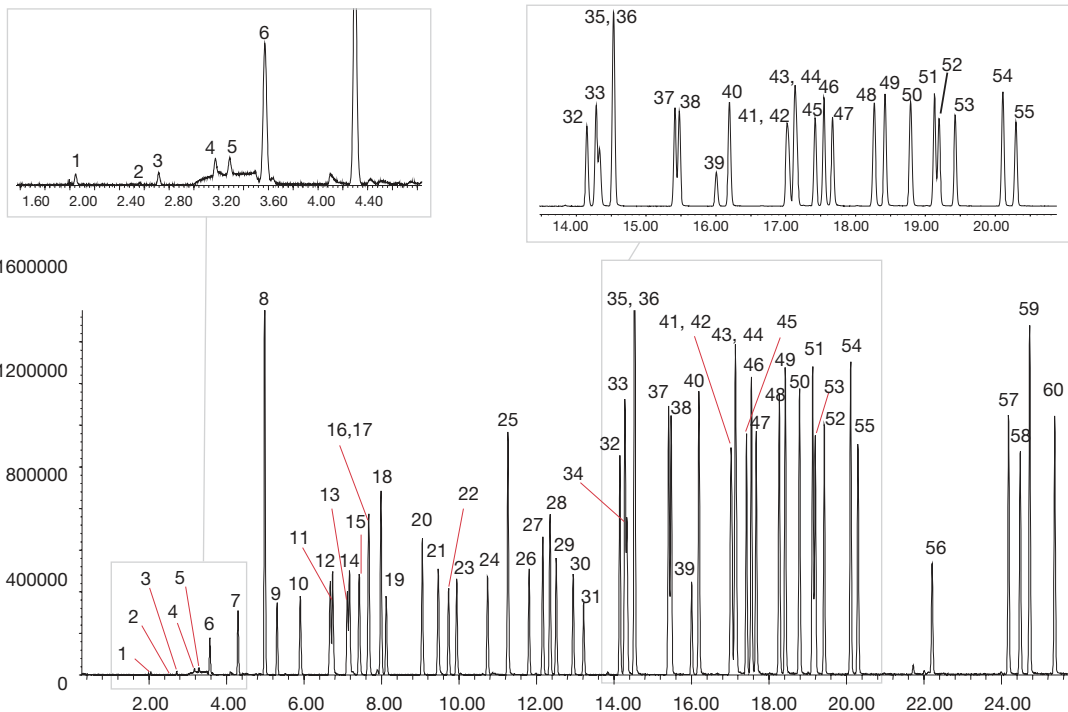

Notes. Chromatogram showing analysis of commonly screened volatile organic pollutants

Components

- | | | |
|-----------------------------|-------------------------------|---------------------------------|
| 1. Dichlorodifluoromethane | 20. Trichloroethene | 41. Bromobenzene |
| 2. Chloromethane | 21. 1,2-Dichloropropane | 42. 1,1,2,2-Tetrachloroethane |
| 3. Vinyl chloride | 22. Dibromomethane | 43. 1,2,3-Trichloropropane |
| 4. Bromomethane | 23. Bromodichloromethane | 44. n-Propyl benzene |
| 5. Chloroethane | 24. cis-1,3-Dichloropropene | 45. 2-Chlorotoluene |
| 6. Trichlorofluoromethane | 25. Toluene | 46. 1,3,5-Trimethylbenzene |
| 7. 1,1-Dichloroethene | 26. trans-1,3-Dichloropropene | 47. 4-Chlorotoluene |
| 8. Dichloromethane | 27. 1,1,2-Trichloroethane | 48. tert-Butylbenzene |
| 9. trans-1,2-Dichloroethene | 28. Tetrachloroethene | 49. 1,2,4-Trimethylbenzene |
| 10. 1,1-Dichloroethane | 29. 1,3-Dichloropropane | 50. sec-Butylbenzene |
| 11. 2,2-Dichloropropane | 30. Dibromochloromethane | 51. 1,3-Dichlorobenzene |
| 12. cis-1,2-Dichloroethene | 31. 1,2-Dibromoethane | 52. p-Isopropyltoluene |
| 13. Bromochloromethane | 32. Chlorobenzene | 53. 1,2-Dichlorobenzene |
| 14. Chloroform | 33. Ethylbenzene | 54. n-Butylbenzene |
| 15. 1,1,1-Trichloroethane | 34. 1,1,1,2-Tetrachloroethane | 55. 1,4-Dichlorobenzene |
| 16. 1,1-Dichloropropene | 35. p-Xylene | 56. 1,2-Dibromo-3-chloropropane |
| 17. Carbon tetrachloride | 36. m-Xylene | 57. 1,2,4-Trichlorobenzene |
| 18. Benzene | 37. o-Xylene | 58. Hexachlorobutadiene |
| 19. 1,2-Dichloroethane | 38. Styrene | 59. Naphthalene |
| | 39. Bromoform | 60. 1,2,3-Trichlorobenzene |
| | 40. Isopropylbenzene | |

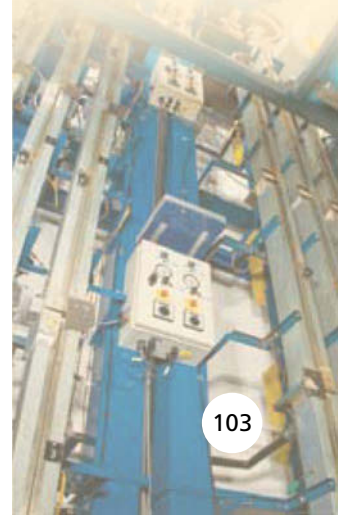



GC Columns and Applications

ENV 20 | Analysis of Polychlorinated p-Dibenzodioxins on BPX5

Column Part No.:	054114
Phase:	BPX5, 0.25 μm
Column:	50 m x 0.22 mm ID
Initial Temp.:	80 °C, 2 min
Rate 1:	4 °C/min
Temp 2:	220 °C
Rate 2:	5 °C/min

Temp. 3:	235 °C, 7 min
Rate 3:	5 °C/min
Final Temp.:	330 °C, 6 min
Detector:	High Resolution
Mass Spectrometer	He, 15 psi
Carrier Gas:	He, 300 psi
Injection Mode	Splitless, 270 °C

Hexachlorodibenzodioxins

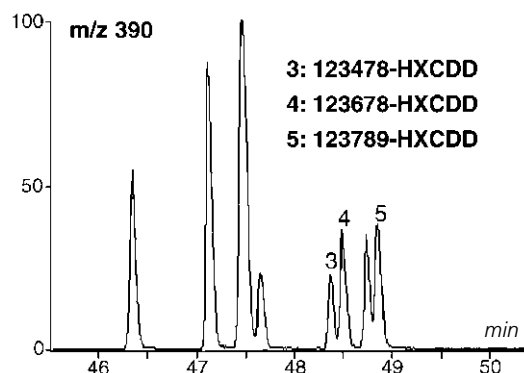

Tetrachlorodibenzodioxins

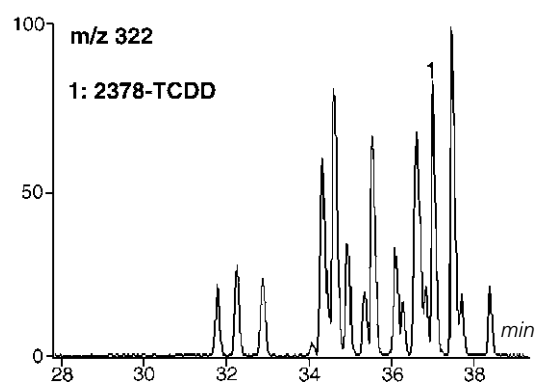

Heptachlorodibenzodioxins

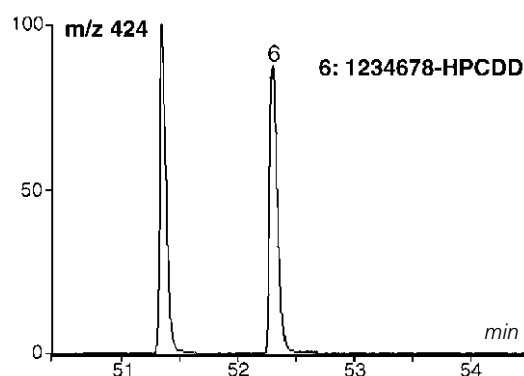

Pentachlorodibenzodioxins

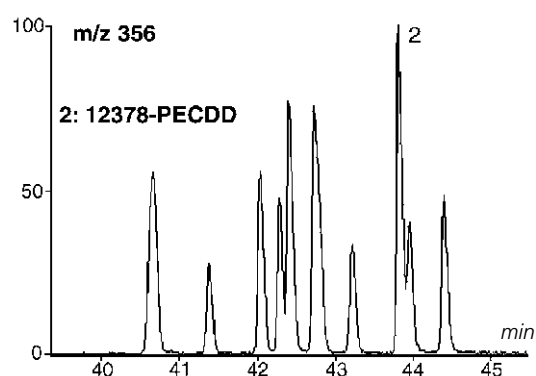

Octachlorodibenzodioxin

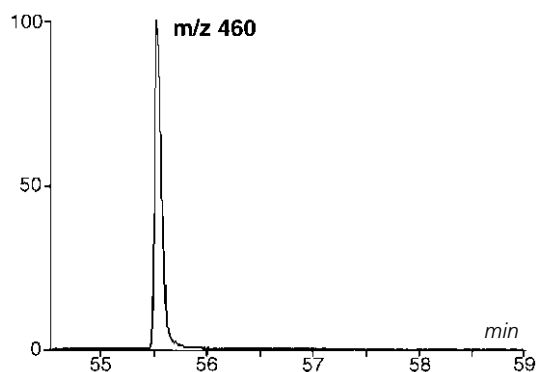

SGE wishes to acknowledge CARSO, 321 Avenue Jean Jaures, 69362 LYON CEDEX 7, FRANCE

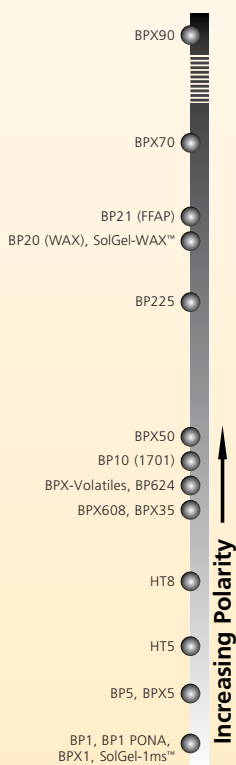

ENV 57 | 8081 Organochlorine Pesticide Mix on BPX35

Column Part No.:	054701		
Phase:	BPX35 0.25 µm film	Constant Flow:	On
Column:	30 m x 0.25 mm ID	Average Linear Velocity:	36 cm/sec at 40 °C
8081 Standard:	10 ng/ µL in dichloromethane	Injection Mode:	Splitless
Initial Temp.:	40 °C, 1 min.	Purge on Time:	1 min.
Rate 1:	30 °C to 190 °C, 3 min	Purge on (Split) Vent Flow:	60 mL/min.
Rate 2:	10 °C to 300 °C	Injection Volume:	1 µL
Final Temp.:	300 °C, 5 min.	Injection Temp.:	250 °C
Detector Type:	MSD	Autosampler:	No
Carrier Gas:	He, 10.0 psi	Liner Type:	4 mm ID Double Taper Liner
Carrier Gas Flow:	1.3 mL/min	Liner Part Number:	092018



GC Columns and Applications

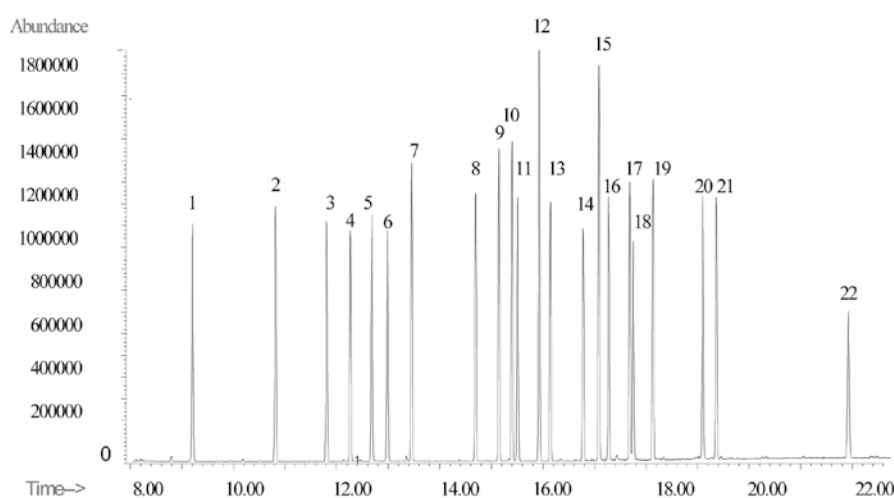

Components

1. 2,4,5,6-tetrachloro-meta-xylene
2. α-BHC
3. γ-BHC
4. β-BHC
5. Heptachlor
6. δ-BHC
7. Aldrin
8. Heptachlorepoxy
9. trans-Chlordane
10. cis-Chlordane
11. Endosulfan A
12. DDE
13. Dieldrin
14. Endrin
15. DDD
16. Endosulfan B
17. DDT
18. Endrin Aldehyde
19. Endosulfan Sulfate
20. Methoxychlor
21. Endrin Ketone
22. Decachlorobiphenyl

ENV 03 | Analysis of 18 Chlorinated Pesticides on BPX5

Part No.:	054125		
Phase:	BPX5, 0.5 µm film	Final Temp.:	290 °C, 5 min
Column:	25 m x 0.32 mm ID	Detector:	ECD at 310 °C
Initial Temp.:	170 °C	Injection Mode:	Split
Rate:	7 °C	Carrier Gas:	He, 7 psi

Notes: Combined with the BPX608 column, BPX5 is the perfect confirmation column.

Components

20ng/ µL each component

1. α-BHC
2. γ-BHC
3. β-BHC
4. Heptachlor
5. δ-BHC
6. Aldrin
7. Heptachlorepoxy (isomer B)
8. Endosulfan I
9. 4,4'-DDE
10. Dieldrin
11. Endrin
12. 4,4'-DDD
13. Endosulfan II
14. 4,4'-DDT
15. Endrin aldehyde
16. Endosulfan sulfate
17. Methoxychlor
18. Endrin ketone

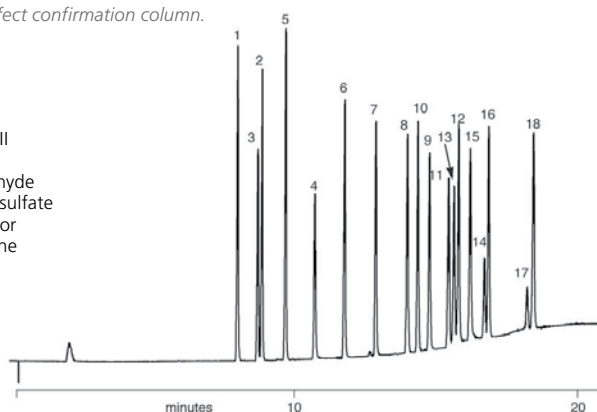



GC Columns and Applications

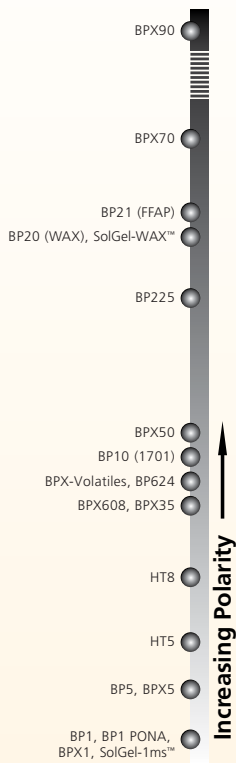

ENV 59 | 8141 Organophosphorous Pesticide Mix on BPX5

Column Part No.:	054101	Constant Flow:	On
Phase:	BPX5 0.25 µm film	Average Linear Velocity:	42 cm/sec at 50 °C
Column:	30 m x 0.25 mm ID	Injection Mode:	Splitless
8141 Standard:	10 ng/ µL in dichloromethane	Purge on Time:	0.5 min
Initial Temp.:	50 °C, 1 min	Purge on (Split) Vent Flow:	60 mL/min
Rate 1:	30 °C/min to 190 °C, 3 min	Injection Volume:	1 µL
Rate 2:	10 °C/min to 300 °C	Injection Temperature:	250 °C
Final Temp.:	300 °C, 5 min.	Autosampler:	No
Detector Type:	MSD	Liner Type:	4 mm ID Double Taper Liner
Carrier Gas:	He, 11.1 psi	Liner Part Number:	092018
Carrier Gas Flow:	1.3 mL/min		

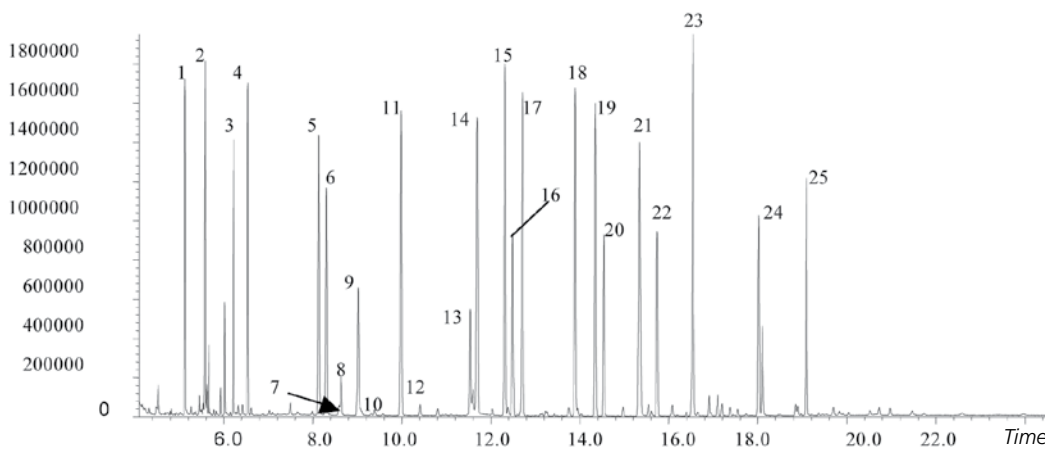

Components

- | | | |
|-------------------------------------|----------------------|------------------------|
| 1. 4-Chloro-3-nitrobenzotrifluoride | 8. Naled | 17. Trichlorinate |
| 2. Dichlorvos | 9. Phorate | 18. Tetrachlorvinphos |
| 3. 1-Bromo-2-nitrobenzene | 10. Demeton | 19. Tokuthion |
| 4. α-Mevinphos | 11. Diazinon | 20. Impurity |
| 5. Tri-butylphosphate | 12. Disulfoton | 21. Fensulfothion |
| 6. Ethoprop | 13. Methyl parathion | 22. Impurity |
| 7. Sulfotepp | 14. Ronnel | 23. Triphenylphosphate |
| | 15. Chlorpyrifos | 24. Guthion |
| | 16. Fenthion | 25. Coumaphos |

ENV 45 | Organophosphorous Pesticides on BPX50



GC Columns and Applications

Column Part No.:	054751
Phase:	BPX50, 0.25 µm film
Mixture of:	10 ng/ µL
Organophosphorous Pesticides:	10 ng/ µL in
Column:	30 m x 0.25 mm ID
Initial Temp:	50 °C , 1 min
Rate 1:	30 °C/min to 200 °C, 3 min
Rate 2:	10 °C/min to 310 °C
Final Temp:	310 °C, 2 min
Detector Type:	FID, 320 °C
Carrier Gas:	He, 14.4 psi
Carrier Gas Flow:	1.30 mL/min
Constant Flow:	On
Average Linear Velocity:	30 cm/sec at 50 °C
Injection Mode:	Splitless
Purge On Time:	0.5 min
Purge On (Split) Vent Flow:	60 mL/min
Injection Volume:	1.0 µL
Injection Temperature:	240 °C
Autosampler:	Yes
Liner Type:	4 mm ID FocusLiner™ with single taper
Liner Part Number:	092003

Column Part Number:	054740
Phase:	BPX50, 0.10 µm film
Mixture of 10 ng/ µL	42 cm/sec at 50 °C
Organophosphorous Pesticides	Splitless
Column:	10 m x 0.10 mm ID
Initial Temp.:	70 °C , 1 min
Rate 1:	25 °C/min to 320 °C
Rate 2:	N/A
Final Temp:	320 °C, 0 min
Detector Type:	FID, 320 °C
Carrier Gas:	He, 39.0 psi
Carrier Gas Flow :	0.370 mL/min
Constant Flow:	On
Average Linear Velocity:	35 cm/sec at 70 °C
Injection Mode:	Split
Purge On Time:	1.0
Purge On (Split) Vent Flow:	10 mL/min
Injection Volume:	0.5 µL
Injection Temperature:	240 °C
Autosampler:	Yes
Liner Type :	2.3 mm ID FocusLiner™
Liner Part Number:	092005

NORMAL

Chromatogram showing separation of Organophosphorous Pesticides using a conventional 30 meter x 0.25 mm ID BPX50 column with a 0.25 micron film.

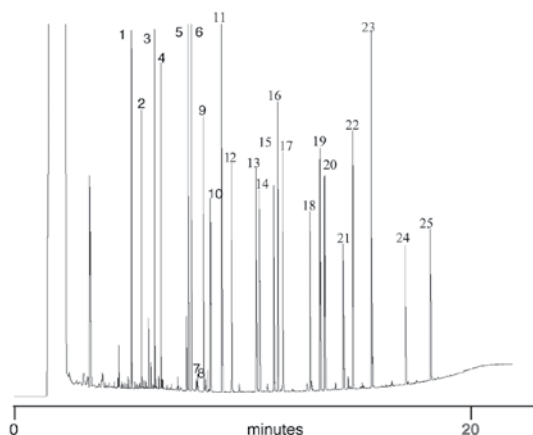

Components

- | | |
|--------------------------------------|----------------------|
| 1. 4-Chloro-3-nitrobenzo-trifluoride | 8. Naled |
| 2. Dichlorvos | 9. Phorate |
| 3. 1-Bromo-2-nitrobenzene | 10. Demeton |
| 4. α-Mervinphos | 11. Diazinon |
| 5. Tributylphosphate (IS) | 12. Disulfoton |
| 6. Ethoprop | 13. Methyl Parathion |
| 7. Sulfotepp | 14. Ronnel |
| | 15. Chlorpyrifos |
| | 16. Fenthion |

FAST

Chromatogram showing separation of Organophosphorous Pesticides using a **FAST BPX50** column.

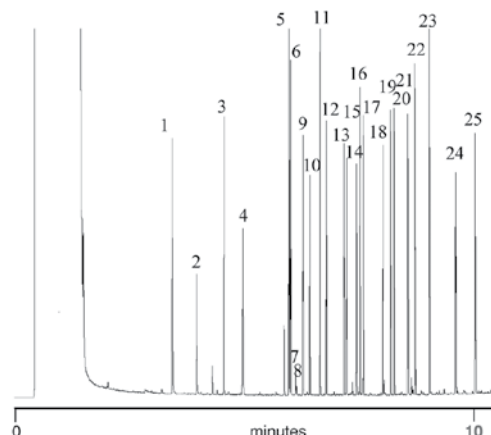

- | |
|-----------------------------|
| 17. Trichlorinate |
| 18. Tetrachlorvinphos |
| 19. Tokuthion |
| 20. Impurity |
| 21. Fensulfothion |
| 22. Impurity |
| 23. Triphenylphosphate (IS) |
| 24. Guthion |
| 25. Coumaphos |





GC Columns and Applications

ENV 04 | Analysis of Herbicides on BPX35

Column Part No.:	054711		
Phase:	BPX35, 0.25 µm film	Final Temp.:	300 °C 5 min
Column:	25 m x 0.22 mm ID	Detector:	FID, 380 °C
Initial Temp.:	80 °C	Injection Mode:	Split (20:1)
Rate:	10 °C/min	Carrier Gas:	He, 100 kpa

Note: BPX35 provides quick analysis of all 3 Triazine compounds

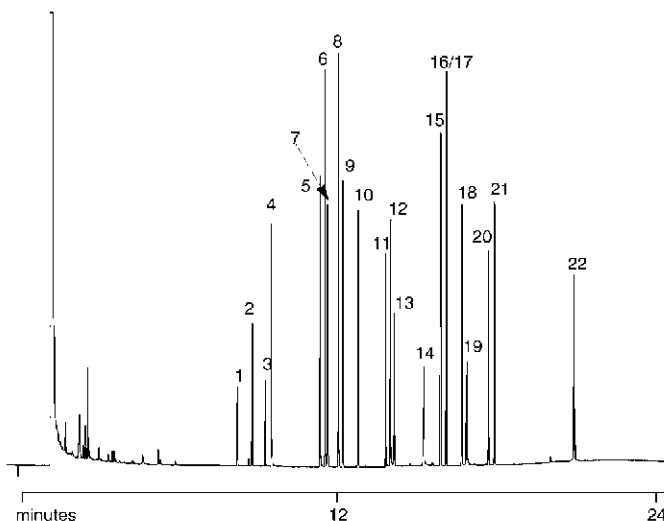

Components

1. Eptam®
2. Sutan®
3. Vernam®
4. Tillam®
5. Ordram®
6. Treflan®
7. Balan®
8. Ro-Neet®
9. Propachlor
10. Tolban®
11. Propazine
12. Atrazine
13. Simazine
14. Terbacil
15. Sencor®
16. Dual®
17. Paarlan®
18. Prowl®
19. Bromacil
20. Oxadiazon
21. GOAL®
22. Hexazinone

ENV 48 | Analysis of Herbicides on BPX5

Column Part No.:	054101		
Phase:	BPX5, 0.25 µm	Rate 2:	5 °C/min
Column:	30 m x 0.25 mm ID	Final Temp.:	260 °C, 10 min
Initial Temp.:	90 °C, 1 min	Detector:	NPD
Rate 1:	30 °C/min	Injection Mode:	Varian SPI
Temp.:	180 °C	Carrier Gas:	He, 10 psi

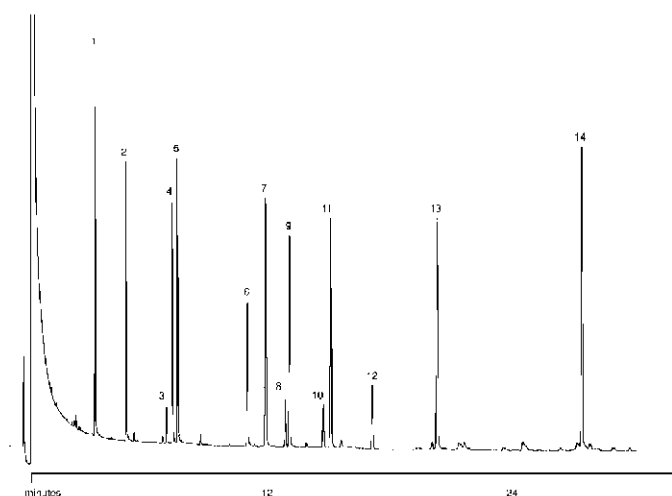

Components

1. Metamidofos
2. Acephate
3. Diphenylamine
4. Monocrofos
5. Sulfotep
6. Tolclofos-methyl
7. Fenitrothion
8. Triadimefon
9. Trichloronate
10. Triadimenol
11. Bromophos-ethyl
12. Bupirimate
13. Carbofenthothion
14. Dialifos

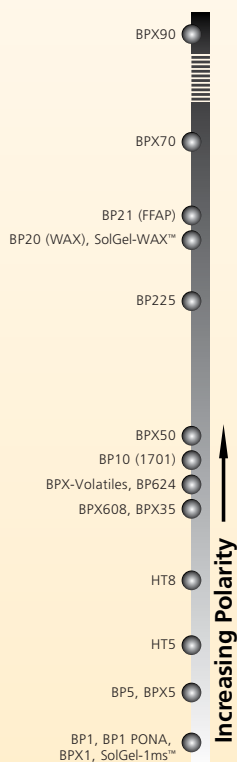

ARO 14 | Analysis of chlorinated and nitroaromatic compounds on SolGel-1ms™



GC Columns and Applications

Column Part No.:	054462	Constant Flow:	On
Phase:	SolGel-1ms™ 0.25 µm film	Average Linear Velocity:	35 cm/sec, 40 °C
Sample:	200 ppm in dichloromethane	Injection Mode:	Split
Column:	30 m x 0.25 mm ID	Split Ratio:	100 : 1
Initial Temp:	40 °C, 1 min.	Injection Volume:	0.5 µL
Rate 1:	10 °C/min to 300 °C	Injection Tem:	250 °C
Final Temp:	300 °C, 2 min.	Liner Type:	4 mm ID Single Taper Liner
Detector Type:	MSD	Liner Part No.:	092017
Carrier Gas:	He, 25.7 psi	Full Scan / SIM:	Full scan 45-450
Carrier Gas Flow:	1.8 mL/min.		

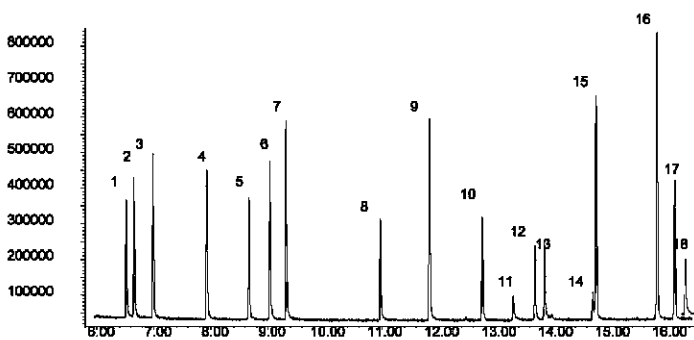

Components

1. Phenol
2. o-Chlorophenol
3. p-Dichlorobenzene
4. Nitrobenzene
5. o-Nitrophenol
6. 2,4-Xylenol
7. 2,4-Dichlorophenol
8. 4-Chloro-3-methylphenol
9. 2,4,6-Trichlorophenol
10. 2,6-Dinitrotoluene
11. 2,4-Dinitrophenol
12. 2,4-Dinitrotoluene
13. 4-Nitrophenol
14. 4,6-Dinitro-o-cresol
15. 4-Chlorophenyl phenyl ether
16. 4-Bromophenyl phenyl ether
17. Hexachlorobenzene
18. Pentachlorophenol

ALC 06 | US EPA 625 Phenols Mix on BPX50

Column Part No.:	054751	Initial Oven Temp:	50 °C, 1 min
Phase:	BPX50, 0.25 µm	Rate 1:	8 °C/min
Column:	30 m x 0.25 mm ID	Final Temp:	300 °C, 10 min
Injector Mode:	Split, 40:1	Detector:	HP 5973 MSD

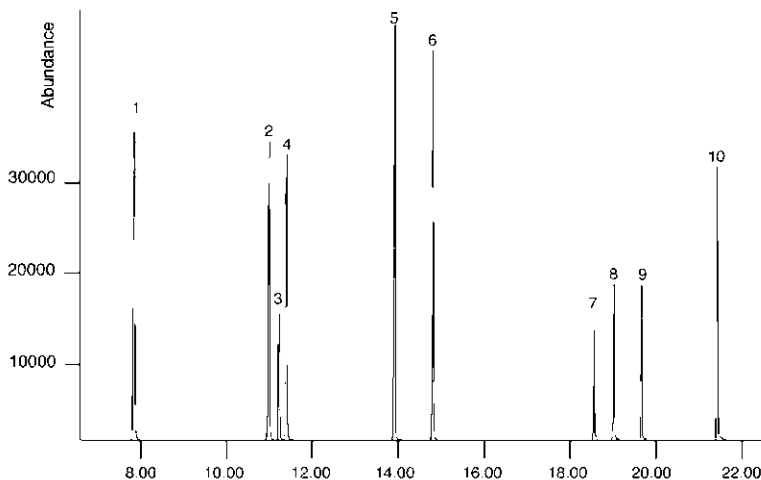

Components

1. 2-Chlorophenol
2. 2-Nitrophenol
3. 2, 4-Dimethylphenol
4. 2, 4-Dichlorophenol
5. 4-Chloro-3-methylphenol
6. 2, 4, 6-Trichlorophenol
7. 2, 4- Dinitrophenol
8. 4-Nitrophenol
9. 2-Methyl-4, 6-dinitrophenol
10. Pentachlorophenol





GC Columns and Applications

ENV 65 | Analysis of Synthetic Pyrethroids on BPX50

Column Part No.:	054751		
Phase:	BPX50, 0.25 µm film	Constant Flow:	On
Column:	30 m x 0.25 mm ID 16	Average Linear Velocity:	36 cm/sec at 50 °C
Pyrethroids:	10 ppm in methanol	Injection Mode:	Splitless
Initial Temp.:	50 °C, 1 min.	Purge on Time:	0.5 min
Rate 1:	30 °C/min to 200 °C	Purge on (Split) Vent Flow:	60 mL/min
Rate 2:	4 °C/min to 300 °C	Injection Volume:	1 µL
Final Temp.:	300 °C, 5 min	Injection Temperature:	250 °C
Detector Type:	MSD	Autosampler:	No
Carrier Gas:	He, 6.8 psi	Liner Type:	4 mm ID Double Taper Liner
Carrier Gas Flow:	1.0 mL/min	Liner Part Number:	092018

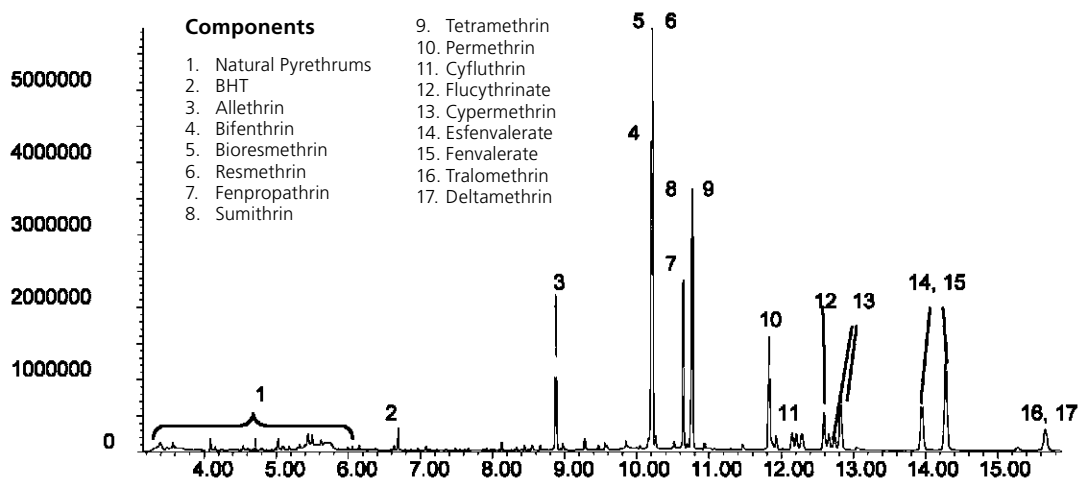

ARO 13 | Analysis of BTEX on SolGel-WAX™

Column Part No.:	054796		
Phase:	SolGel-WAX™ 0.25 µm film	Constant Flow:	On
BTEX:	300 ppm in methanol	Average Linear Velocity:	35 cm/sec, 60 °C
Column:	30 m x 0.25 mm ID	Injection Mode:	Split
Initial Temp:	60 °C, 10 min	Split Ratio:	100:1
Detector Type:	FID	Injection Volume:	0.2 µL
Carrier Gas:	He, 17.3 psi	Injection Temp:	250 °C
Carrier Gas Flow:	1.5 mL/min	Liner Type:	4 mm ID Double Taper Line
		Liner Part Number:	092018

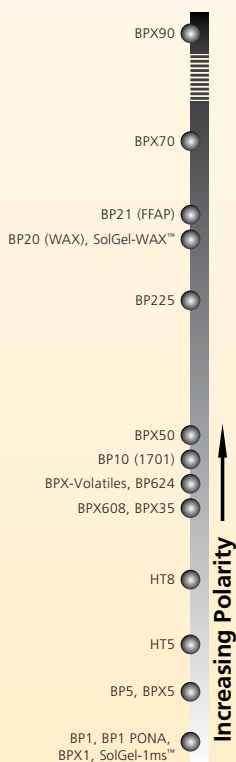
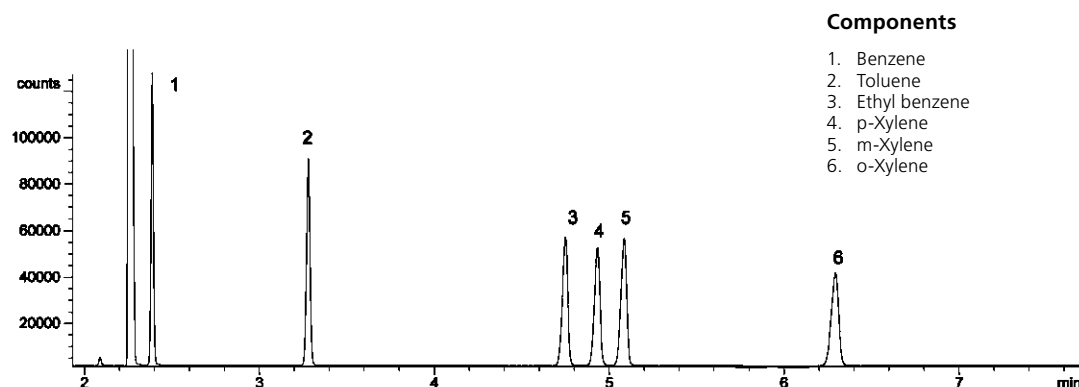



Column Part No.:	054101		
Phase:	BPX5, 0.25 µm film	Carrier Gas Flow:	1.1 mL/min.
Column:	30 m x 0.25 mm	Constant Flow:	On
ID Sample:	5 ppm solution	Injection Mode:	Splitless
Initial Temp.:	40 °C, 3 min	Purge on Time:	0.5 min
Rate 1:	8 °C/min to 300 °C	Purge on (Split) Vent Flow:	40 mL/min
Final Temp.:	300 °C, 9 min.	Injection Volume:	1 µL
Detector Type:	Mass Spectrometer	Injection Temperature:	250 °C
Carrier Gas:	He	Autosampler:	No
Inlet Pressure:	16 psi for 30 sec then drops to 10 psi	Liner Type:	4 mm ID Single Gooseneck
Pressure rate1:	10 psi to 28 psi at 0.5 psi/min	Liner Part Number:	092017
Final Pressure:	28 psi until end of run	Full Scan / SIM:	Full scan 41-450

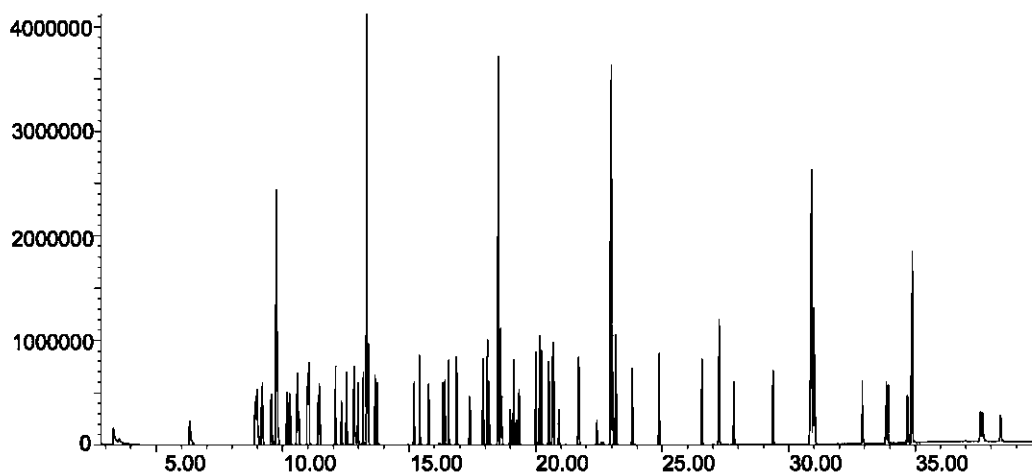

Components

- | | | |
|-----------------------------------|---------------------------------|----------------------------------|
| 1. Pyridine | 28. Naphthalene-d8 | 57. 2,4,6-Tribromophenol |
| 2. n-Nitrosodimethylamine | 29. Naphthalene | 58. 4-Bromophenyl phenyl ether |
| 3. 2-Fluorophenol | 30. Hexachlorobutadiene | 59. Hexachlorobenzene |
| 4. Phenol-d5 | 31. 4-Chloroaniline | 60. Pentachlorophenol |
| 5. Phenol | 32. 4-Chloro-3-methylphenol | 61. Phenanthrene-d10 |
| 6. Aniline | 33. 2-Methylnaphthalene | 62. Phenanthrene |
| 7. 2-Chlorophenol | 34. Hexachlorocyclopentadiene | 63. Anthracene |
| 8. bis- (2-chloroethyl) ether | 35. 2,4,6-Trichlorophenol | 64. Carbazole |
| 9. 1,3-Dichlorobenzene | 36. 2,4,5-Trichlorophenol | 65. Di-n-butyl phthalate |
| 10. 1,4-Dichlorobenzene-d4 | 37. 2-Fluorobiphenyl | 66. Fluoranthene |
| 11. 1,4-Dichlorobenzene | 38. 2-Chloronaphthalene | 67. Benzidine |
| 12. 1,2-Dichlorobenzene | 39. 2-Nitroaniline | 68. Pyrene |
| 13. Benzyl alcohol | 40. Dimethyl phthalate | 69. p-Terphenyl-d14 |
| 14. 2-Methyl phenol | 41. Acenaphthylene | 70. Butyl benzyl phthalate |
| 15. bis-(2-chloroisopropyl)ether | 42. 2,6-Dinitrotoluene | 71. Benz[a]anthracene |
| 16. n-Nitroso-di-n-propylamine | 43. Acenaphthene-d10 | 72. Chrysene-d12 |
| 17. Hexachloroethane | 44. Acenaphthene | 73. Chrysene |
| 18. 4-Methylphenol | 45. 3-Nitroaniline | 74. 3,3-Dichlorobenzidine |
| 19. Nitrobenzene-d5 | 46. 2,4-Dinitrophenol | 75. bis (2-Ethylhexyl) phthalate |
| 20. Nitrobenzene | 47. Dibenzofuran | 76. Di-n-octyl phthalate |
| 21. Isophorone | 48. 4-Nitrophenol | 77. Benzo (b) fluoranthene |
| 22. 2-Nitrophenol | 49. 2,4-Dinitrotoluene | 78. Benzo (k) fluoranthene |
| 23. 2,4-Xylenol | 50. Diethylphthalate | 79. Benzo (a) pyrene |
| 24. bis- (2-Chloroethoxy) methane | 51. Fluorene | 80. Perylene-d12 |
| 25. Benzoic acid | 52. 4-Chlorophenyl phenyl ether | 81. Indeno (1,2,3-cd) perylene |
| 26. 2,4-Dichlorophenol | 53. 2-Methyl-4,6-dinitrophenol | 82. Dibenz (a,h) anthracene |
| 27. 1,2,4-Trichlorobenzene | 54. 4-Nitroaniline | 83. Benzo[g,h,i]perylene |
| | 55. n-Nitrosodiphenylamine | |
| | 56. Azobenzene | |





GC Columns and Applications

ENV 84 continued

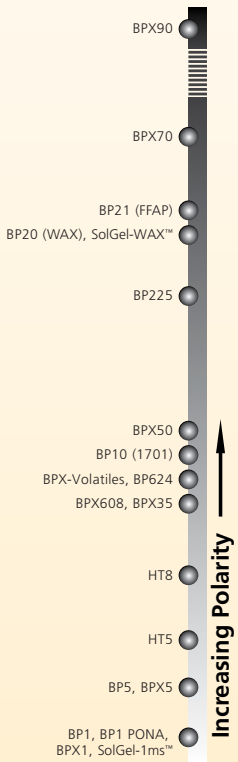
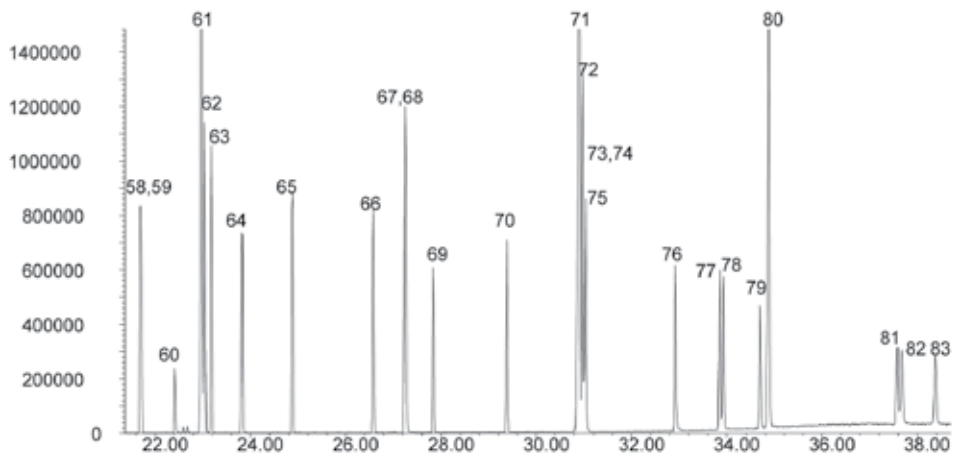
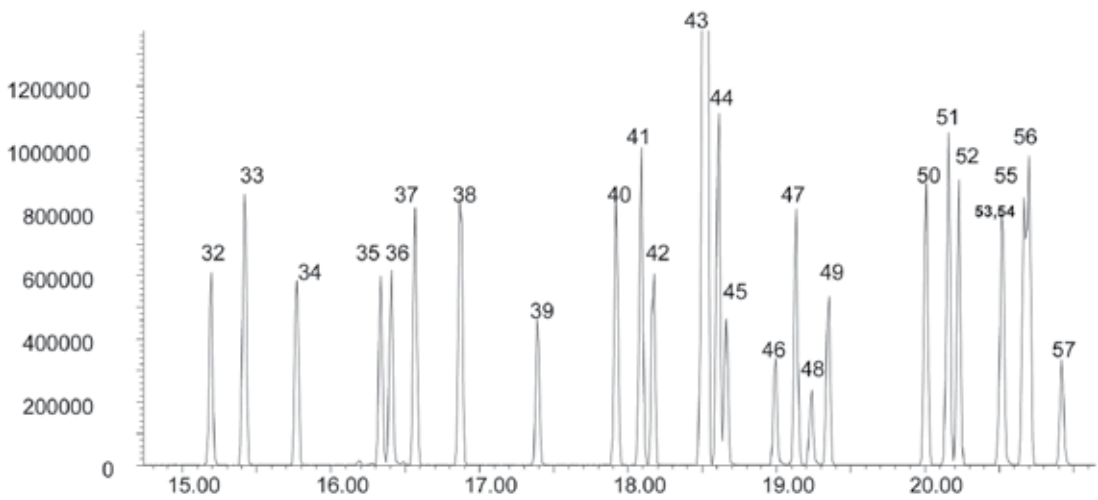
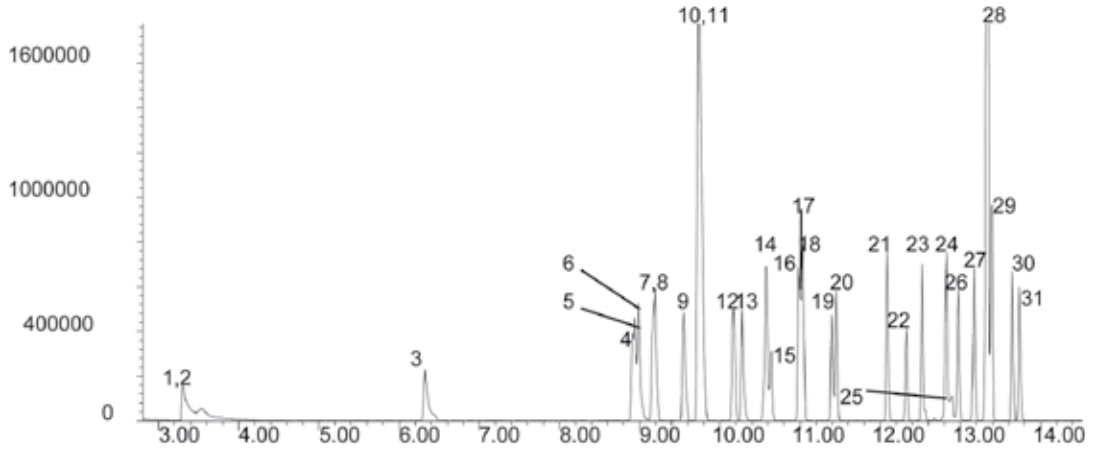

SGE would like to thank Mark Ferry from ECS/MDL USA for supplying all of the chromatograms for this application note.

FOO 03 | Analysis of Scotch Whisky on BP20

Column Part No.:	054447
Phase:	BP20, 1.0 µm film
Column:	12 m x 0.53 mm ID
Initial Temp:	55 °C, 3 min
Rate:	10 °C/min
Final Temp:	120 °C, 0 min
Detector:	FID
Sensitivity:	128 x 10 ⁻¹² AFS
Injection Mode:	Split

Components

1. Acetaldehyde
2. Ethyl Acetate
3. Methanol
4. Ethanol
5. Propan-1-ol
6. 2-Methylpropan-1-ol
7. 2-Methylbutan-1-ol + 3-Methylbutan-1-ol

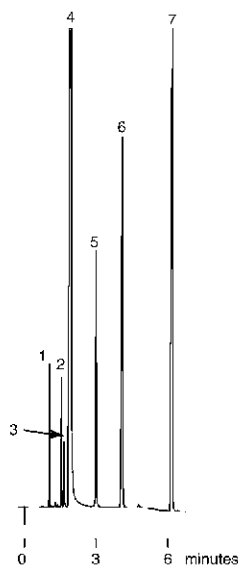

GC Columns and Applications

AN-0022-C | FAME Analysis with BPX90 – A Highly Polar Column

Column Part No.:	054570	Constant Flow:	ON
Phase:	90% Cyanopropyl Polysilphenylsiloxane	Pressure:	4.02 psi
Column Dimensions:	15 m x 0.25 mm x 0.25 µm	Column Flow Rate:	1.3 ml/min
Injector Temperature:	250 °C	Linear Velocity:	59 cm/sec
Injection Volume:	1.0 µL	Initial Temp.:	70 °C hold for 1 minute
Injector Type:	Split	Rate:	20 °C/min to 150 °C
Split Ratio:	100:1	Rate:	10 °C/min
Liner Type:	FocusLiner™	Final Temp.:	250 °C hold for 5 minutes
Carrier Gas:	Helium	Detector Type:	MSD

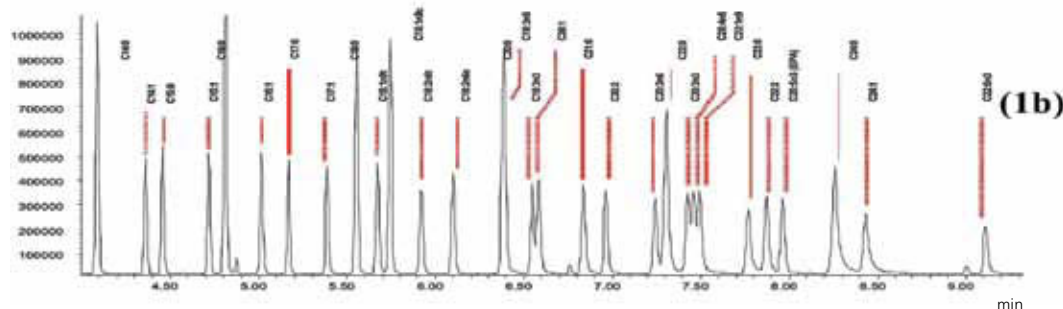
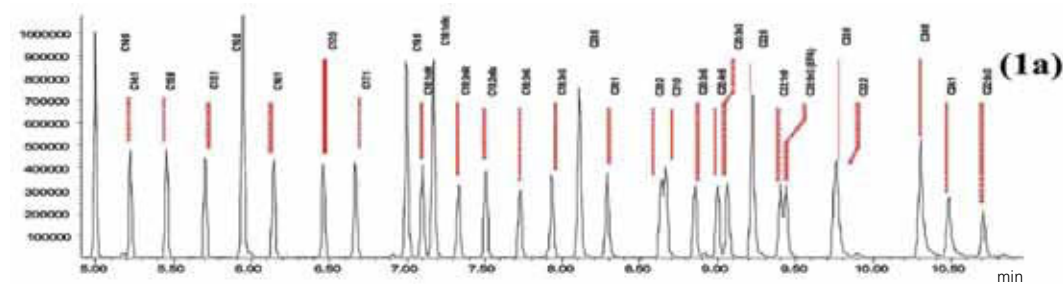

Supelco 37 FAME standard analyzed with (a) BPX70 and (b) BPX90

SGE would like to thank J. Harynyk, P.J. Marriott and P. Wynne, *Chromatographia*, 2006; 63 (Supplement 13): S61-S66.





GC Columns and Applications

AN-0011-C | Analysis of Omega-3 Fatty Acids using a Highly Selective GC Capillary Column

Column Part No.:	054606
Phase:	BPX70, 0.25 µm film
Sample:	10 ppm in methanol
Column:	25 m x 0.32 mm ID
Initial Temp:	80 °C, 2 min
Rate 1:	50 °C/min to 130 °C, 10 min
Rate 2:	2 °C/min to 172 °C
Final Temp:	172 °C, 6 min
Detector Type:	FID
Detector Temp:	300 °C
Carrier Gas:	He, 10 psi

Carrier Gas Flow:	2.2 mL/min
Constant Flow:	On
Average Linear Velocity:	39 cm/sec at 80 °C
Injection Mode:	Split
Split Ratio:	58:1
Injection Volume:	1 µL
Injection Temperature:	250 °C
Autosampler:	No
Liner Type:	4 mm ID FocusLiner™
Liner Part No.:	092002

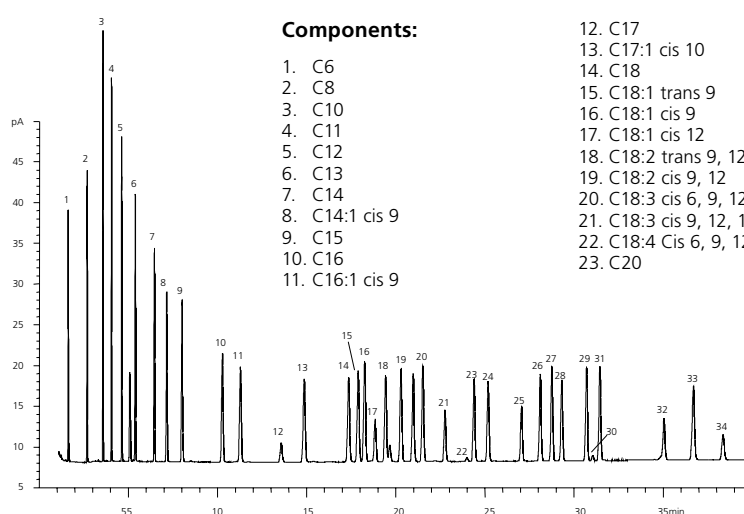
**Components:**

1. C6
2. C8
3. C10
4. C11
5. C12
6. C13
7. C14
8. C14:1 cis 9
9. C15
10. C16
11. C16:1 cis 9

12. C17
13. C17:1 cis 10
14. C18
15. C18:1 trans 9
16. C18:1 cis 9
17. C18:1 cis 12
18. C18:2 trans 9, 12
19. C18:2 cis 9, 12
20. C18:3 cis 6, 9, 12
21. C18:3 cis 9, 12, 15
22. C18:4 Cis 6, 9, 12, 15
23. C20

24. C21:1 cis 11
25. C20:2 cis 11,14
26. C20:3 cis 8, 11,14
27. C20:4 cis 5, 8, 11, 14
28. C20:3 cis 11, 14, 17
29. C22
30. C20:5 cis 5, 8, 11, 14, 17
31. C22:1 cis 13
32. C22:4 cis 7, 10, 13, 16
33. C24
34. C22:6 cis 4,7,10,13,16,19

Notes: The chromatogram shows the excellent separation of a complex mixture of FAME compounds. Note the excellent peak shape and separation of the Omega-1,2 and 3 fatty acid isomers both structural and cis and trans.

SGE would like to thank Masterfoods UK for supplying the sample and chromatographic conditions for this chromatogram.

FOO 16 | Analysis of Triglyceride Standards on HT5

Column Part No.:	054661
Phase:	HT5, 0.1 µm
Column:	6 m x 0.53 mm I.D. (Aluminum Clad)
Initial Temp.:	60 °C, 0 min
Program Rate:	10 °C/min
Final Temp.:	370 °C, 5 min
Carrier Gas:	H ₂ , 2 psi
Detector:	F.I.D.
Sensitivity:	32 x 10 ⁻¹² AFS
Injection Mode:	On-column

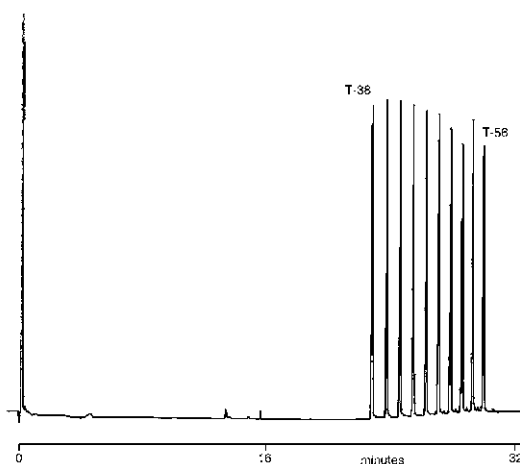

Notes: For the analysis of triglycerides, on-column injection is recommended. Temperatures above 380 °C are not recommended as triglycerides can degrade.

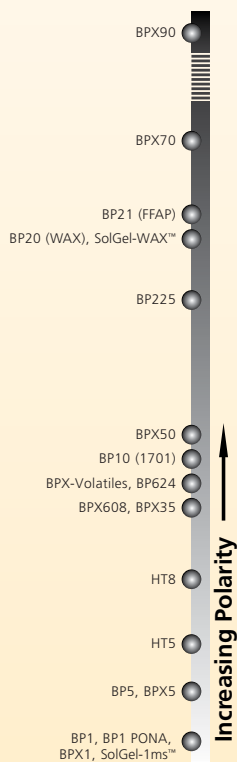

FLA 05 | Analysis of Menthol Oil on CYDEX-B

Column Part No.:	054901	Final Temp.:	130 °C
Phase:	Cydex-B, 0.25 µm film	Carrier Gas:	H ₂
Column:	50 m x 0.22 mm I.D.	Detector:	F.I.D.
Initial Temp.:	100 °C, 5 min	Sensitivity:	32 x 10-12 AFS
Rate:	2 °C/min	Injection Mode:	Split



GC Columns and Applications

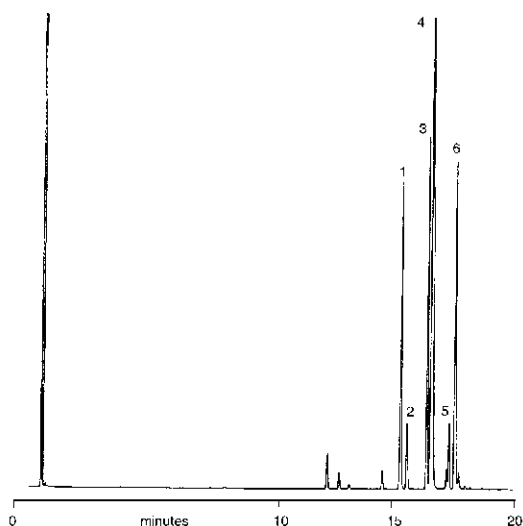

Components

1. (+) Neomenthol
2. (-) Neomenthol
3. (+) Menthol
4. (-) Menthol
5. (+) a-Terpineol
6. (-) a-Terpineol

Notes: Cydex - B column enables the separation of three different enantiomer pairs in Menthol Oil.

FLA 19 | Analysis of Eucalyptus Oil on SolGel-WAX™

Column Part No.:	054796	Constant Flow:	On
Phase:	SolGel-WAX™, 0.25 µm film	Average Linear Velocity:	35 cm/sec at 40 °C
Sample:	Neat	Injection Mode:	Split
Column:	30 m x 0.25 mm ID	Split Ratio:	100:1
Initial Temp.:	40 °C, 1 min.	Injection Volume:	0.2 µL
Rate 1:	8 °C/min to 220 °C,	Injection Temp.:	250 °C
Final Temp:	220 °C, 5 min.	Liner Type:	4 mm ID Single Taper Liner
Detector Type:	Mass Spectrometer	Liner Part Number:	092017
Carrier Gas:	He, 25.7 psi	Full Scan / SIM:	Full scan 45-450
Carrier Gas Flow:	1.8 mL/min.		

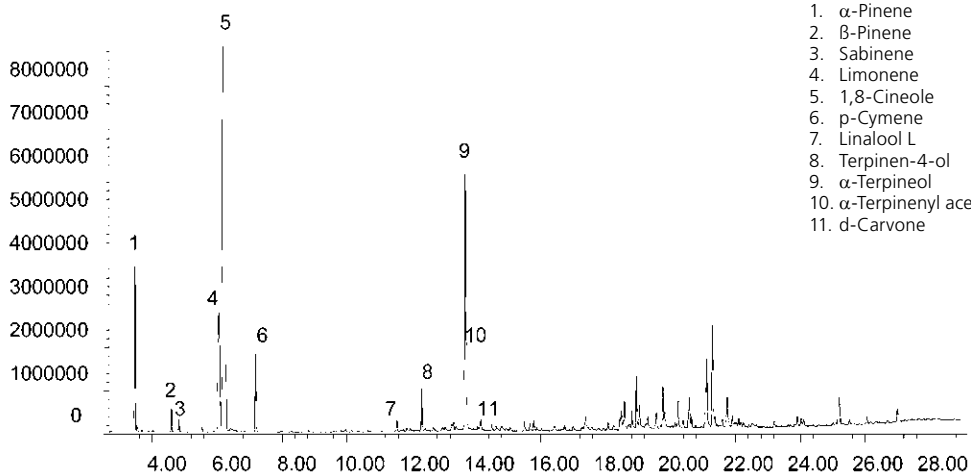

Components

1. α-Pinene
2. β-Pinene
3. Sabinene
4. Limonene
5. 1,8-Cineole
6. p-Cymene
7. Linalool L
8. Terpinen-4-ol
9. α-Terpineol
10. α-Terpinenyl acetate
11. d-Carvone





GC Columns and Applications

FOO 02 | Analysis of Food Additives Antimicrobials on BP5

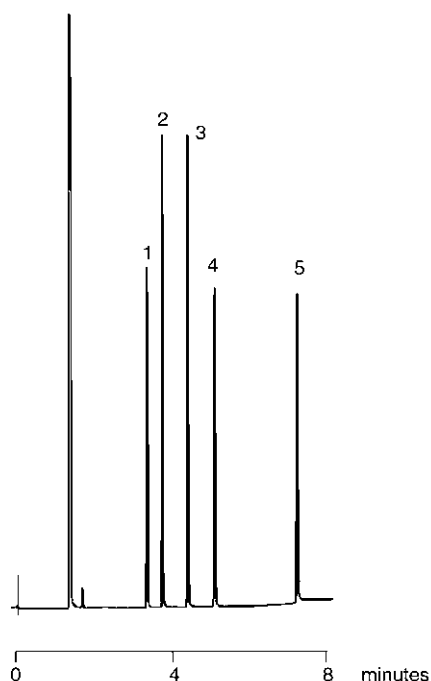

Column Part No.:	054186
Phase:	BP5, 0.5 µm film
Column:	25 m x 0.32 mm ID
Initial Temp:	160 °C, 0 min
Rate:	15 °C/min
Final Temp:	280 °C, 0 min
Detector:	FID
Sensitivity:	256 x 10 ⁻¹² AFS
Injection Mode:	Split

Components

1. Methyl Paraben
2. Ethyl Paraben
3. Propyl Paraben
4. Butyl Paraben
5. Heptyl Paraben

FOO 04 | Analysis Of 13 Sugar Component Alditol Acetate Mixture on BPX70

Column Part No.:	054622
Phase:	BPX70, 0.25 µm film
Column:	30 m x 0.25 mm I.D.
Initial Temp.:	190 °C, 1 min.
Program Rate:	3 °C/min.
Final Temp:	260 °C, 10min.
Carrier Gas:	He, 50 kPa
Detector:	MS (Electron Impact Ionisation, Ionisation Potential 70 eV) Scan 100 m/z to 350 m/z in 0.3 s.
Injection Mode:	Split 50:1

Components

1. Erythritol
2. 2-Deoxy-ribitol
3. Rhamnitol
4. Fucitol
5. Ribitol
6. Arabinitol
7. Xylitol
8. 2-Deoxy-glucitol
9. Allitol
10. Mannitol
11. Galacitol
12. Glucitol
13. Myo-inositol

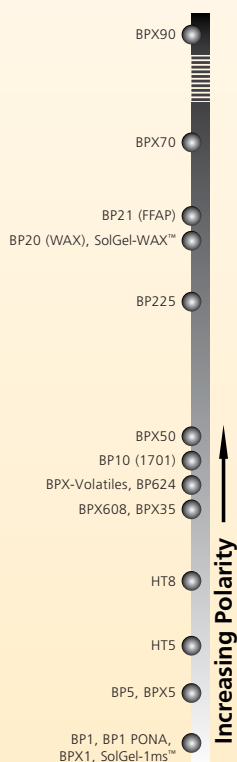
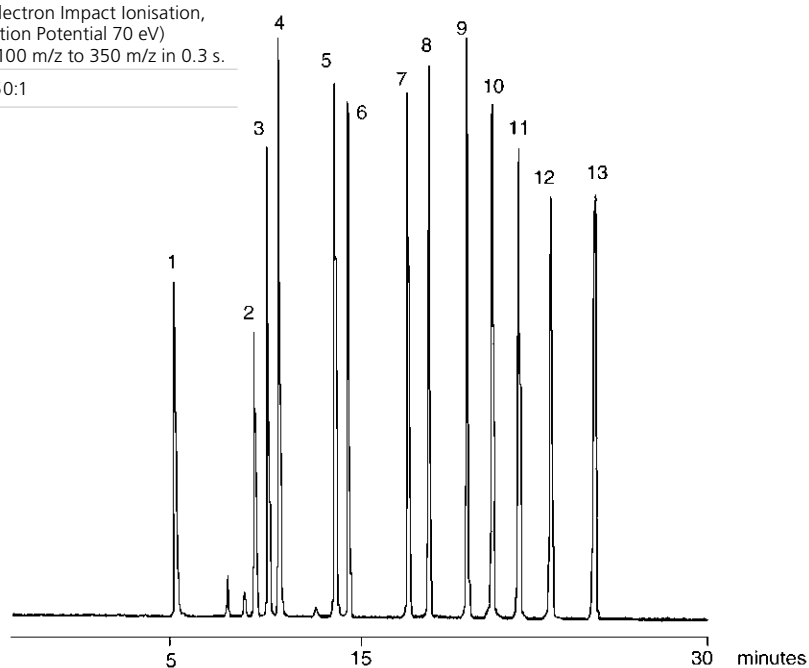

FOO 21 | Plant Sterols



GC Columns and Applications

Column Part No.:	054148
Phase:	BPX5, 1.0 µm
Column:	30 m x 0.53 mm ID
Initial Temp.:	320 °C
Detector:	FID, 360 °C
Injector Mode:	split 100:1
Carrier Gas:	He, 3 psi
Injection Volume:	1 µL

Components

- | | |
|-------------------|---------------------|
| 1. Coprosterol | 7. Campesterol |
| 2. Cholesterol | 8. Stigmasterol |
| 3. Cholestanol | 9. Unknown |
| 4. Desmosterol | 10. beta-Sitosterol |
| 5. Brassicasterol | 11. Lanosterol |
| 6. Ergosterol | |

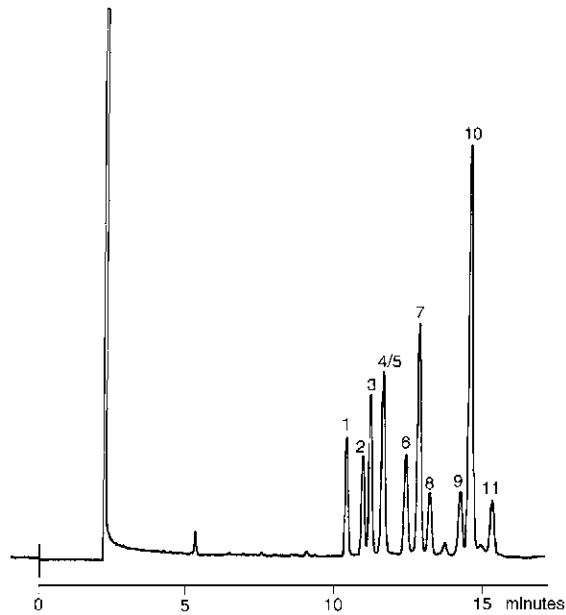

FOO 24 | Analysis of Wine on BP20

Column Part No.:	054442
Phase:	BP20, 1.0 µm
Column:	25 m x 0.32 mm ID
Initial Temp.:	40 °C, 2 min
Rate 1:	5 °C/min
Temp 2:	50 °C
Rate 2:	15 °C/min
Final Temp.:	190 °C
Carrier Gas:	H ₂ , 6 psi
Injection Mode:	2 µL

Components

- | | |
|------------------|--------------------|
| 1. Acetaldehyde | 6. Propanol |
| 2. Ethyl Acetate | 7. Isobutanol |
| 3. Methanol | 8. Isoamyl Alcohol |
| 4. Isopropanol | 9. Acetic Acid |
| 5. Ethanol | 10. Unknown |

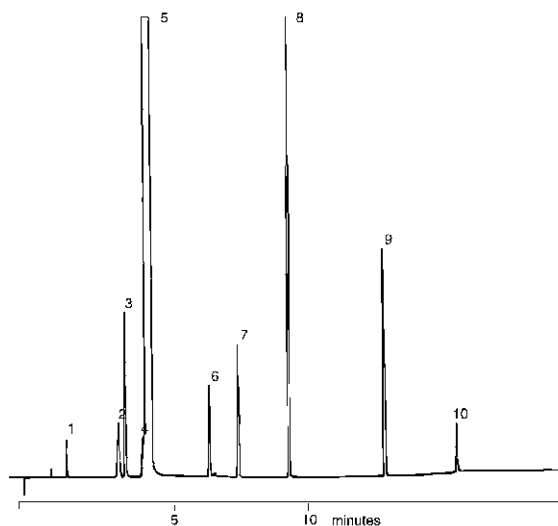



GC Columns and Applications

FLA 14 | Analysis of Lavender Oil on BPX5

Column Part No.:	054101
Phase:	BPX5, 0.2 5 µm film
Column:	30 m x 0.25 mm ID
Initial Temp.:	40 °C, 1 min
Rate 1:	5 °C/min to 260 °C
Final Temp.:	260 °C
Detector Type:	Mass Spectrometer
Carrier Gas:	He, 7.0 psi
Carrier Gas Flow:	1.0 mL/min
Constant Flow:	On

Average Linear Velocity:	36 cm/sec at 40 °C
Injection Mode:	Split
Split Ratio:	200:1
Purge on (Split)	
Vent Flow:	200 mL/min
Injection Volume:	0.2 µL
Injection Temp.:	250 °C
Liner Type:	4 mm ID Double Taper Liner
Liner Part Number:	092018

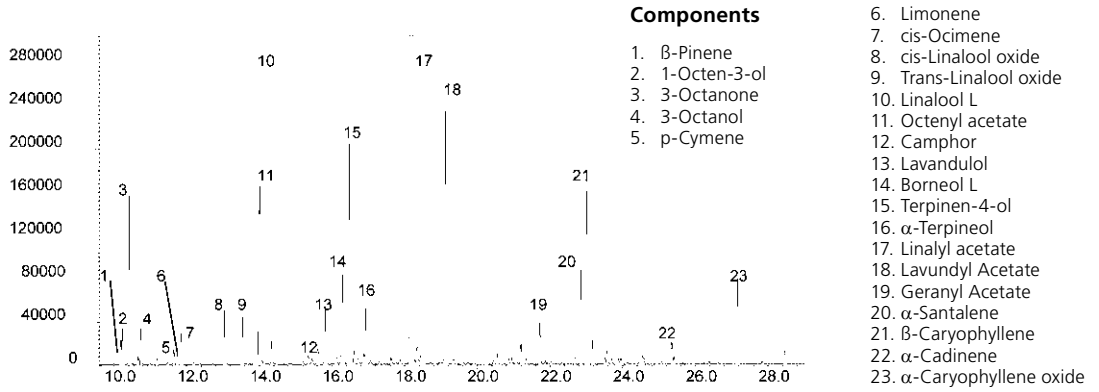

FLA 03 | Analysis of Orris Concentrate on BP20

Column Part No.:	054436
Column:	BP20, 0.5 µm
Phase:	25 m x 0.32 mm I.D.
Initial Temp.:	70 °C, 1 min
Rate:	10 °C/min
Final Temp.:	250 °C, 10 min
Carrier Gas:	Helium
Carrier Pressure:	10 psi
Injection Mode:	Split 50:1

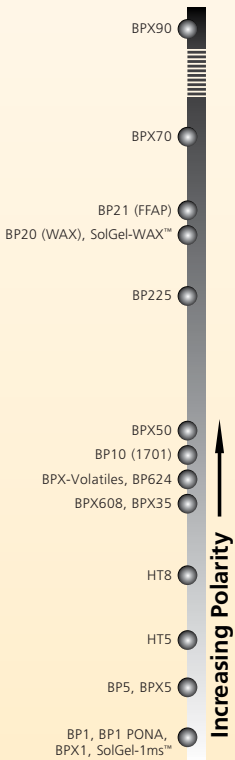
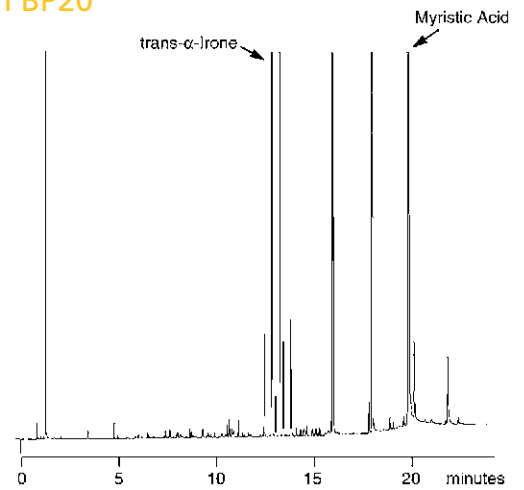

FLA 21 | Analysis of Spearmint Oil on SolGel-WAX™



GC Columns and Applications

Column Part No.:	054796	Constant Flow:	On
Phase:	SolGel-WAX™, 0.25 µm film	Average Linear Velocity:	35 cm/sec at 40 °C
Sample:	Neat	Injection Mode:	Split
Column:	30 m x 0.25 mm ID	Split Ratio:	100:1
Initial Temp.:	40 °C, 1 min.	Injection Volume:	0.2 µL
Rate 1:	8 °C/min to 220 °C	Injection Temp.:	250 °C
Final Temp:	220 °C, 5 min.	Liner Type:	4 mm ID Single Taper Liner
Detector Type:	Mass Spectrometer	Liner Part Number:	092017
Carrier Gas:	He, 25.7 psi	Full Scan / SIM:	Full scan 45-450
Carrier Gas Flow:	1.8 mL/min.		

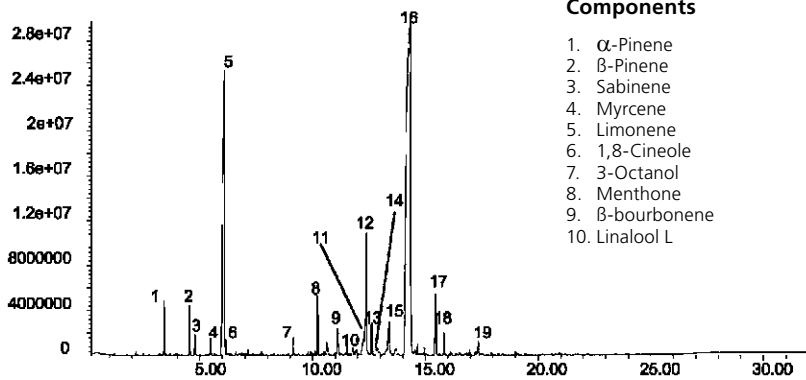

Components

- | | |
|------------------------|---------------------------------|
| 1. α -Pinene | 11. <i>trans</i> Caryophyllene |
| 2. β -Pinene | 12. <i>cis</i> dihydrocarvone |
| 3. Sabinene | 13. <i>trans</i> dihydrocarvone |
| 4. Myrcene | 14. Menthol |
| 5. Limonene | 15. Dihydrocarvyl acetate |
| 6. 1,8-Cineole | 16. L-Carvone |
| 7. 3-Octanol | 17. <i>trans</i> Carveol |
| 8. Menthone | 18. <i>cis</i> Carveol |
| 9. β -bourbonene | 19. Caryophyllene oxide |
| 10. Linalool L | |

FLA 18 | Analysis of Ylang Ylang Oil on SolGel-WAX™

Column Part No.:	054796	Constant Flow:	On
Phase:	SolGel-WAX™, 0.25 µm	Average Linear Velocity:	35 cm/sec at 40 °C
Sample:	Ylang Ylang oil neat.	Injection Mode:	Split
Column:	30 m x 0.25 mm ID	Split Ratio:	120:1
Initial Temp.:	40 °C, 2 min.	Injection Volume:	0.1 µL
Rate 1:	3 °C/min to 250 °C	Injection Temp.:	250 °C
Final Temp:	250 °C, 10 min.	Autosampler:	No
Detector Type:	Mass Spectrometer	Liner Type:	4 mm ID Double Taper Liner
Carrier Gas:	He, 25.7 psi	Liner Part Number:	092018
Carrier Gas Flow:	1.8 mL/min.	Full Scan / SIM:	Full scan 45-450

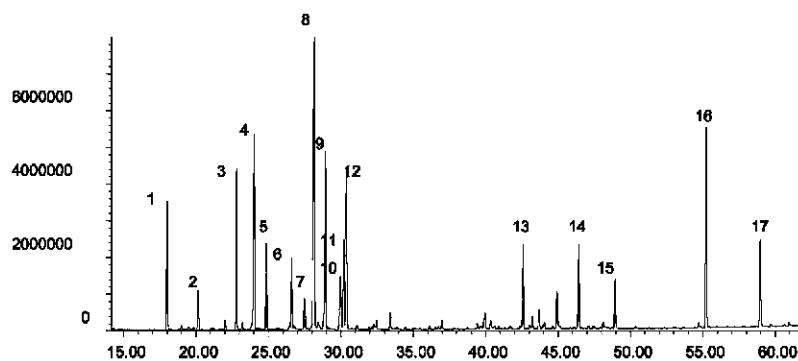

Components

1. p-Methyl anisole
2. α -Copaene
3. Linalool L
4. β -Caryophyllene
5. Methyl benzoate
6. α -Humulene
7. α -Amorphene
8. Germacrene
9. Benzyl acetate
10. δ -Cadinene
11. α -Farnesene
12. Geranyl acetate
13. *trans*-Cinamyl acetate
14. Farnesyl acetate
15. Farnesol
16. Benzyl benzoate
17. Benzyl salicylate





GC Columns and Applications

FLA 16 | Analysis of Pine Oil on BPX5

Column Part No.: 054101

Phase:	BPX5, 0.25 µm film
Column:	30 m x 0.25 mm ID
Initial Temp.:	40 °C, 1 min.
Rate 1:	5 °C/min to 260 °C
Final Temp:	260 °C
Detector Type:	Mass Spectrometer
Carrier Gas:	He, 7.0 psi
Carrier Gas Flow:	1.0 mL/min.
Constant Flow:	On

Average Linear Velocity:	36 cm/sec at 40 °C
Injection Mode:	Split
Split Ratio:	200:1
Purge on (Split)	
Vent Flow:	200 mL/min.
Injection Volume:	0.2 µL
Injection Temp.:	250 °C
Liner Type:	4 mm ID Double Taper Liner
Liner Part Number:	092018

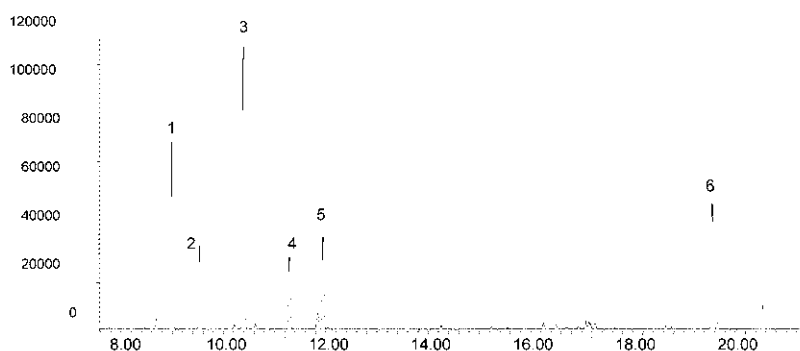
**Components**

1. α-Pinene
2. Camphene
3. β-Pinene
4. δ-3-Carene
5. Limonene
6. Endobornyl acetate

FLA 15 | Analysis of Tea Tree Oil on BPX5

Column Part No.: 054101

Phase:	BPX5, 0.25 µm film
Column:	30 m x 0.25 mm ID
Initial Temp.:	40 °C, 1 min.
Rate 1:	5 °C/min to 200 °C
Final Temp:	200 °C
Detector Type:	Mass Spectrometer
Carrier Gas:	He, 7.0 psi
Carrier Gas Flow:	1.0 mL/min.
Constant Flow:	On

Average Linear Velocity:	36 cm/sec at 40 °C
Injection Mode:	Split
Split Ratio:	200:1
Purge on (Split)	
Vent Flow:	200 mL/min.
Injection Volume:	0.2 µL
Injection Temp.:	250 °C
Liner Type:	4 mm ID Double Taper Liner
Liner Part Number:	092018

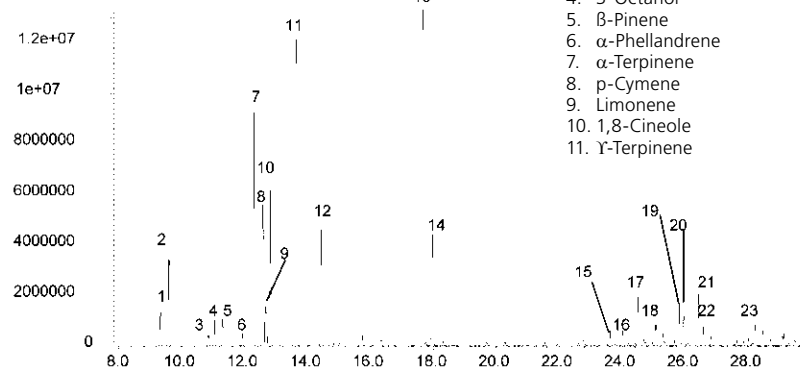
**Components**

1. Thujene
2. α-Pinene
3. Sabinene
4. 3-Octanol
5. β-Pinene
6. α-Phellandrene
7. α-Terpinene
8. p-Cymene
9. Limonene
10. 1,8-Cineole
11. γ-Terpinene
12. Terpinolene
13. Terpinen-4-ol
14. α-Terpineol
15. α-Gurjunene
16. (trans)-β-Caryophyllene
17. Aromadendrene
18. Alloaromadendrene
19. Ledene
20. Germacrene B
21. δ-Cadinene
22. 1s, cis-Calamenene
23. Globulol

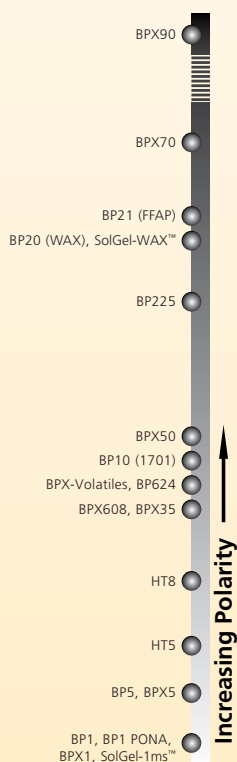

FLA 12 | Analysis of Nutmeg Oil on BPX5

Column Part No.:	054101	Constant Flow:	On
Phase:	BPX5, 0.25 µm film	Average Linear Velocity:	36 cm/sec at 40 °C
Column:	30 m x 0.25 mm ID	Injection Mode:	Split
Initial Temp.:	40 °C, 1 min.	Split Ratio:	200:1
Rate:	5 °C/min to 260 °C,	Purge on (Split) Vent Flow:	200 mL/min.
Final Temp:	260 °C	Injection Volume:	0.2 µL
Detector Type:	Mass Spectrometer	Injection Temp.:	250 °C
Carrier Gas:	He, 7.0 psi	Liner Type:	4 mm ID Double Taper Liner
Carrier Gas Flow:	1.0 mL/min.	Liner Part Number:	092018



GC Columns and Applications

Components

- | | |
|-------------------|----------------------------|
| 1. α-Thujene | 11. Limonene |
| 2. α-Pinene | 12. β-Phellandrene |
| 3. Camphene | 13. γ-Terpinene |
| 4. Sabinene | 14. trans-Sabinene hydrate |
| 5. β-Pinene | 15. α-Terpinolene |
| 6. Myrcene | 16. Terpinen-4-ol |
| 7. α-Phellandrene | 17. 1-α-Terpineol |
| 8. δ-3-Carene | 18. Safrole |
| 9. α-Terpinene | 19. α-Copaene |
| 10. p-Cymene | 20. Myristicin |
| | 21. Elemicin |

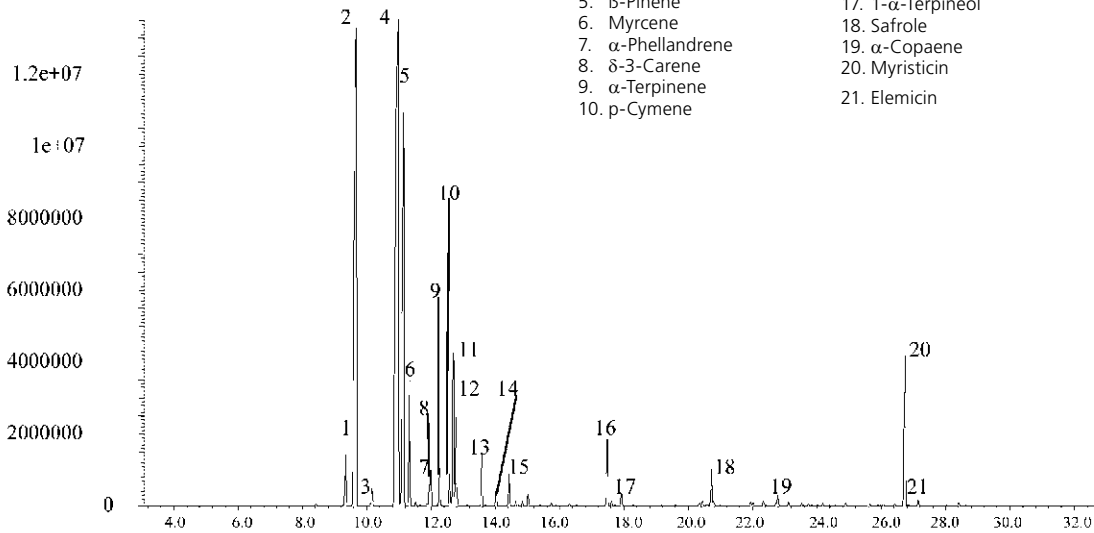



GC Columns and Applications

FLA 13 | Analysis of Rosemary Oil on BPX5

Column Part No.:	054101
Phase:	BPX5, 0.25 µm film
Column:	30 m x 0.25 mm ID
Initial Temp.:	40 °C, 1 min.
Rate 1:	5 °C/min to 260 °C,
Final Temp:	260 °C
Detector Type:	Mass Spectrometer
Carrier Gas:	He, 7.0 psi
Carrier Gas Flow:	1.0 mL/min.
Constant Flow:	On

Average Linear Velocity:	36 cm/sec at 40 °C
Injection Mode:	Split
Split Ratio:	200:1
Purge on (Split)	
Vent Flow:	200 mL/min.
Injection Volume:	0.2 µL
Injection Temp.:	250 °C
Liner Type:	4 mm ID Double Taper Liner
Liner Part Number:	092018

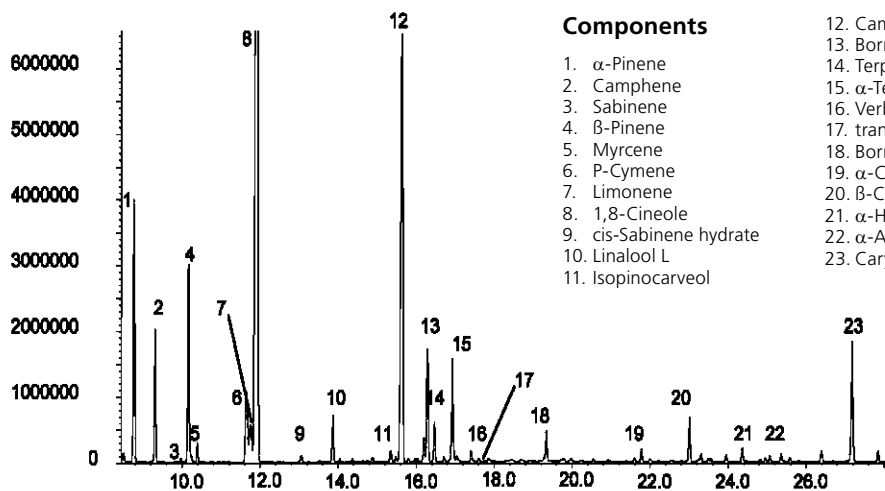

Components

- | | |
|-------------------------|-------------------------|
| 1. α-Pinene | 12. Camphor |
| 2. Camphene | 13. Borneol L |
| 3. Sabinene | 14. Terpinen-4-ol |
| 4. β-Pinene | 15. α-Terpineol |
| 5. Myrcene | 16. Verbenone |
| 6. P-Cymene | 17. trans-(+)-Carveol |
| 7. Limonene | 18. Bornyl acetate |
| 8. 1,8-Cineole | 19. α-Copaene |
| 9. cis-Sabinene hydrate | 20. β-Caryophyllene |
| 10. Linalool L | 21. α-Humulene |
| 11. Isopinocarveol | 22. α-Amorphene |
| | 23. Caryophyllene oxide |

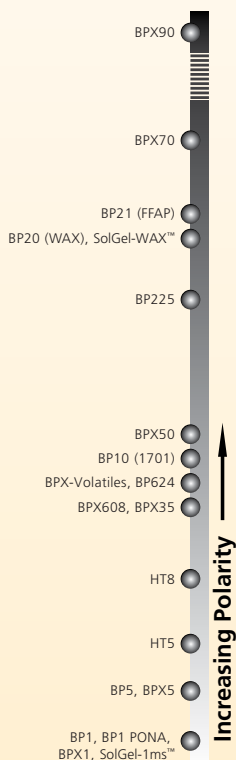

FLA 22 | Analysis of Tasmanian Lavender Oil on SolGel-WAX™

Column Part No.:	054796		
Phase:	SolGel-WAX™, 0.25 µm film	Constant Flow:	On
Sample:	Neat	Average Linear Velocity:	35 cm/sec at 40 °C
Column:	30 m x 0.25 mm ID	Injection Mode:	Split
Initial Temp.:	40 °C, 1 min.	Split Ratio:	100:1
Rate 1:	8 °C/min to 220 °C,	Injection Volume:	0.2 µL
Final Temp:	220 °C, 5 min.	Injection Temp.:	250 °C
Detector Type:	Mass Spectrometer	Liner Type:	4 mm ID Single Taper Liner
Carrier Gas:	He, 25.7 psi	Liner Part Number:	092017
Carrier Gas Flow:	1.8 mL/min.	Full Scan / SIM:	Full scan 45-450



GC Columns and Applications

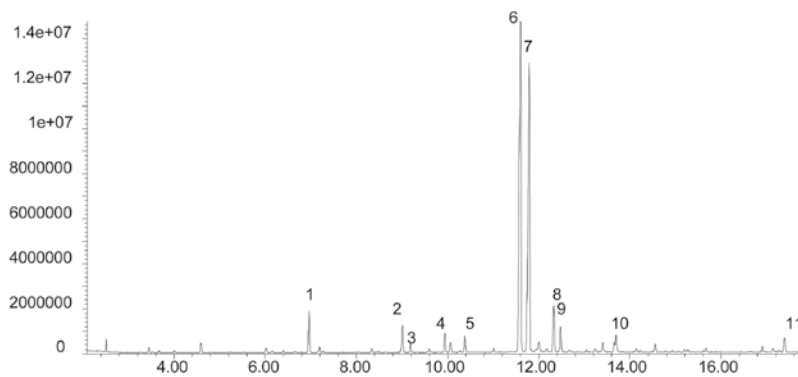

Components

1. 3-Octanone
2. Octenyl acetate
3. Octanol
4. Cis Linalool oxide
5. Trans Linalool Oxide
6. Linalool L
7. Linalyl acetate
8. Terpinen-4-ol
9. Lavandulyl acetate
10. Borneol L
11. Caryophyllene oxide





GC Columns and Applications

ENV 54 | Total Recoverable Petroleum Hydrocarbons (TRPH) Analysis on Standard and Fast BPX5

Column Part No.:	054101
Phase:	BPX5, 0.25 µm film
Column:	30 m x 0.25 mm ID
TRPH (C8-C40):	5 ng/ µL in dichloromethane
Initial Temp.:	40 °C , 2 min
Rate 1:	30 °C/min to 330 °C
Rate 2:	N/A
Final Temp.:	330 °C, 9 min
Detector Type:	FID, 350 °C
Carrier Gas:	He, 14.1 psi
Carrier Gas Flow :	1.29 mL/min
Constant Flow:	On
Average Linear Velocity:	40 cm/sec at 40 °C
Injection Mode:	Split, 120:1
Purge On Time:	N/A
Purge On (Split) Vent Flow:	160 mL/min
Injection Volume:	1 µL
Injection Temperature:	250 °C
Autosampler:	Yes
Liner Type :	4 mm ID FocusLiner™ with single taper
Liner Part Number:	092003

Column Part Number:	054099
Phase:	BPX5, 0.10 µm film
Column:	10 m x 0.10 mm ID
TRPH (C8-C40) Standard:	5 ng/ µL in dichloromethane
Initial Temp.:	40 °C , 1 min
Rate 1:	30 °C/min to 330 °C
Rate 2:	N/A
Final Temp.:	330 °C, 0 min
Detector Type:	FID, 350 °C
Carrier Gas:	He, 28 psi
Carrier Gas Flow :	0.52 mL/min
Constant Flow:	On
Average Linear Velocity:	55 cm/sec at 40 °C
Injection Mode:	Split, 120:1
Purge On Time:	N/A
Purge On (Split) Vent Flow:	62 mL/min
Injection Volume:	1 µL
Injection Temperature:	250 °C
Autosampler:	Yes
Liner Type :	2.3 mm ID FocusLiner™
Liner Part Number:	092005

NORMAL

Chromatogram showing separation of Total Recoverable Petroleum Hydrocarbons using a conventional 30 meter x 0.25 mm ID BPX5 column with a 0.25 micron film.

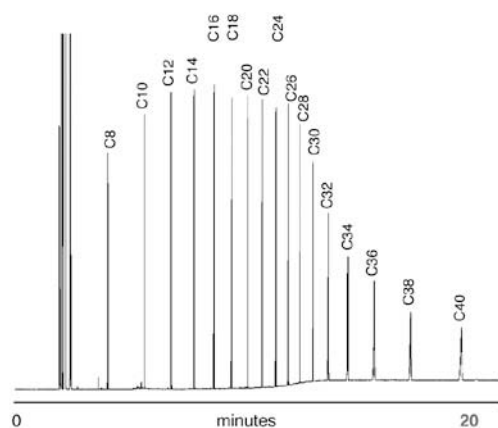

FAST

Chromatogram showing separation of Total Recoverable Petroleum Hydrocarbon using a FAST BPX5 column.

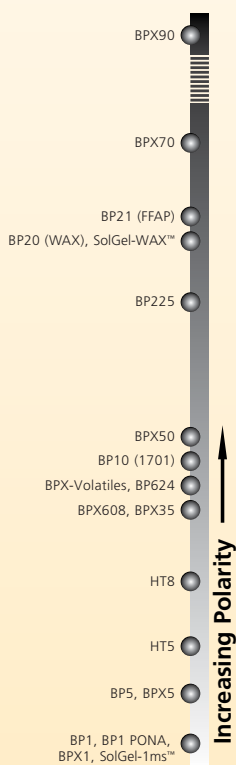
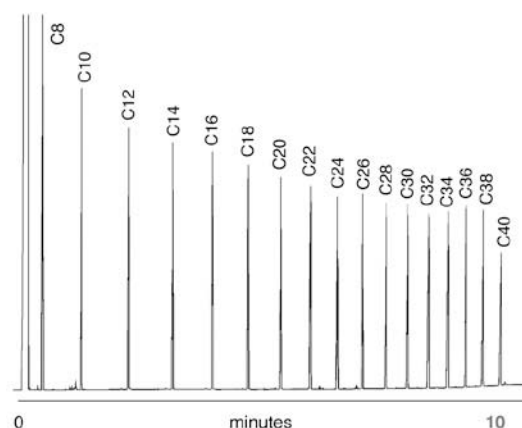

PET 01 | Analysis of Gasoline Range Hydrocarbons on BP1-PONA

Column Part No.:	054950	Temp. 3:	120 °C
Phase:	BP1 PONA	Rate 3:	10 °C/min
Column:	50 m x 0.15 mm ID	Final Temp.:	190 °C
Initial Temp.:	30 °C, 5 min hold	Detector:	FID
Rate 1:	2 °C/min	Sensitivity:	32 x 10-12 AFS
Temp. 2:	80 °C	Injection Mode:	Split
Rate 2:	50 °C/min	Carrier Gas:	H ₂ , 40 psi



GC Columns and Applications

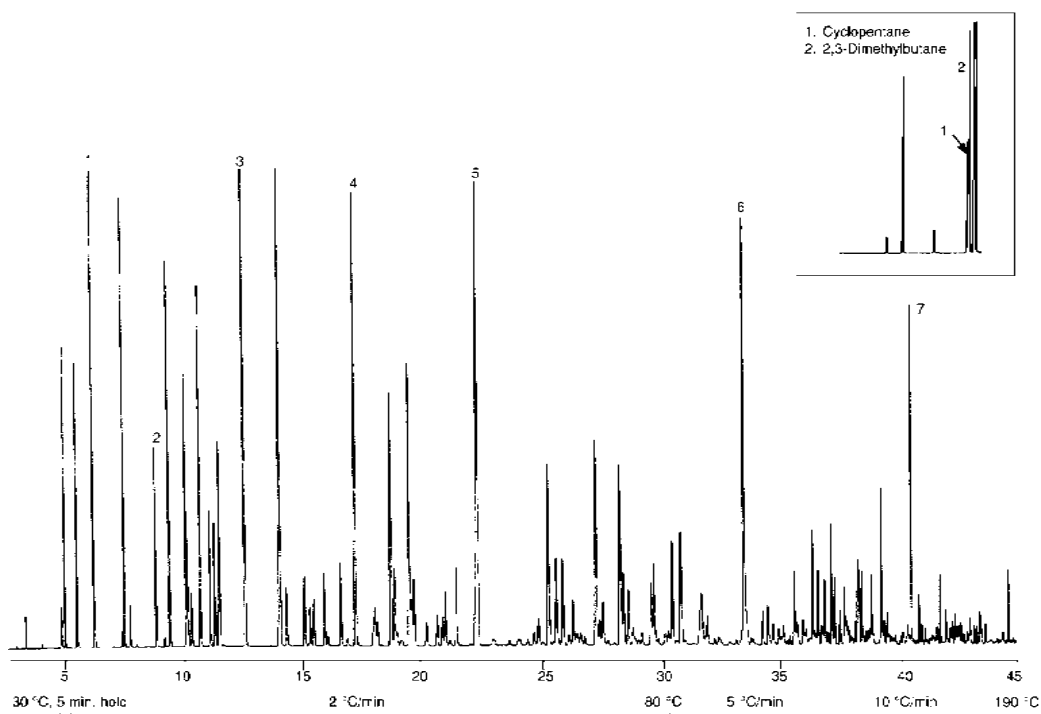

Components

TIME	COMPOUND
4.85	Cyclopentane
5.00	2,3-Dimethylbutane
5.25	2-Methylpentane
5.74	3-Methylpentane
6.45	n-Hexane
7.46	2,2-Dimethylpentane
7.60	Methylcyclopentane
7.91	2,4-Dimethylpentane
8.18	2,2,3-Trimethylbutane
8.99	Benzene
9.35	3,3-Dimethylpentane
9.55	Cyclohexane
10.23	2-Methylhexane
10.32	2,3-Dimethylpentane
10.47	1,1-Dimethylcyclohexane
10.83	3-Methylhexane
11.23	1-trans-3-Dimethylcyclopentane
11.43	1-cis-3-Dimethylcyclopentane
11.55	3-Ethylpentane
11.63	1-trans-2-Dimethylcyclopentane
11.78	2,2,4-Trimethylpentane
12.73	n-Heptane
14.23	Methylcyclohexane
14.53	2,2-Dimethylhexane
15.27	Ethylcyclopentane
15.49	2,5-Dimethylhexane
15.65	2,4-Dimethylhexane
16.09	1-trans-2-cis-4-Trimethylcyclopentane
16.24	2,3,4-Trimethylpentane
16.78	1-trans-2-cis-3-Trimethylcyclopentane
17.05	2,3,3-Trimethylpentane
17.39	Toluene
18.27	2,3-Dimethylhexane
18.43	2-Methyl-3-ethylpentane
18.84	2-Methylheptane
19.69	1-Methyl-2-ethylcyclopentane
18.98	4-Methylheptane
19.23	1-cis-2-cis-4-trans-Trimethylcyclopentane
19.50	3-Methylheptane
19.77	1-trans-4-Dimethylcyclohexane
20.73	1-Methyl-cis-2-ethylcyclopentane
20.86	1-Methyl-trans-3-ethylcyclopentane
21.08	1-Methyl-cis-3-ethylcyclohexane
21.27	1-Ethyl-1-methylcyclopentane
21.53	1-trans-2-Dimethylcyclohexane
22.43	n-Octane
23.05	iso-Propylcyclopentane
24.14	2.2.5-Trimethylhexane
24.19	2,2,4-Trimethylhexane
24.53	2,4,4-Trimethylhexane
24.79	2,3,5-Trimethylhexane
25.16	2,4-Dimethylheptane
25.41	n-Propylcyclopentane
25.73	1-cis-2-Dimethylcyclohexane
26.00	1,1,3-Trimethylcyclohexane
26.25	2,5-Dimethylheptane
26.44	3,3-Dimethylheptane
26.58	3,5-Dimethylheptane
26.77	4,4-Dimethylheptane
26.94	2,3,3-Trimethylhexane
27.43	Ethylbenzene
27.57	1-cis-3-cis-5-Trimethylpentane
27.69	1,1,4-Trimethylcyclohexane
27.88	2,3,4-Trimethylhexane
28.15	3,3,4-Trimethylhexane
28.42	m-Xylene
28.54	p-Xylene
28.74	2,3-Dimethylheptane
28.84	1-cis-2-trans-4-trans-Trimethylcyclohexane
28.95	1-cis-2-trans-4-cis-Trimethylcyclohexane
29.16	3,4-Dimethylheptane
29.31	3-Methylethylhexane
29.68	4-Methyloctane
29.81	2-Methyloctane
30.56	3-Methyloctane
30.93	o-Xylene
31.75	1-Methyl-2-propylcyclopentane and 1-Methyl-trans-4-ethylcyclohexane
31.98	1-Methyl-cis-4-ethylcyclohexane
32.46	3,3-Diethylpentane
32.89	2,2,6-Trimethylheptane
33.17	1,1,2-Trimethylcyclohexane
33.52	n-Nonane
34.26	iso-Propylbenzene
34.48	tert-Butylcyclopentane
34.68	tert-Butylbenzene
35.57	sec-Butylcyclopentane
36.33	3-Methylnonane
36.56	n-Propylbenzene
36.83	n-Propylcyclohexane
37.12	m-Ethyltoluene
37.24	p-Ethyltoluene
37.64	1,3,5-Trimethylbenzene
38.20	2-Methylnonane
38.36	o-Ethyltoluene
38.75	3,6-Dimethyloctane
38.75	1,2,4-Trimethylbenzene
40.32	n-Decane
40.63	1,2,3-Trimethylbenzene
41.57	4-Methyldecane
41.94	sec-Butylbenzene
42.45	n-Butylbenzene
44.54	n-Undecane





GC Columns and Applications

PET 11 | Analysis of Crude Oil and Wax Mixtures on HT5

Column Part No.:	054635	Final Temp.:	480 °C
Phase:	HT5, 0.1 µm	Carrier Gas:	H ₂ , 15 psi
Column:	12 m x 0.22 mm I.D. (Aluminum Clad)	Detector:	F.I.D.
Initial Temp.:	35 °C	Sensitivity:	32 x 10 ⁻¹² AFS
Program Rate:	10 °C/min.	Injection Mode:	Split

Notes: HT5 is the best column for the analysis of hydrocarbons C₁₀ - C₇₀.

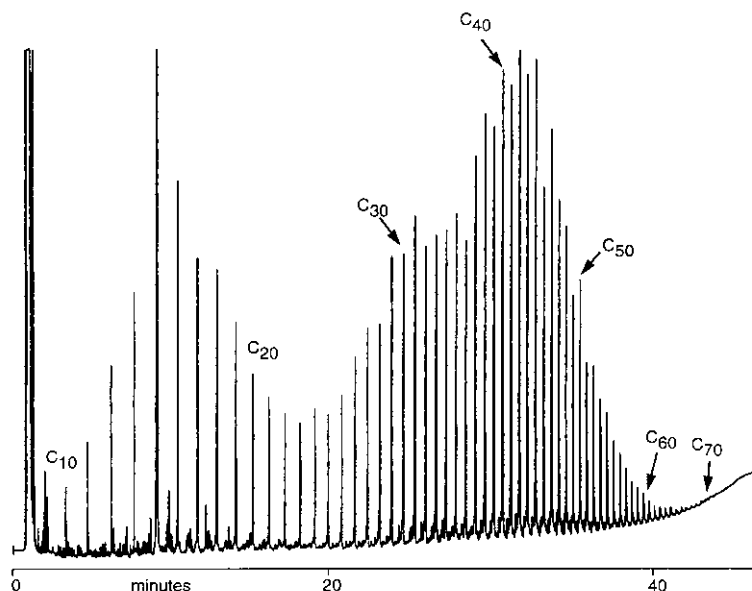

PET 26 | Standard for D2887 on BPX1

Column Part No.:	054802	Final Temp.:	350 °C, 10min
Phase:	BPX1, 2.65 µm film	Detector Temp.:	400 °C
Column:	10 m x 0.53 mm ID	Carrier Gas:	He, 20 mL/min
Initial Temp.:	40 °C	Instrument:	HP 6890
Rate:	15 °C/min		

Separation Systems Injector

Initial Temp.:	80 °C
Rate:	15 °C/min
Final Temp.:	350 °C, 10 min

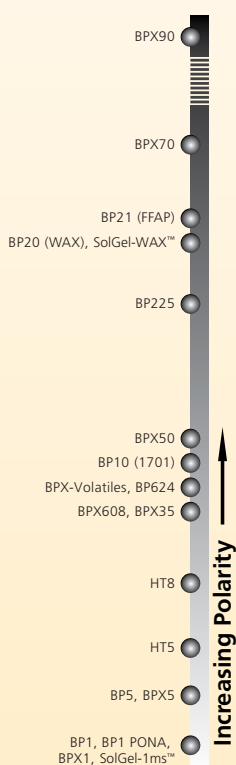
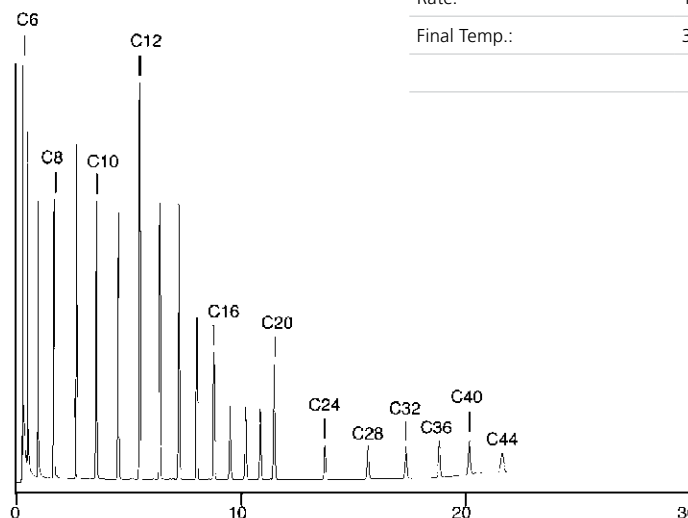

ENV 51 | Total Recoverable Petroleum Hydrocarbons (TRPH) C8-C40 on SolGel-1ms™

Column Part No.:	054795		
Phase:	SolGel-1, 0.25 µm film 30 m x 0.25 mm ID	Pressure:	16.6 psi
Sample Introduction:	Split / Splitless	Column Flow:	1.6 mL/min
Injector Temp.:	250 °C	Linear Velocity:	35 cm/sec at 40 °C
Injection Volume:	0.5 µL	Initial Temp:	40 °C
Autosampler Syringe:	5 µL Fixed Needle Part No. 001810	Initial Time:	2 min
Septa:	Auto-Sep T™ Part No. 041882	Rate 1:	30 °C/min
Injection Type:	Split	Final Temp.1:	310 °C
Purge On Time:	NA	Hold Time:	0 min
Purge On (Spilt) Vent:	100 mL/min	Rate 2:	10 °C/min
Split Ratio:	62.5 to 1	Final Temp. 2:	340 °C
Liner Type:	Double taper Part No. 092018	Hold Time:	0 min
Carrier Gas:	He	Run Time:	22.00 min
Constant Flow:	On	Detector Type:	FID at 340 °C



GC Columns and Applications

Sample Description: TRPH mix 500 mg/L, 4 ng per component on column.

Components

1. C8
2. C10
3. C12
4. C14
5. C16
6. C18
7. C20
8. C22
9. C24
10. C26
11. C28
12. C30
13. C32
14. C34
15. C36
16. C38
17. C40

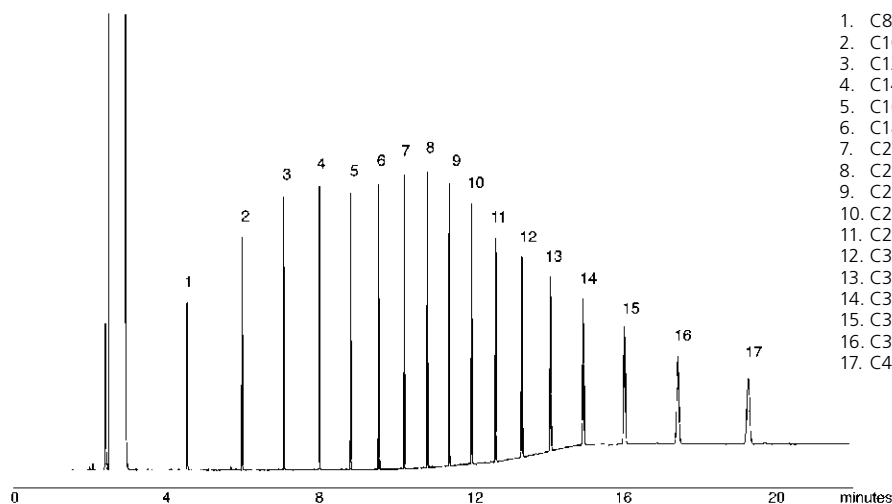

PET 27 | Analysis of Polywax 1000 on an Aluminum Clad HT5

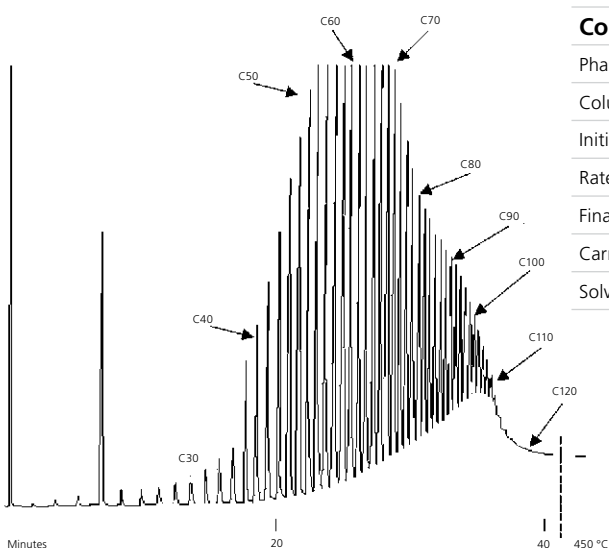

Column Part No.:	054673
Phase:	HT5, 0.075 µm film
Column:	5 m x 0.53 mm ID
Initial Temp.:	40 °C, 1 min
Rate:	10 °C/min
Final Temp.:	450 °C, 10 min
Carrier Gas:	He, 20 mL/min
Solvent:	CS ₂





GC Columns and Applications

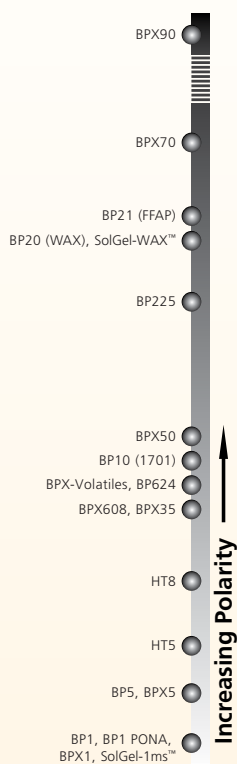

PET 22 | Unleaded Gasoline on BPX5

Column Part No.:	054101
Phase:	BPX5, 0.25 µm film
Column:	30 m x 0.25 mm ID
Sample Introduction:	Split / Splitless
Injector Temp.:	240 °C
Injection Volume:	0.1 µL
Autosampler Syringe:	0.5 µL Removable Needle Part No. 000410
Septa:	Auto-Sep T™ Part No. 041882
Injection Type:	Split
Purge On Time:	NA
Purge On (Split) Vent:	200 mL/min
Split Ratio:	149 to 1
Liner Type:	FocusLiner™ single taper Part No. 092003
Carrier Gas:	He

Constant Flow:	On
Pressure:	13.6 psi
Column Flow:	1.34 mL/min
Linear Velocity:	30 cm/sec at 25 °C
Initial Temp.:	25 °C
Initial Time:	1 min
Rate 1:	30 °C/min
Final Temp. 1:	240 °C
Hold Time:	1 min
Run Time:	9.17 min
Final Temp. 2:	340 °C
Hold Time:	0 min
Run Time:	22.00 min
Detector Type:	FID at 280 °C

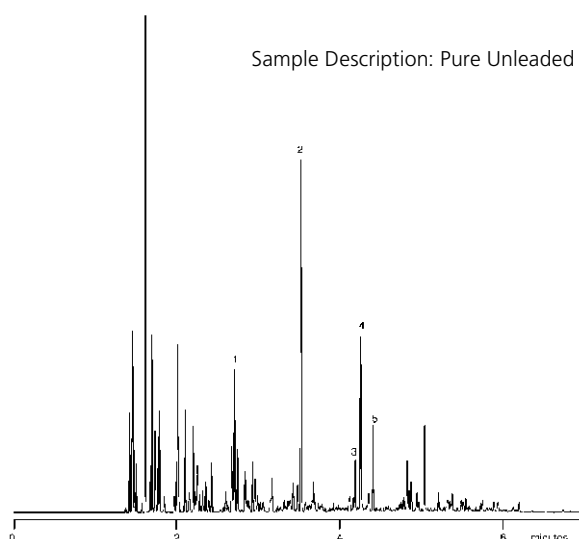

Components

1. Benzene
2. Toluene
3. Ethylbenzene
4. m, p - Xylene
5. o - Xylene

PET 18 | Analysis of Polywax 655 on Megabore BPX1

Column Part No.:	054800
Phase:	BPX1, 0.1 µm
Column:	5 m x 0.53 mm ID
Initial Temp:	40 °C
Rate:	15 °C

Final Temp:	420 °C, 5 min
Detector Temp:	440 °C
Carrier:	He, 10 mL/min
Instrument:	HP 6890
Solvent:	CS ₂

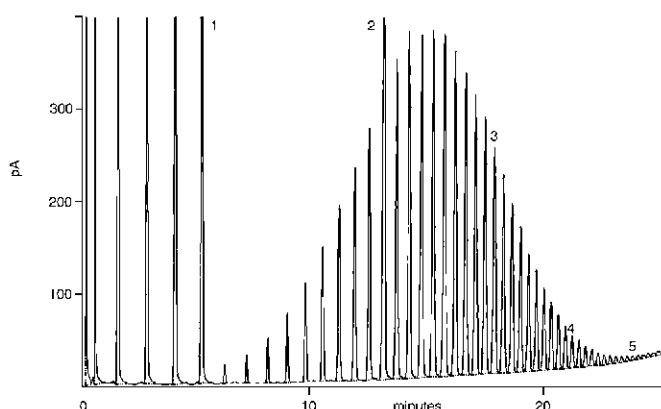

PET 06 | Analysis of Polywax 655 and Refinery Lubrication Oil on HT5

Column Part No.:	054661
Phase:	HT5, 0.1 µm
Column:	6 m x 0.53 mm ID
Initial Temp.:	50 °C
Rate:	10 °C/min
Final Temp.:	480 °C, 15 min

Detector:	FID
Sensitivity:	40 x 10 ⁻¹² AFS
Injection Mode:	On-Column
Carrier Gas:	Hydrogen, 20 ml/min
Solvent:	CS ₂



GC Columns and Applications

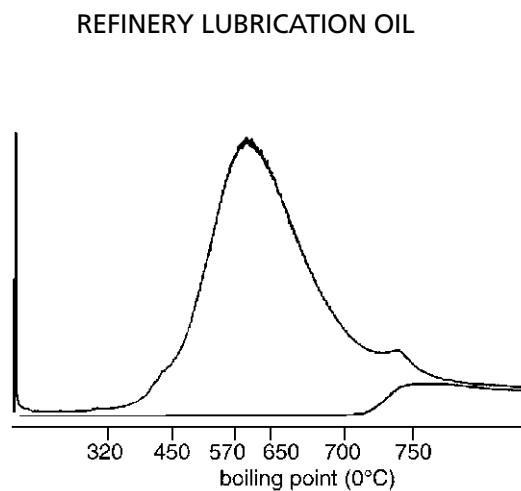
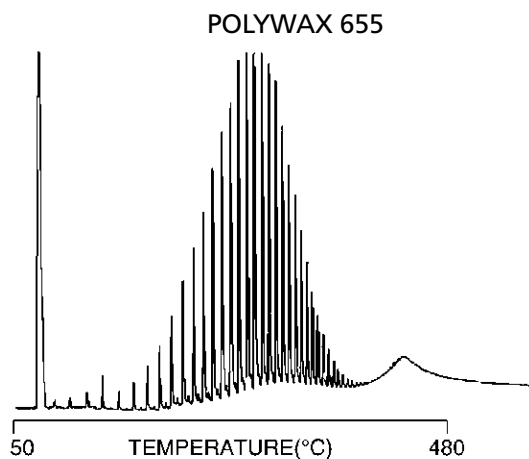

ENV 54 | BPX1 A New Era in Simulated Distillation Technology (SimD)

Column Part No:	054800
Phase:	BPX1, 0.1 µm
Column:	5 m x 0.53 mm ID
Initial Temp.:	40 °C
Rate:	15 °C
Final Temp.:	420 °C, 5 min.

Detector Temp:	440 °C
Carrier Gas:	Helium, 10 mL/min
Instrument:	HP6890
Initial Temp.:	40 °C
Rate:	15 °C
Final Temp.:	420 °C, 5 min.

Data supplied by Dr. J. Lubkowitz and the staff at Separation Systems Inc.

Figure. 1. Standard mix for HTSD using BPX1-SimD

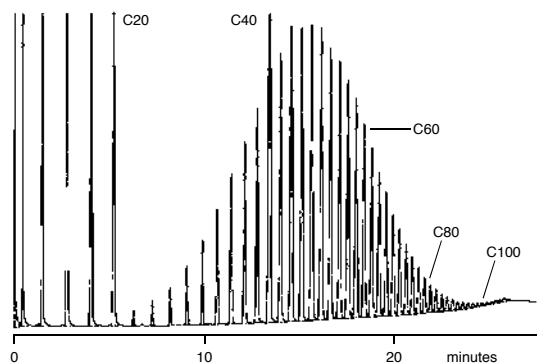
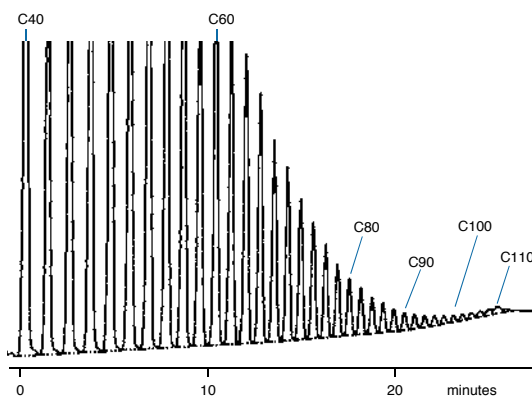
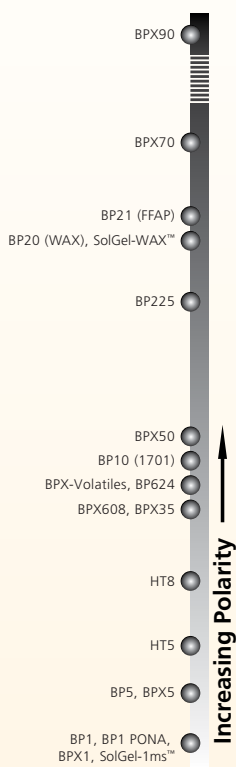

Figure. 2. Enlarged section of Figure 1.





GC Columns and Applications



ALC 02 | Analysis of 18 Alcohols on BP20

Column Part No.:	054427		
Phase:	BP20, 0.25 µm film	Final Temp:	80 °C, 0 min
Column:	30 m x 0.25 mm ID	Detector:	FID
Initial Temp:	45 °C, 2 min	Sensitivity:	128 x 10 ⁻¹² AFS
Rate:	3 °C/min	Injection Mode:	Split

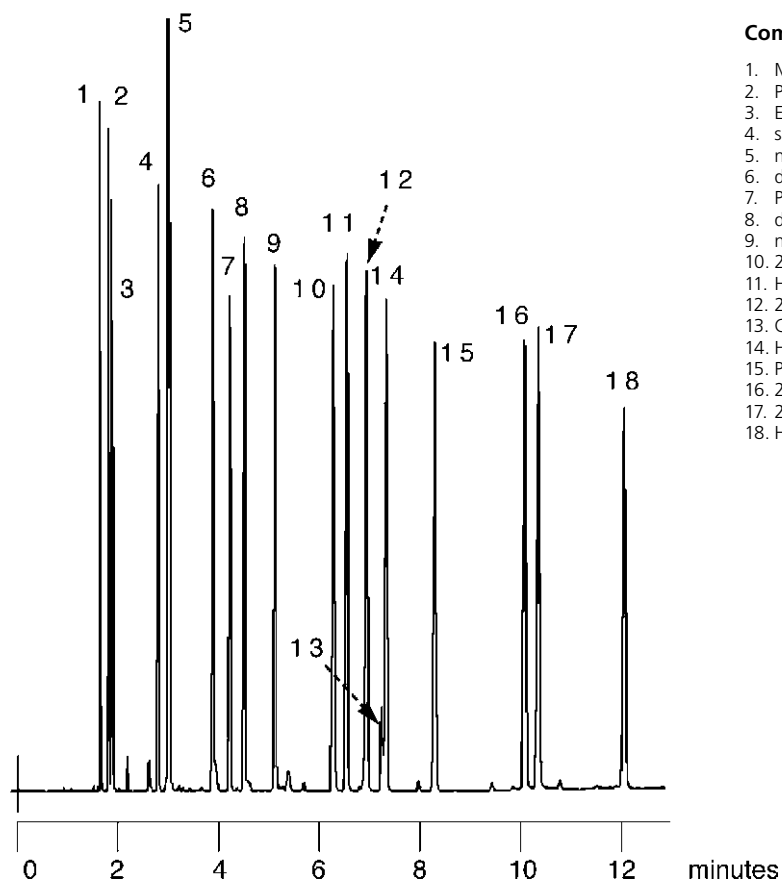

Components

1. Methanol
2. Propan-2-ol
3. Ethanol
4. sec-Butan-1-ol
5. n-Propanol + 2-Methyl-3-Buten-2-ol
6. d,l-3-Methyl-2-Butan-1-ol
7. Pentan-3-ol
8. d,l-2-Pentan-1-ol
9. n-Butanol
10. 2,4-Dimethyl, Pentan-3-ol
11. Hexan-3-ol
12. 2-Methyl Prop-2-en-1-ol
13. Crotyl Alcohol (2-Buten-1-ol)
14. Hexan-2-ol
15. Pentan-1-ol
16. 2-Methyl Pentan-1-ol
17. 2-Ethyl Butan-1-ol
18. Hexan-1-ol

ACI 03 | Analysis of 11 Organic Acids on BP20

Column Part No.:	054427		
Phase:	BP20, 0.25 µm film	Detector:	FID
Column:	30 m x 0.25 mm ID	Sensitivity:	32 x 10 ⁻¹² AFS
Initial Temp:	Isothermal at 155 °C	Injection Mode:	Split

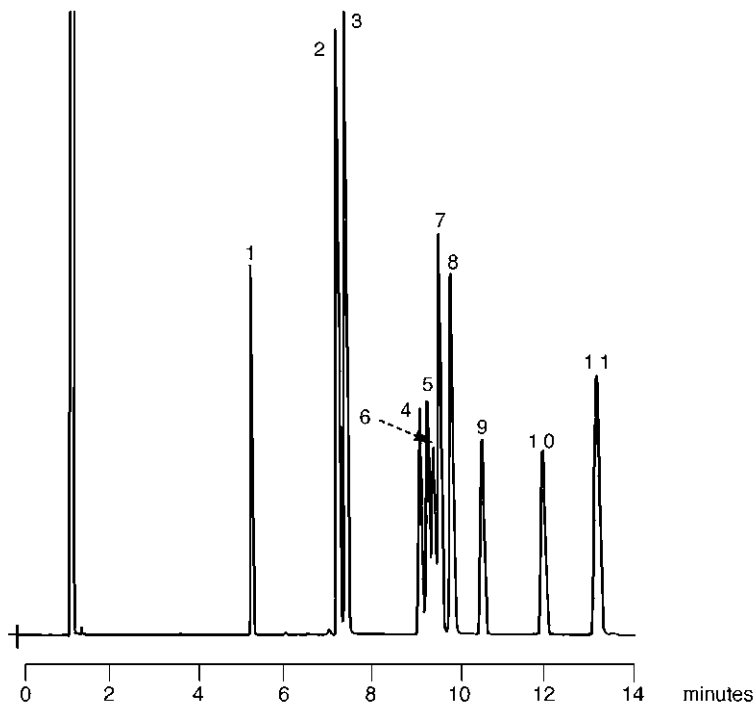

Components

1. 2,6-Xylenol
2. o-Cresol
3. Phenol
4. o-Ethylphenol
5. 2,5-Xylenol
6. p-Cresol
7. 2,4-Xylenol
8. m-Cresol
9. 2-iso Propylphenol
10. 2,3-Xylenol
11. 3,5-Xylenol + p-Ethylphenol

Notes: BP20 column completely resolves the three cresol isomers.

ACI 02 | Analysis of Organic Acids in Water on BP21

Column Part No.:	054477		
Phase:	BP21, 0.5 µm film	Final Temp:	180 °C, 5 min
Column:	30 m x 0.53 mm ID	Detector:	FID
Initial Temp:	85 °C, 0 min	Sensitivity :	64 x 10 ⁻¹² AFS
Rate:	6 °C/min	Injection Mode:	On-Column

Notes: On-column injection and the addition of a 0.03 M Oxalic acid (2%) to the injection solution increases the acidity of the column to allow lactic acid to be detected.

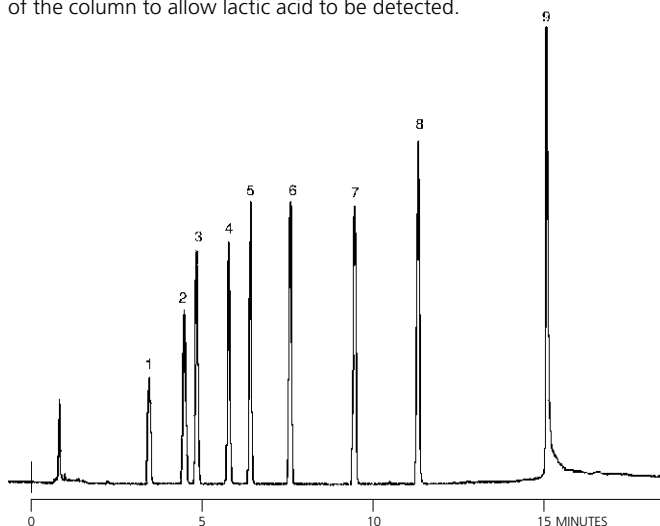

Components

1. Acetic Acid
2. Propanoic Acid
3. iso-Butyric Acid
4. n-Butyric Acid
5. iso-Valeric Acid
6. n-Valeric Acid
7. n-Caproic Acid
8. n-Heptanoic Acid
9. Lactic Acid



GC Columns and Applications



GC Columns and Applications

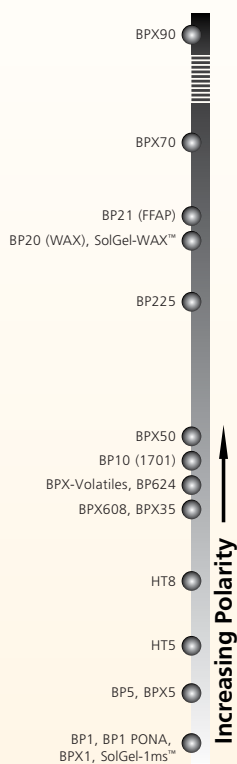

AMI 06 | Analysis of Aromatic Amines from Diazo Dyes on BPX35

Column Part No.: 054701

Phase:	BPX35 0.25 µm film
Azo Dyes standard:	10 ppm solution in DCM
Column:	30 m x 0.25 mm ID
Initial Temp:	50 °C, 2 min
Rate 1:	15 °C to 240 °C
Rate 2:	10 °C to 280 °C
Final Temp:	280 °C, 25 min
Detector Type:	MS D
Carrier Gas:	He, 7.1 psi
Carrier Gas Flow:	1.0 mL/min

Constant Flow:	On
Average Linear Velocity:	36 cm/sec at 50 °C
Injection Mode:	Splitless
Purge on Time:	1.0 min
Purge on (Split)	
Vent Flow:	60 mL/min
Injection Volume:	1 µL
Injection Temp:	250 °C
Liner Type:	4 mm ID Double Taper Liner
Liner Part No.:	092018

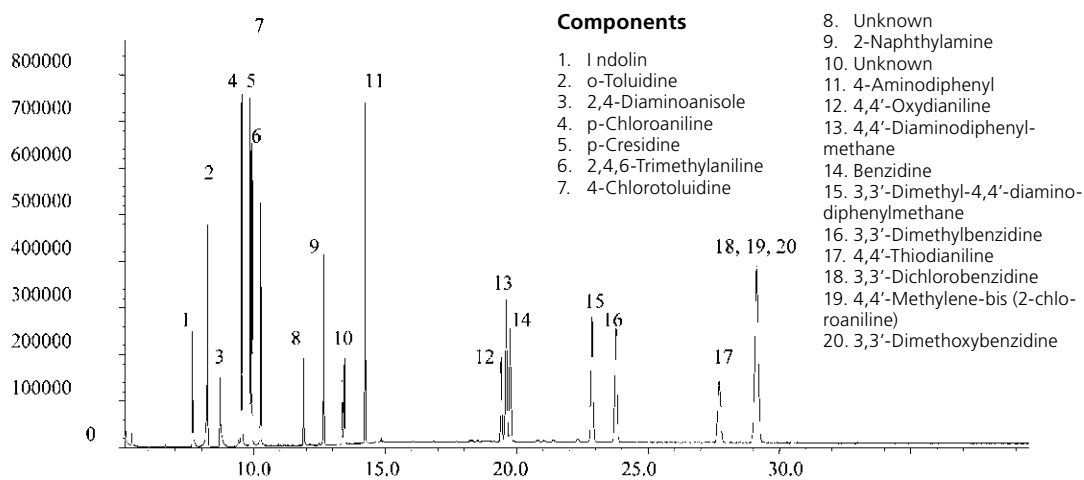

AMI 03 | Analysis of Aromatic Amines on BP5

Column Part No.: 054197

Phase:	BP5, 1.0 µm film
Column:	12 m x 0.53 mm ID
Initial Temp:	60 °C, 0 min
Rate:	10 °C/min

Final Temp:	190 °C, 0 min
Detector:	FID
Sensitivity :	128 x 10-12 AFS
Injection Mode:	Split

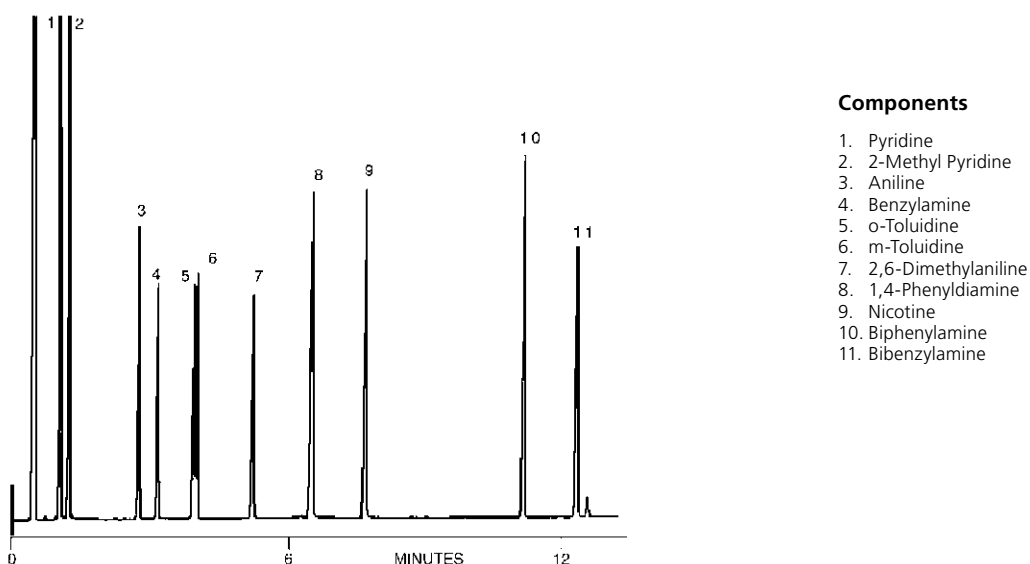

AMI 04 | Analysis of Amines on BP1

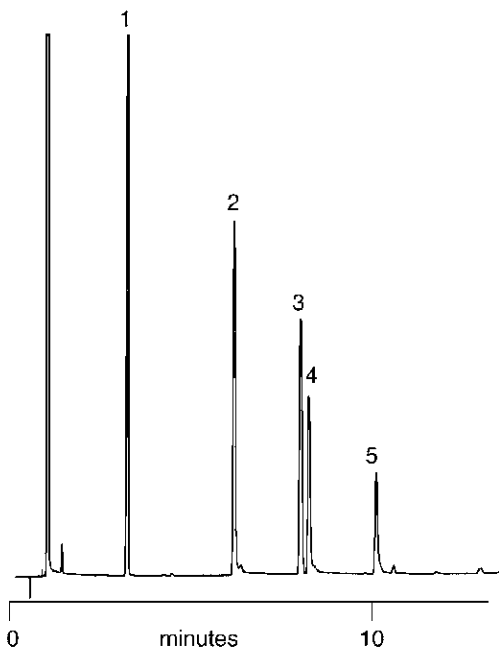

Column Part No.:	054097
Phase:	BP1, 3.0 µm film
Column:	12 m x 0.53 mm ID
Initial Temp.:	70 °C
Rate:	10 °C/min
Final Temp.:	250 °C
Carrier Gas:	Nitrogen
Injection Volume:	0.1 µL

Components

1. Aniline
2. Decylamine
3. Dicyclohexylamine
4. Dodecylamine
5. Tetradecylamine



GC Columns and Applications

SOL 25 | Analysis of 22 Ketones on BPX35

Column Part No.:	054701	Constant Flow:	On
Phase:	BPX35, 0.25 µm film	Average Linear Velocity:	35 cm/sec at 40 °C
Sample:	300 ppm in dichloromethane	Injection Mode:	Split
Column:	30 m x 0.25 mm ID	Split Ratio:	80:1
Initial Temp.:	40 °C, 5 min.	Injection Volume:	0.5 µL
Rate:	10 °C/min to 170 °C	Injection Temp.:	250 °C
Final Temp.:	170 °C, 5 min.	Liner Type:	4 mm ID Single Taper Liner
Detector Type:	Mass Spectrometer	Liner Part Number:	092017
Carrier Gas:	He, 25.6 psi	Full Scan / SIM:	Full scan 45-450
Carrier Gas Flow:	1.6 mL/min.		

Components

- | | | |
|-------------------------|-------------------------|-------------------|
| 1. Acetone | 7. 3-Methyl-2-pentanone | 15. 3-Heptanone |
| 2. 2-Butanone | 8. 3-Hexanone | 16. 2-Heptanone |
| 3. 3-Methyl-2-butanone | 9. 2-Hexanone | 17. Cyclohexanone |
| 4. 2-Pentanone | 10. Mesityl oxide | 18. 2-Octanone |
| 5. 3-Pentanone | 11. 2-Methyl-3-hexanone | 19. 2-Nonanone |
| 6. 4-Methyl-2-pentanone | 12. Cyclopentanone | 20. 2-Decanone |
| | 13. 4-Methyl-2-hexanone | 21. 2-Undecanone |
| | 14. 5-Methyl-2-hexanone | 22. 2-Dodecanone |

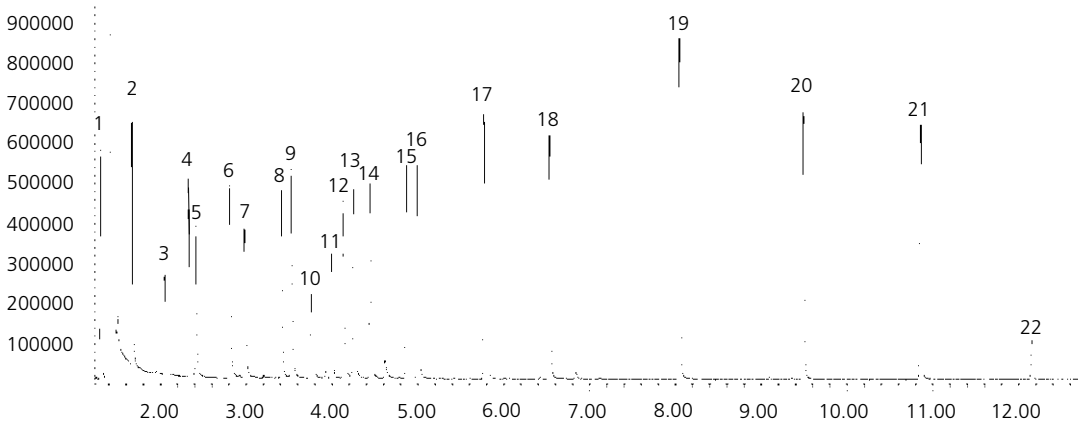



GC Columns and Applications

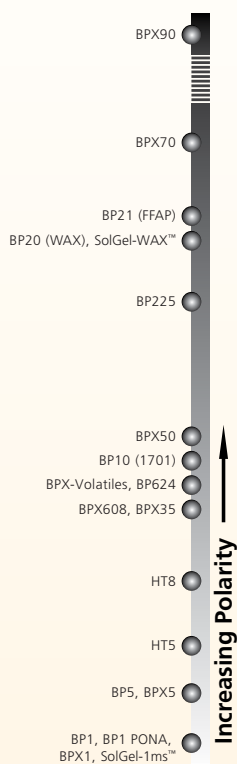

SOL 33 | Analysis of Ketones on Thick Film BPX5

Column Part No.:	054123	Carrier Gas:	He, 27.6 psi
Phase:	BPX5, 1.0 µm film	Carrier Gas Flow:	1.9 mL/min.
Sample:	300 ppm in dichloromethane	Constant Flow:	On
Column:	60 m x 0.25 mm ID	Average Linear Velocity:	35 cm/sec at 40 °C
Initial Temp.:	40 °C, 5 min.	Injection Mode:	Split
Rate 1: 1	0 °C/min to 80 °C	Split Ratio:	100:1
Rate 2:	30 °C/min to 260 °C	Injection Volume:	0.4 µL
Final Temp:	260 °C, 4 min.	Injection Tem.:	250 °C
Detector Type:	FID	Liner Type:	4 mm ID Single Taper Liner
Detector Temp.:	360 °C	Liner Part Number:	092017

Components

- | | | |
|-------------------------|-------------------------|-------------------|
| 1. Ethanol | 8. 3-Methyl-2-pentanone | 17. 2-Heptanone |
| 2. Acetone | 9. 3-Hexanone | 18. Cyclohexanone |
| 3. 2-Butanone | 10. 2-Hexanone | 19. 2-Octanone |
| 4. 3-Methyl-2-butanone | 11. Mesityl oxide | 20. 2-Nonanone |
| 5. 2-Pentanone | 12. Cyclopentanone | 21. 2-Decanone |
| 6. 3-pentanone | 13. 2-Methyl-3-hexanone | 22. 2-Undecanone |
| 7. 4-Methyl-2-pentanone | 14. 4-Methyl-2-hexanone | 23. 2-Dodecanone |
| | 15. 5-Methyl-2-hexanone | |
| | 16. 3-Heptanone | |

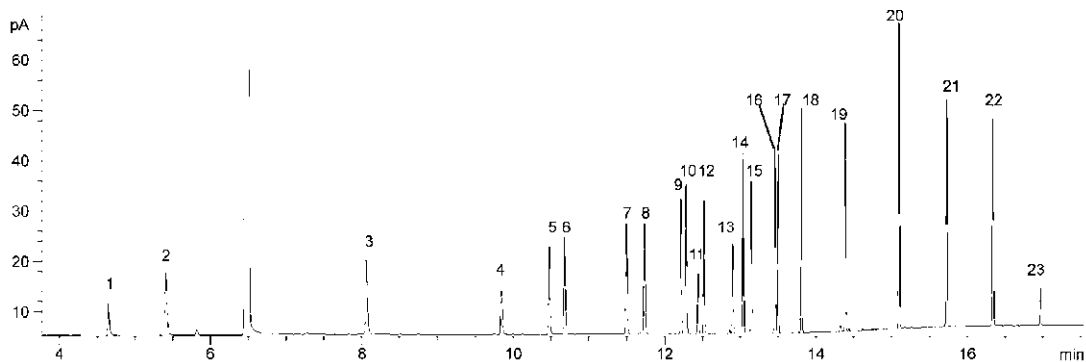

ALC 09 | Analysis of Phenols Mixture on BPX35



GC Columns and Applications

Column Part No:	054701		
Phase:	BPX35, 0.25 µm film	Constant Flow:	On
Sample:	200 ppm in methanol	Average Linear Velocity:	35 cm/sec at 80 °C
Column:	30 m x 0.25 mm ID	Injection Mode:	Split
Initial Temp:	80 °C, 1 min	Split Ratio:	100:1
Rate 1:	10 °C/min to 300 °C	Injection Volume:	1 µL
Final Temp:	300 °C, 5 min	Injection Temperature:	250 °C
Detector Type:	Mass Spectrometer	Liner Type:	4 mm ID Single Taper Liner
Carrier Gas:	He, 29.2 psi	Liner Part No.:	092017
Carrier Gas Flow:	1.7 mL/min.	Full Scan / SIM:	Full scan 45-450

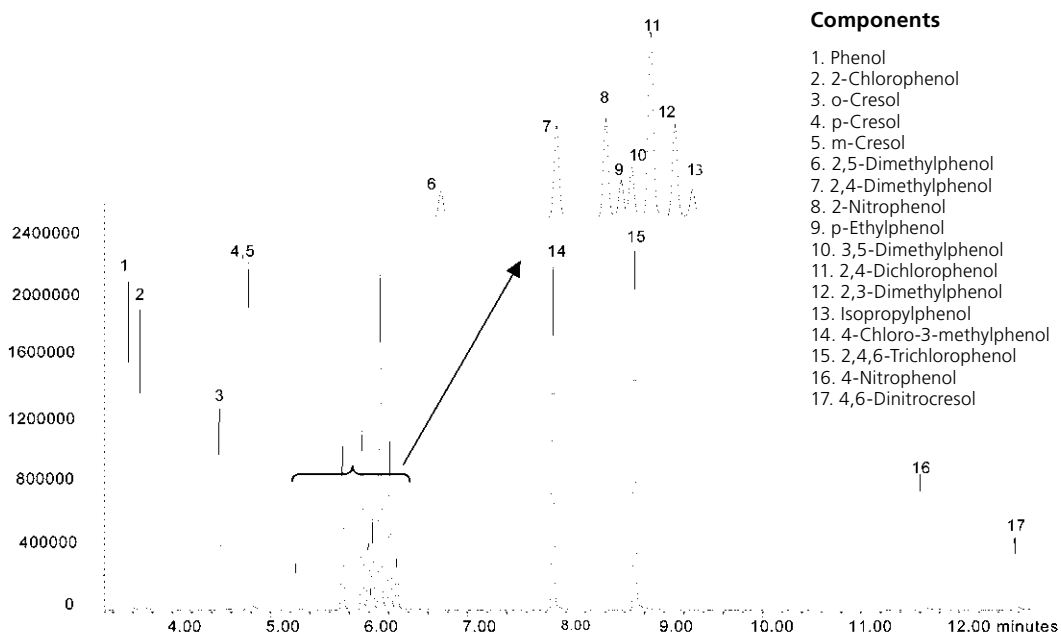



GC Columns and Applications

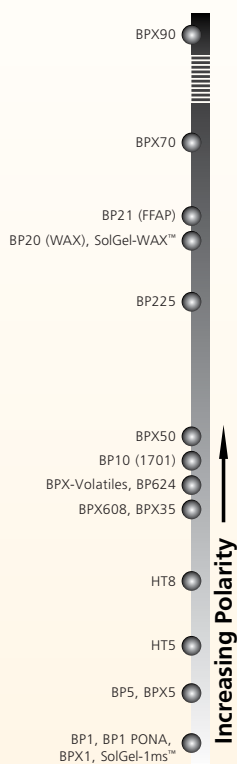

POL 06 | Analysis of Various Monomers on SolGel-WAX™

Column Part No.:	054796
Phase:	SolGel-WAX, 0.25 µm film
Sample:	250 ppm in Hexane
Column:	30 m x 0.25 mm ID
Initial Temp:	40 °C, 1 min.
Rate 1:	10 °C/min to 250 °C
Final Temp:	250 °C,
Detector Type:	FID
Detector Temp.:	320 °C
Carrier Gas:	He, 16.6 psi

Carrier Gas Flow:	1.6 mL/min.
Constant Flow:	On
Average Linear Velocity:	35 cm/sec at 40 °C
Injection Mode:	Split
Split Ratio:	80:1
Injection Volume:	1 µL
Injection Temperature:	250 °C
Autosampler:	No
Liner Type:	4 mm ID Single Taper Liner
Liner Part Number:	092017

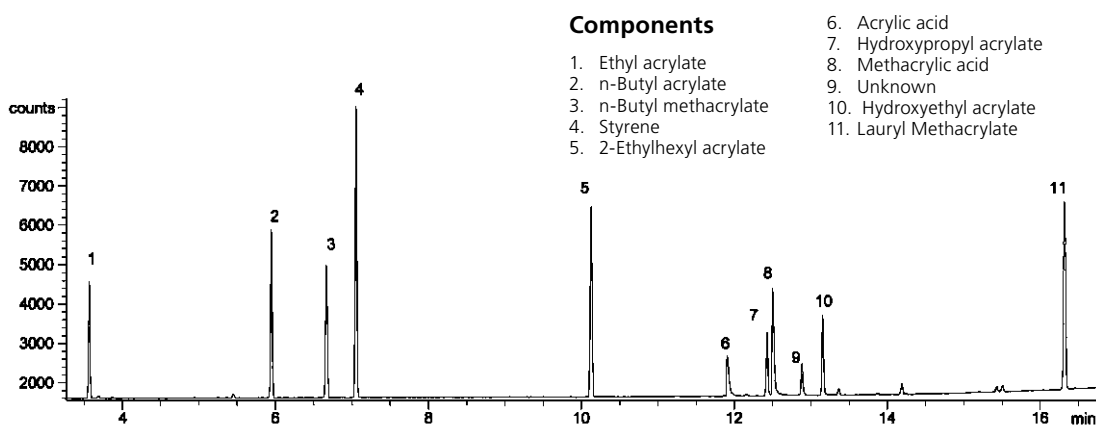

POL 01 | Analysis of Unreacted Monomers in Latex on BP20

Column Part No.:	054488
Phase:	BP20, 1.0 µm
Column:	25 m x 0.53 mm ID
Initial Temp.:	40 °C, 2 min
Rate:	10 °C/min

Final Temp.:	230 °C, 5 min
Injector Cond.:	Split, 280 °C
Detector:	FID, 280 °C
Carrier Gas:	Hydrogen, 4 psi

Note: This was performed by heated headspace analysis.

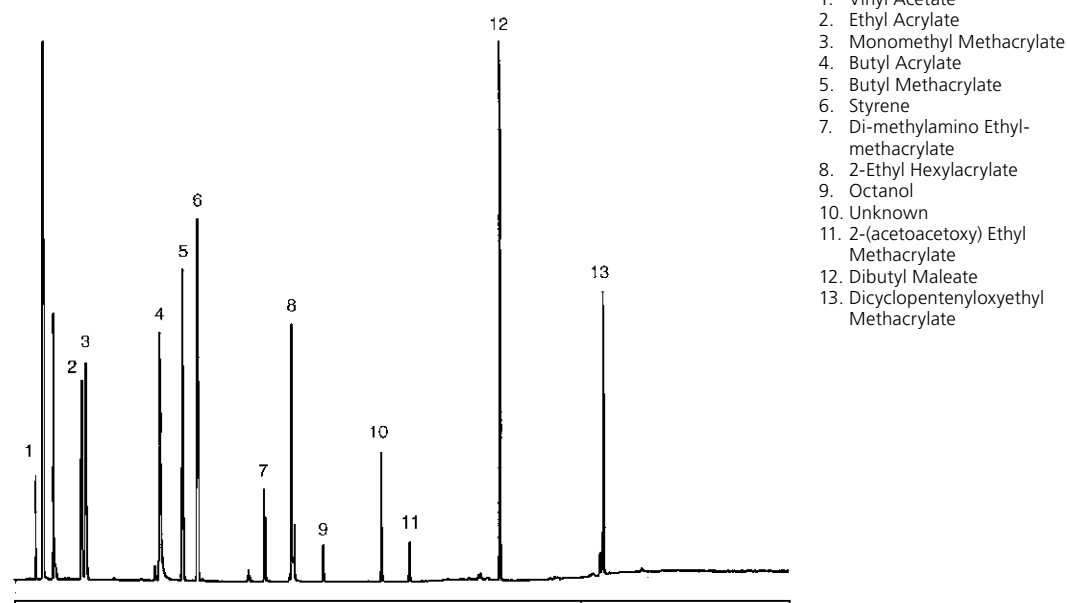

POL 05 | Pyrolysis of Styrene-isoprene Copolymer Pyrolysis of Polystyrene on BP1

Column Part No.:	054053
Phase:	BP1, 1.0 µm
Column:	25 m x 0.22 mm ID
Initial Temp.:	40 °C, 1 min
Rate:	10 °C/min
Final Temp.:	140 °C
Detector:	FID
Pyrolysis Temp.:	550 °C
Carrier Gas:	H ₂ 10 psi

Column Part No.:	054065
Phase:	BP1, 0.5 µm
Column:	25 m x 0.32 mm ID
Initial Temp.:	40 °C, 1 min
Rate:	10 °C/min
Final Temp.:	130 °C
Detector:	FID
Pyrolysis Temp.:	800 °C
Carrier Gas:	H ₂ , 5 psi



GC Columns and Applications

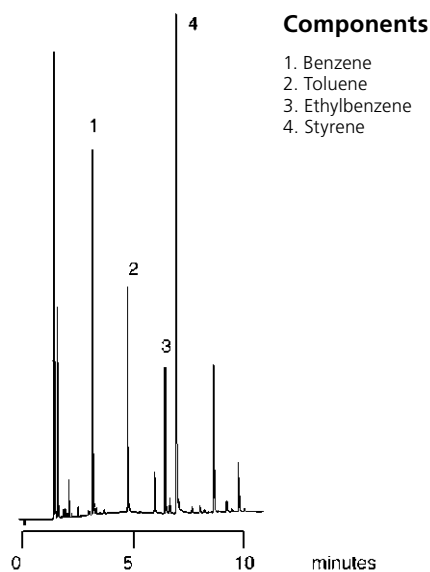
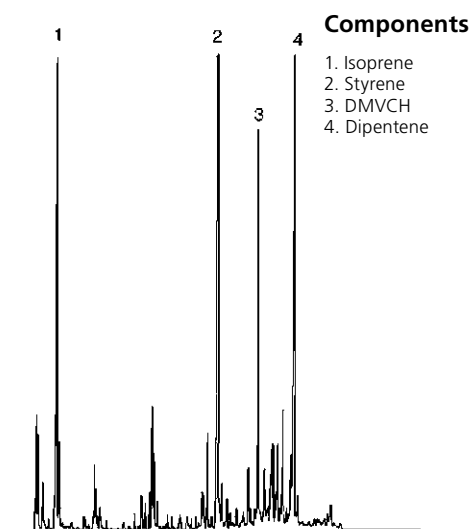

SOL 21 | Analysis of a Common Solvent Mixture on BP624

Column Part No.:	054832
Phase:	BP624, 1.8 µm film
Alcohol mix:	1000 ppm in Dimethyl Sulfoxide
Column:	30 m x 0.32 mm ID
Initial Temp:	32 °C, 9 min.
Rate:	30 °C/min to 190 °C
Final Temp:	190 °C, 0 min.
Detector Type:	FID
Carrier Gas:	He, 9.6 psi
Carrier Gas Flow:	2.2 mL/min.

Constant Flow:	On
Average Linear Velocity:	34 cm/sec at 32 °C
Injection Mode:	Split
Split Ratio:	100:1
Injection Volume:	0.2 µL
Injection Temperature:	250 °C
Autosampler:	No
Liner Type:	4 mm ID Double Taper Liner
Liner Part Number:	092018

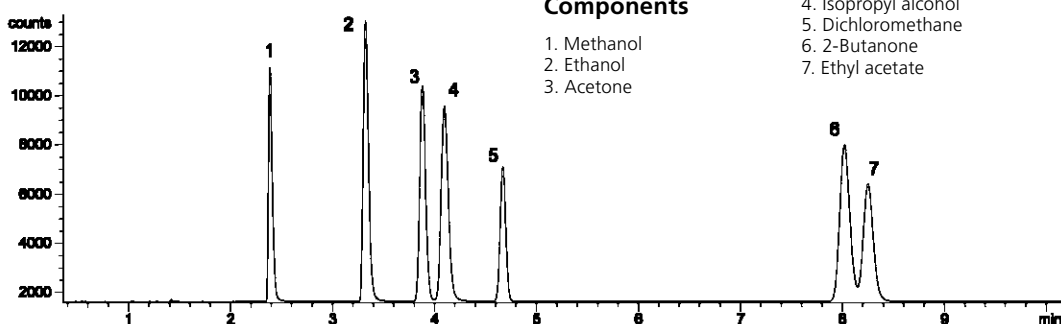



GC Columns and Applications

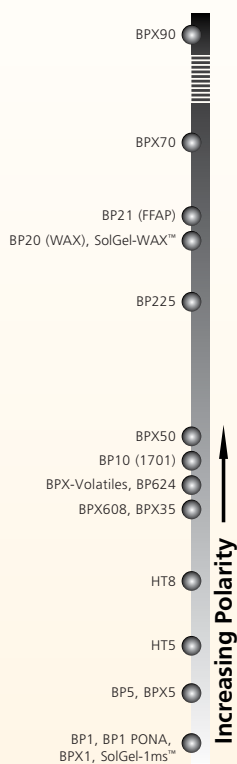

ENV 52 | Industrial Solvents on SolGel-WAX™

Column Part No.	054797		
Phase:	SolGel-WAX™, 0.5 µm film 30 m x 0.32 mm ID	Constant Flow:	On
Split / Splitless		Pressure:	8.4 psi
Injector Temp:	240 °C	Column Flow:	1.84 mL/min
Injection Volume:	0.1 µL	Linear Velocity:	30 cm/sec at 35 °C
Autosampler Syringe:	0.5 µL Removable Needle Part No. 000410	Initial Temp.:	35 °C
Septa:	Auto-Sep T™ Part No. 041882	Initial Time:	3 min
Injection Type:	Split	Rate 1:	15 °C/min
Purge On Time:	NA	Final Temp. 1:	230 °C
Purge On (Spilt) Vent:	150 mL/min	Hold Time:	4 min
Split Ratio:	83 to 1	Run Time:	20.00 min
Liner Type:	Single taper Part No. 092017	Detector Parameters	
Carrier Gas:	He	Detector Type:	FID at 270 °C

Sample Description: Industrial solvents mix, 25 to 50 ng per component on column

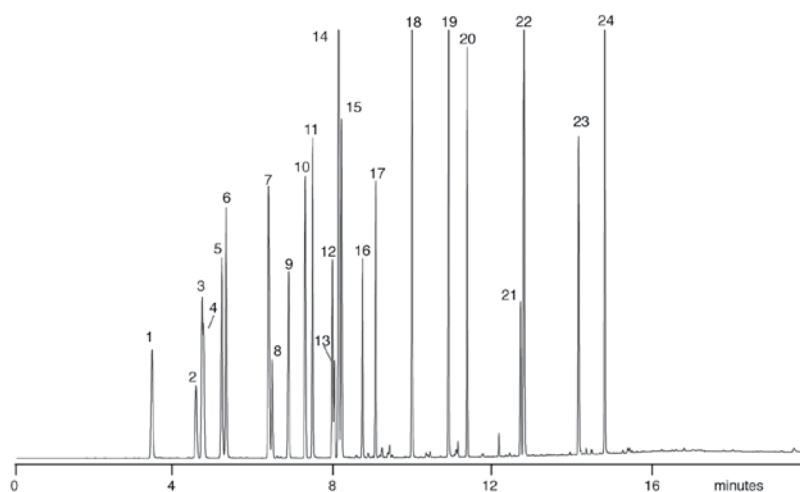

Components

1. Acetone
2. Ethyl acetate
3. Methyl ethyl ketone
4. Contaminant
5. iso-Propanol
6. Ethanol
7. Methyl isobutyl ketone
8. Toluene
9. Butyl acetate
10. iso-butanol
11. Propylene glycol monomethyl ether
12. n-Butanol
13. Ethyl benzene
14. p-Xylene
15. m-Xylene
16. o-Xylene
17. Butyl Cellosolve acetate
18. Cyclohexanone
19. Butyl Cellosolve
20. Butyl glycol acetate
21. Hexyl Cellosolve
22. Isophorone
23. Butyl Carbitol
24. Benzyl alcohol

SOL 04 | Acrylic Acid/Acrylamide Analysis on BP21

Column Part No.:	054473
Phase:	BP21, 0.5 µm film
Column:	12 m x 0.53 mm ID
Initial Temp:	75 °C, 0.5 min
Rate:	10 °C/min
Final Temp:	150 °C
Detector:	FID, 280 °C
Injection Mode:	On-Column
Carrier Gas:	He, 6 psi

Notes: When response of acrylic acid is low, removal of 30 cm from the front of the column will correct this loss. On-column injection is recommended or polymerization of acrylic acid may occur.

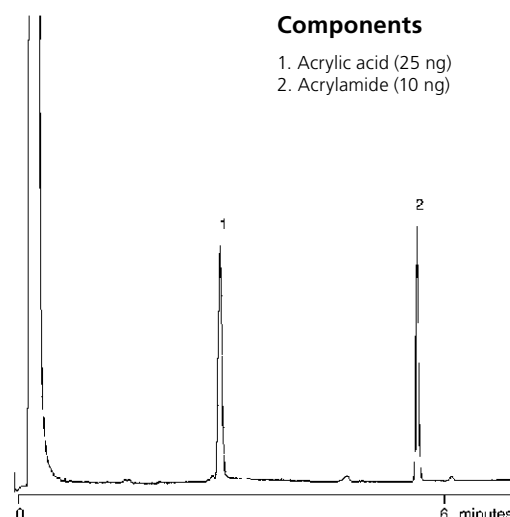

Components

1. Acrylic acid (25 ng)
2. Acrylamide (10 ng)

TP-0138-C | Analysis Of Polybrominated Diphenyl Ethers on BP1



GC Columns and Applications

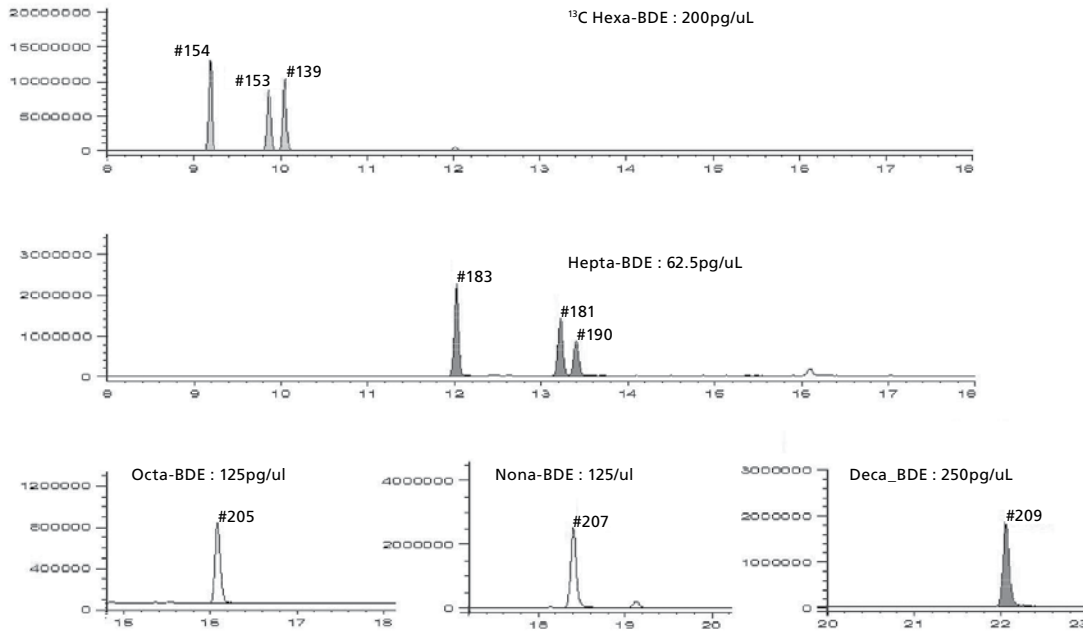

SGE would like to thank the Japan Food Research Centre for evaluating the BP1 column, SGE Japan and Chemicals Evaluation and Research Institute, Japan Toshiyuki KATAOKA, Masahiro AKIBA and Shinnichi KUDO.

TP-0138-C | Analysis Of Polybrominated Diphenyl Ethers on BPX5

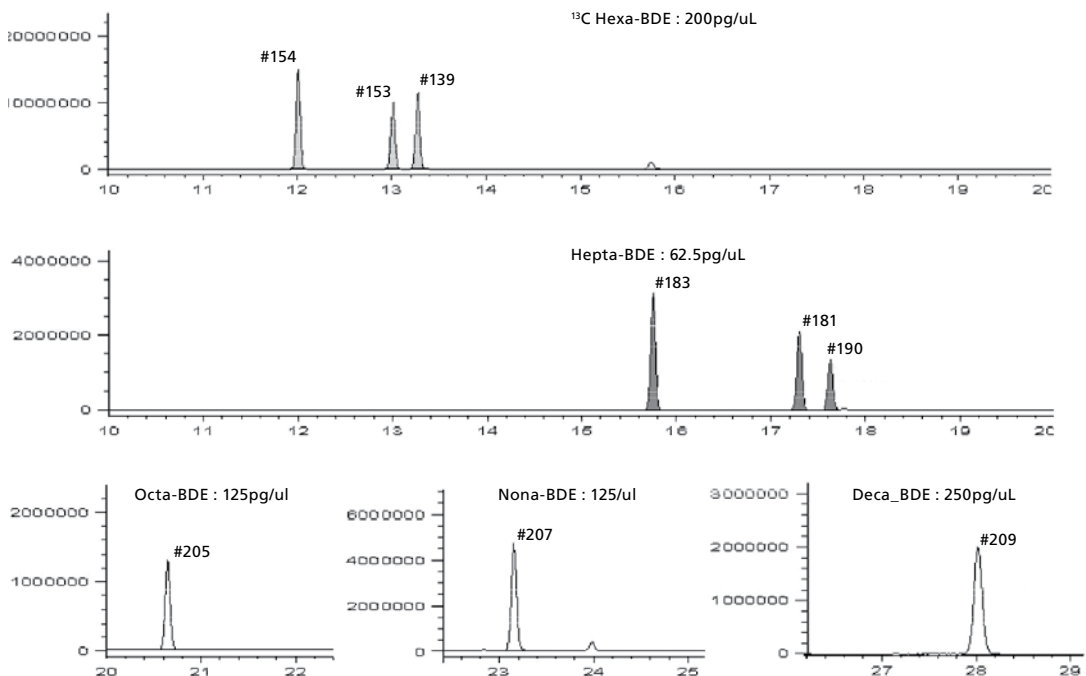

SGE would like to thank SGE Japan and Chemicals Evaluation and Research Institute, Japan Toshiyuki KATAOKA, Masahiro AKIBA and Shinnichi KUDO.



GC Columns and Applications

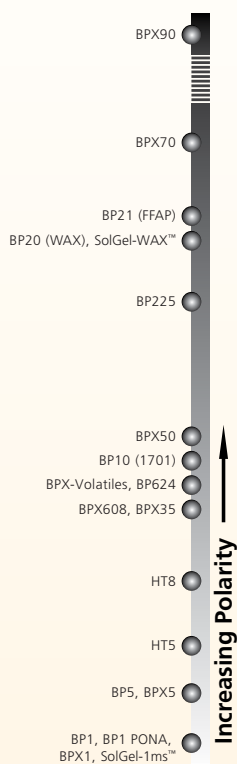

TP-0138-C | Analysis Of A Mixture Of Pentachlorobiphenyls on HT8-PCB

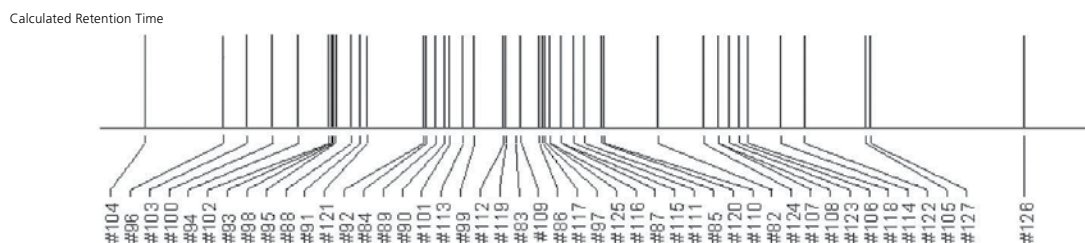
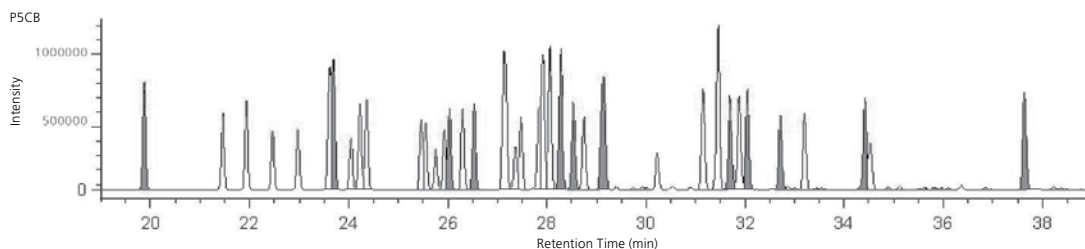

The separation of a mixture of pentachlorobiphenyls using an HT8-PCB column. Elution order calculated for the 5CBs from structure activity relationships based on coplanarity and confirmation, steric factors and electron density show a high correlation with experimental results.

SGE would like to thank T. Nakano, C. Matsumura and M. Tsurukawa at Hyogo Prefectural Institute of Public Health and Environmental Sciences, for providing the PCBs on HT8-PCB data.

TP-0138-C | Analysis Of A Mixture Of PBDD, PCDD And PBDF on BPX70

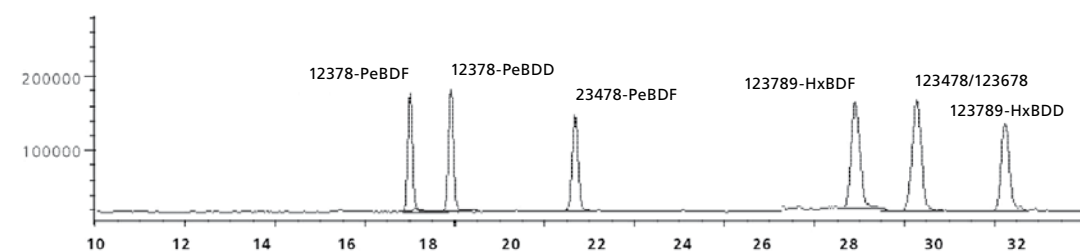
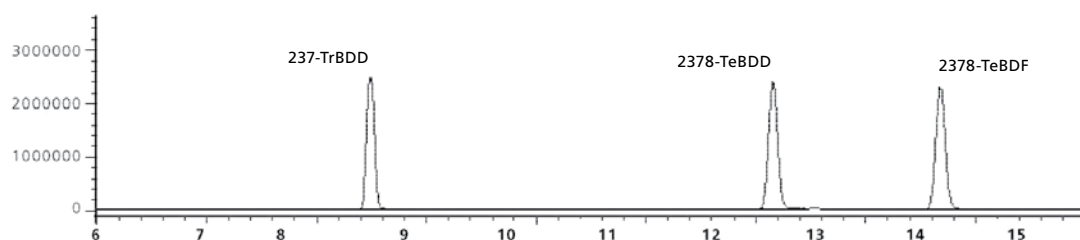

Figure 4. The separation of a mixture of PBDD and PBDF on a BPX70 column. The mixture was separated using the π - π interaction between the compounds and the cyano phase of the BPX70 column.

SGE would like to thank Toshiyuki Kataoka, Masahiro Akiba and Shinnichi Kudo of the Chemicals Evaluation and Research Institute, Japan, and SGE Japan, for providing the chromatograms of PBDEs on the ENV-5 and BPX70 columns.

PHA 14 | Analysis of Drugs of Abuse on BPX35

Column Part No.:	054711	Temp 2:	200 °C
Phase:	BPX35, 0.25 µm film	Rate 2:	7 °C/min
Column:	25 m x 0.22 mm ID	Temp 3:	295 °C
Initial Temp.:	80 °C	Rate 3:	20 °C/min
Rate 1:	15 °C/min	Final Temp.:	340 °C, 6 min



GC Columns and Applications

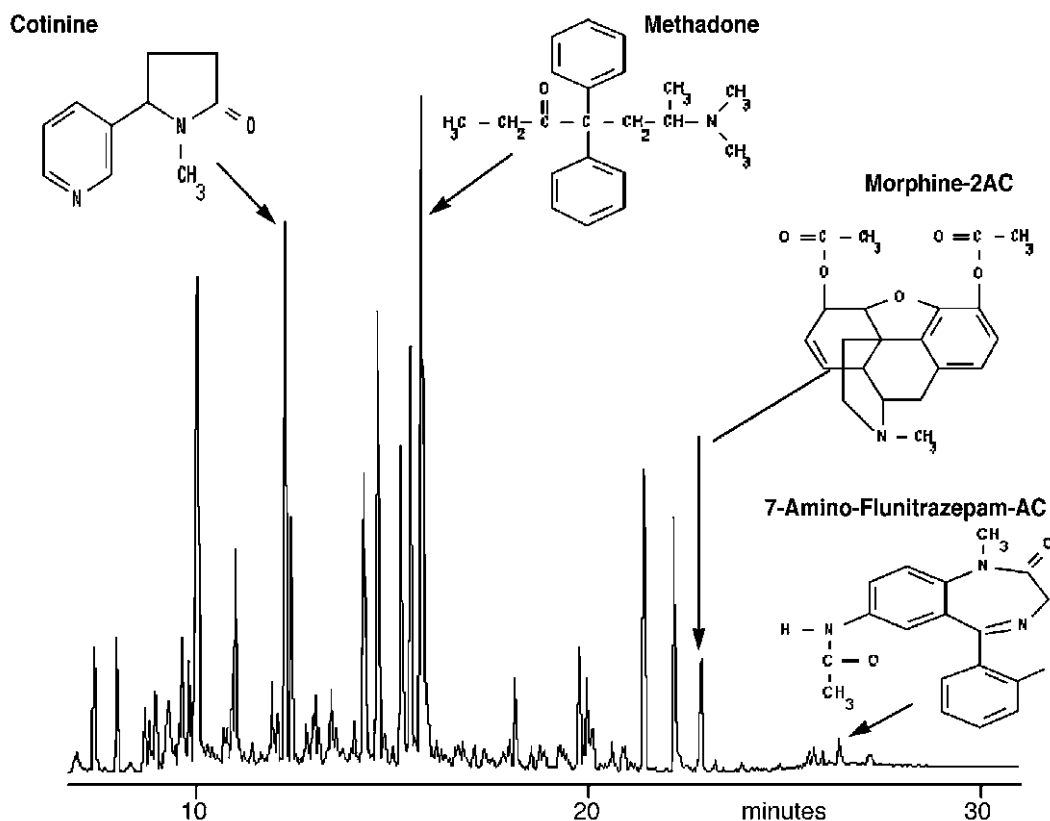

PHA 09 | Analysis of Tricyclic Antidepressants on BPX35

Column Part No.:	054711
Phase:	BPX35, 0.25 µm
Column:	25 m x 0.22 mm ID
Initial Temp.:	210 °C, 1 min
Rate:	5 °C/min
Final Temp:	280 °C
Carrier Gas:	Helium, 150 kpa
Injection Mode:	Split (20:1)
Detector:	FID, 380 °C

Note: BPX35 is a low bleed, chemically inert phase which allows trace analysis to occur.

Components

1. Amitriptyline
2. Trimipramine
3. Nortriptyline
4. Doxepin
5. Desipramine

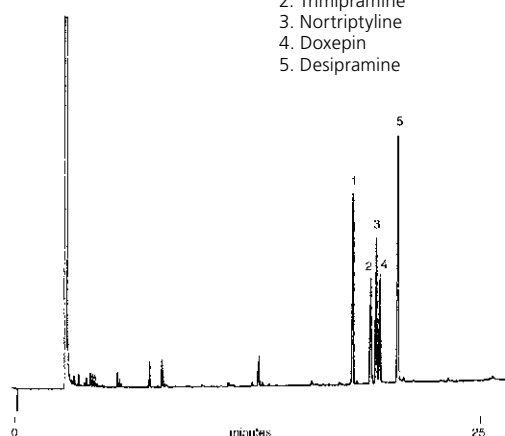



GC Columns and Applications

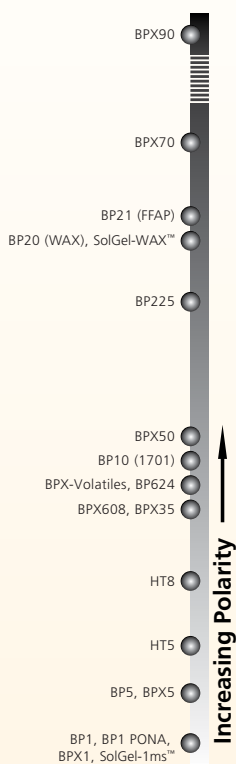

PHA 19 | Analysis of a Variety of Antidepressant and Anticonvulsant Drugs on BPX50

Column Part No.: 054751

Phase: BPX50, 0.25 µm film

Column: 30 m x 0.25 mm ID

Sample: 5-10 ppm in methanol

Initial Temp: 150 °C, 0.5 min

Rate 1: 10 °C/min to 180 °C

Rate 2: 1.5 °C/min to 220 °C

Rate 2: 30 °C/min to 260 °C

Final Temp: 260 °C, 5 min

Detector Type: FID

Detector Temp.: 320 °C

Carrier Gas: He, 25.7 psi

Carrier Gas Flow: 1.8 mL/min.

Constant Flow: On

Average Linear Velocity: 35 cm/sec at 40 °C

Injection Mode: Splitless

Purge on Time: 0.5 min

Purge on (Split) Vent Flow: 60 mL/min

Injection Volume: 1 µL

Injection Temperature: 250 °C

Liner Type: 4 mm ID Single Taper Liner

Liner Part Number: 092017

Full Scan / SIM: Full scan 45-450

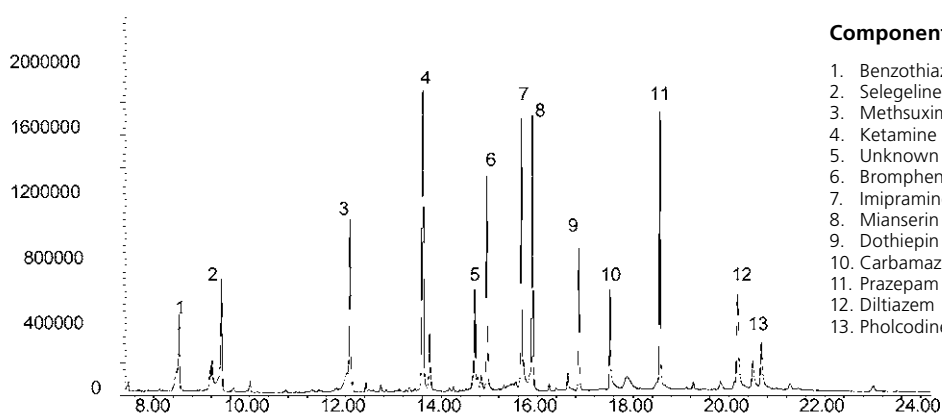
**Components**

1. Benzothiazole
2. Selegeline
3. Methsuximide
4. Ketamine
5. Unknown
6. Brompheniramine
7. Imipramine
8. Mianserin
9. Dothiepin
10. Carbamazepine
11. Prazepam
12. Diltiazem
13. Pholcodine

PHA 13 | Analysis of Blood Alcohol on BP20

Column Part No.: 054442

Phase: BP20, 1.0 µm film

Column: 25 m x 0.32 mm ID

Initial Temp: Isothermal, 60 °C

Detector: FID

Sensitivity: 64 x 10⁻¹² AFS

Injection Mode: Split

Note: The BP20 column allows the use of aqueous solutions.

Components

1. Acetone
2. Ethyl Acetate
3. Methanol
4. iso-Propanol
5. Ethanol
6. n-Propanol

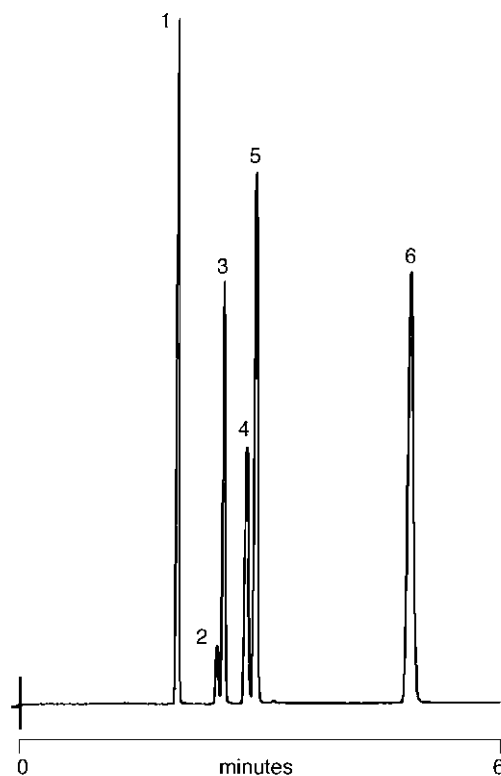

PHA 06 | Analysis of Basic Drug Screen on BPX5 (10-20 ng/component)

Column Part No.:	054131		
Phase:	BPX5, 1.0 µm	Final Temp.:	310 °C
Column:	25 m x 0.53 mm I.D.	Detector:	FID
Initial Temp.:	120 °C	Injector:	Split, 240 °C
Rate:	10 °C/min	Carrier Gas:	H ₂ , 2 psi

Note: The low bleed nature of the BPX5 allows trace analysis to be performed.



GC Columns and Applications

Components

1. Methamphetamine
2. Phendimetrazine
3. Phencyclidine
4. Mepivocaine
5. Methaqualone
6. Amitriptyline
7. Codeine
8. Diazepam
9. Fentanyl

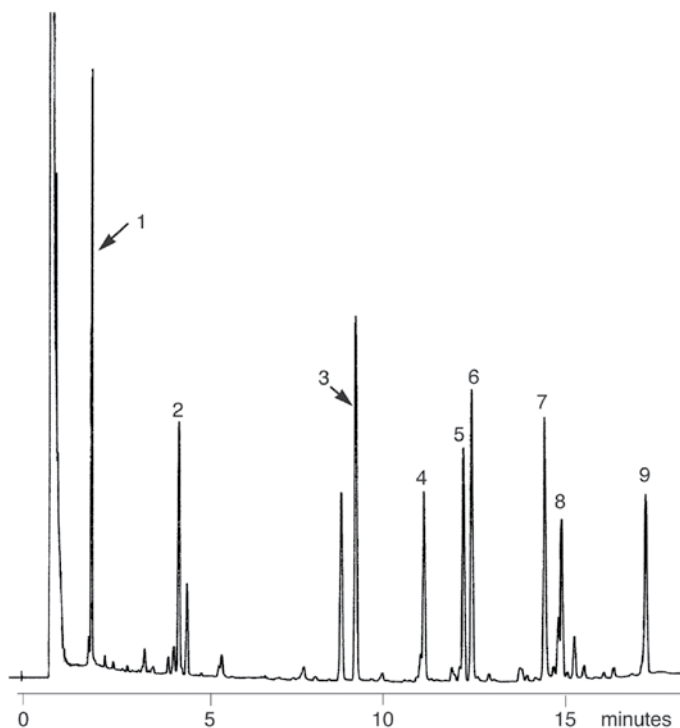

PHA 08 | Underivatized Steroid Analysis on BPX5

Column Part No.:	054113		
Phase:	BPX5, 0.25 µm	Final Temp.:	350 °C, 10 min
Column:	25 m x 0.22 mm ID	Detector:	FID
Initial Temp.:	180 °C	Sensitivity:	32 x 10 ⁻¹² AFS
Rate:	8 °C/min	Injection Mode:	Split
Carrier Gas:	H ₂ , 10 psi		

Note: The low bleed nature of the BPX5 allows trace analysis to be performed.

Components

1. Testosterone
2. Pregnenolone
3. Progesterone
4. Cholesterol

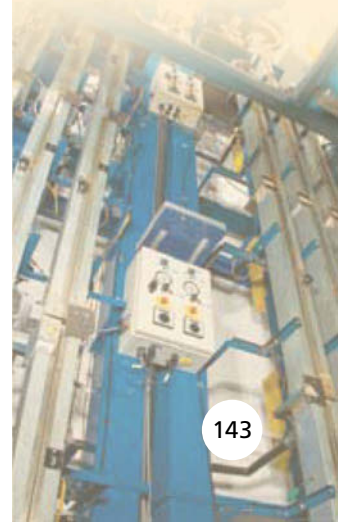
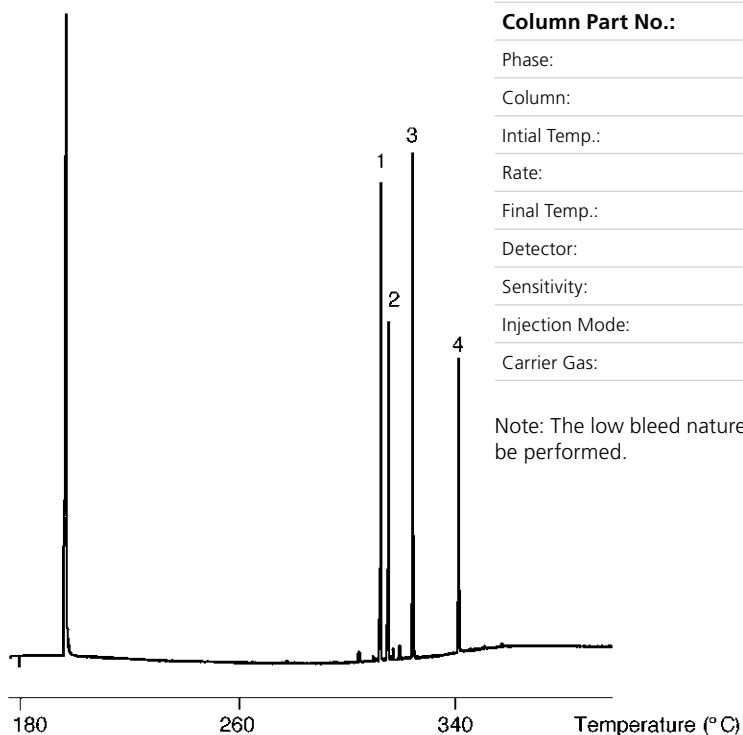



GC Columns and Applications

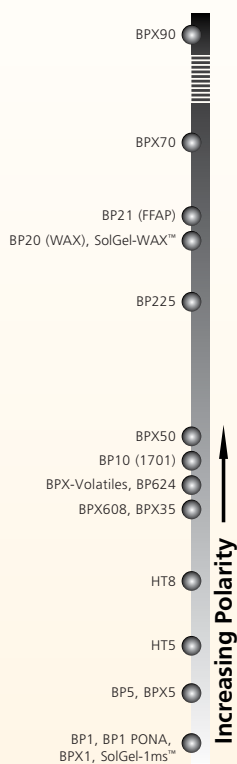

PHA 15 | Analysis of Horse Racing Test Mix on BPX5

Column Part No.:	054101
Phase:	BPX5, 0.25 µm film
Column:	30 m x 0.25 mm ID
Horse Racing standard*:	10 ppm in methanol
Initial Temp:	75 °C, 2 min
Rate 1:	15 °C/min to 300 °C
Rate 2:	20 °C/min to 320 °C
Final Temp:	320 °C, 8 min.
Detector Type:	Mass Spectrometer
Carrier Gas:	He, 14.5 psi
Carrier Gas Flow:	1.5 mL/min

Constant Flow:	On
Average Linear Velocity:	45 cm/sec at 75 °C
Injection Mode:	Splitless
Purge on Time:	0.5 min
Purge on (Split)	
Vent Flow:	60 mL/min
Injection Volume:	1 µL
Injection Temperature:	250 °C
Liner Type:	4 mm ID Double Taper Liner
Liner Part Number:	092018

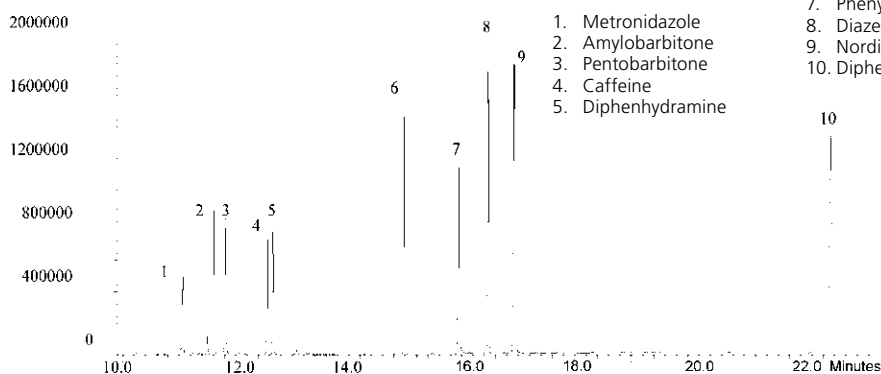
**Components**

- | | |
|--------------------|-------------------|
| 1. Metronidazole | 6. Trimipramine |
| 2. Amylobarbitone | 7. Phenytoin |
| 3. Pentobarbitone | 8. Diazepam |
| 4. Caffeine | 9. Nordiazepam |
| 5. Diphenhydramine | 10. Diphenoxylate |

PHA 03 | Analysis of Alkaloids on BP5

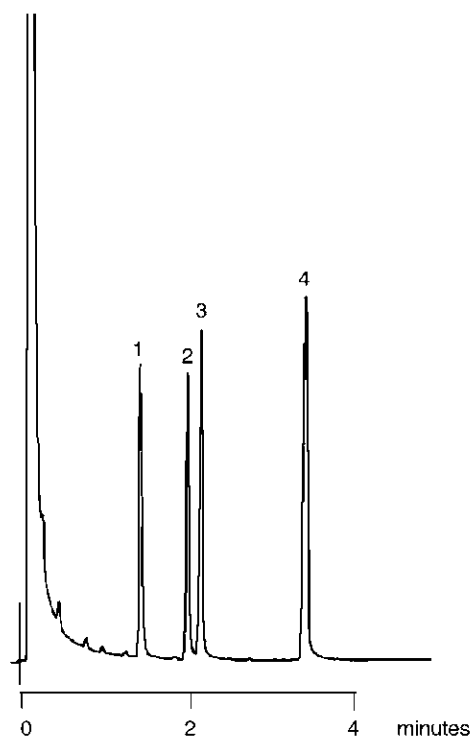

Column Part No.:	054198
Phase:	BP5, 1.0 µm film
Column:	25 m x 0.53 mm ID
Initial Temp.:	200 °C, 0 min
Rate:	25 °C/min
Final Temp:	300 °C, 0 min
Detector:	FID
Sensitivity:	128 x 10 ⁻¹² AFS
Injection Mode:	Split

Note: A 0.53 mm ID column can be used to screen samples rapidly.

Components

1. Cocaine
2. Codeine
3. Morphine
4. Quinine

PHA 10 | Underivatized Barbiturates on BP5

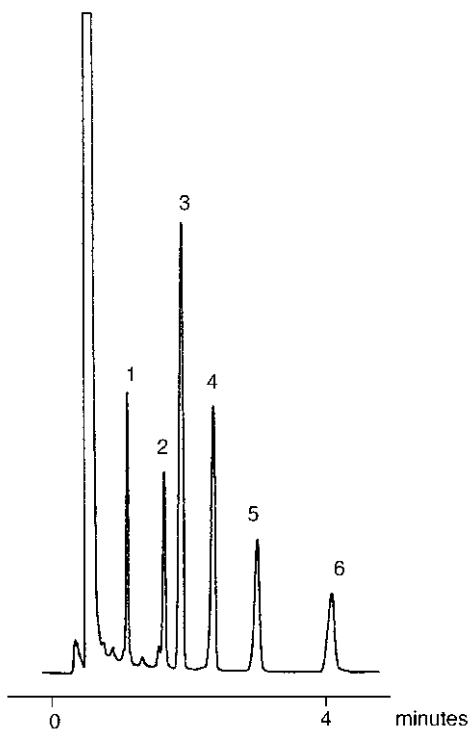

Column Part No.:	054197
Phase:	BP5, 1.0 µm
Column:	12 m x 0.53 mm I.D.
Temp:	195 °C
Carrier Gas:	Hydrogen
Carrier Flow:	10 mL/min
Injection Volume:	0.1 µL

Note: A 0.53 mm ID column can be used to screen samples rapidly.

Components

1. Barbital
2. Butabarbital
3. Amobarbital
4. Pentabarbital
5. Secobarbital
6. Hexabarbital



GC Columns and Applications

PHA 04 | Analysis of Sedatives/Hypnotics on BP1

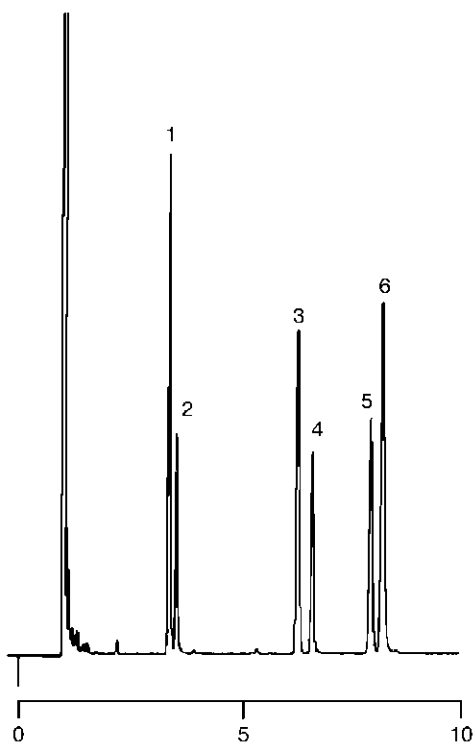

Column Part No.:	054087
Phase:	BP1, 1.0 µm film
Column:	25 m x 0.53 mm ID
Initial Temp.:	180 °C, 0 min
Rate:	10 °C/min
Final Temp.:	250 °C, 3 min
Detector:	FID
Sensitivity:	1024 x 10 ⁻¹² AFS
Injection Mode:	Split

Components

1. Allobarbital
2. Aprobarbital
3. Diphenhydramine
4. Mephobarbital
5. Methapyrilene
6. Chlorpheniramine

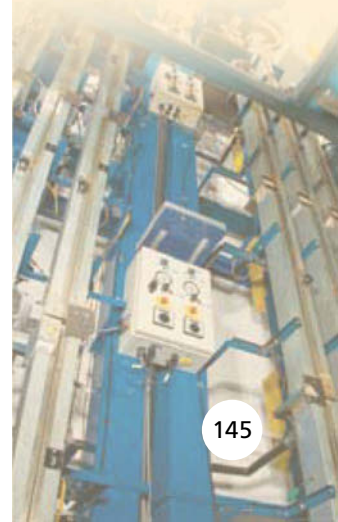



GC Columns and Applications

PHA 01 | Analysis of Acid/Neutral Drugs on BPX35

Column Part No.:	054711		
Phase:	BPX35, 0.25 µm	Final Temp.:	300 °C, 5 min
Column:	25 m x 0.22 mm ID	Carrier Gas:	He, 150 kpa
Initial Temp.:	100 °C, 1 min	Injection Mode:	Split, (20:1)
Rate:	10 °C/min	Detector:	FID, 380 °C

Note: BPX35 is a low bleed column with a maximum temperature of 360 °C. Very compatible with GC/MS systems.

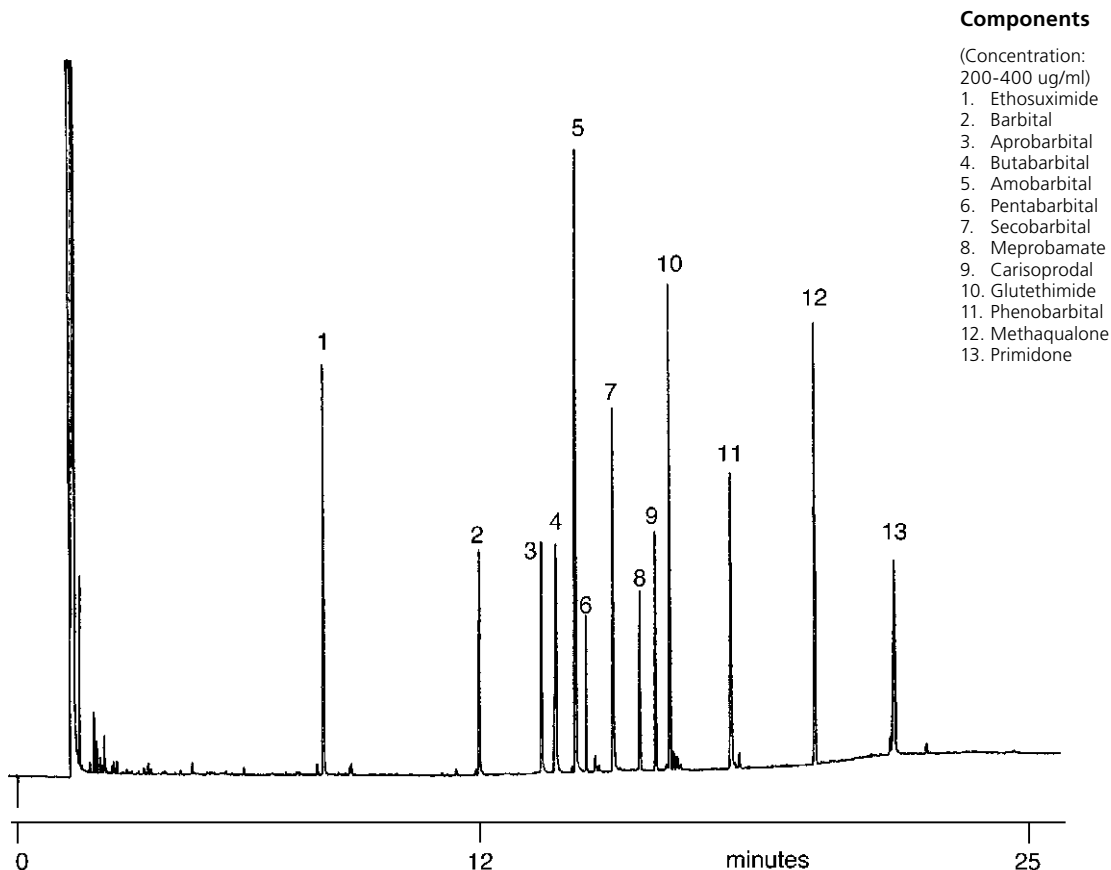
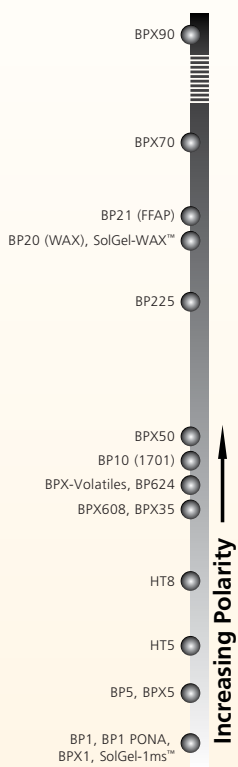

Components

- (Concentration: 200-400 ug/ml)
1. Ethosuximide
 2. Barbitol
 3. Aprobarital
 4. Butabarbitol
 5. Amobarbitol
 6. Pentabarbitol
 7. Secobarbitol
 8. Meprobamate
 9. Carisoprodol
 10. Glutethimide
 11. Phenobarbitol
 12. Methaqualone
 13. Primidone



GC Supplies

Injector to Detector	148-149
Septa	150-151
GC Inlet Liners:	
Enhanced Range	151-157
Inlet Liner Selection	151-157
Connections, Ferrules and Unions:	
Ferrules	158-161
SilTite™ FingerTite	159
Unions	161-164
Nuts for SGE Fittings	164-165
Gas Purifiers for GC	165-166
Instrument Quick Pick Guide:	
Agilent Technologies	167-170
PerkinElmer	170-172
Shimadzu	172-174
Thermo Scientific	175-177
Varian / Bruker	177-180
ATAS Optic Injectors	180

Your chromatography analysis does not end with the selection of the GC column! The combination of components selected for your instrument also make an important contribution to successful separations. SGE brings technology and chromatography expertise to everything the sample touches.

Injector to Detector – SGE Supplies for Sample Preparation,

SAMPLE PREPARATION - MEPS™

MEPS™ (Micro Extraction by Packed Sorbent) can be used in GC sample preparation where extraction of semi-volatile polar and apolar organic compounds from aqueous samples and organic extracts is required. For a detailed description of MEPS™ see pages 222-225.

SAMPLE INTRODUCTION - Syringes

SGE's involvement in all areas of Chromatography provides us with a unique understanding of customer's requirements enabling us to optimize syringe design for sample introduction.

All SGE syringes for both manual and autosampler use incorporate SGE's new Diamond Syringe Technology offering significantly improved levels of durability, clarity and accuracy. No other syringe range provides such brilliance! SGE has a comprehensive range of syringe options including plunger protection, removable or fixed needles, a range of needle gauge and length options as well as needle-tip style alternatives. For manual syringes see pages 35-40, for GC autosampler syringes by instrument see pages 43-47.

SAMPLE INTRODUCTION - Septa

The role of septa for GC analysis is key with many chromatographic problems caused as a result of inappropriate septa material or inappropriate handling of the septa.

Desired septa attributes:

- Must reliably seal against the carrier gas pressure in the inlet.
- Must be capable of being pierced by the syringe needle without pieces of the septa being deposited in the GC inlet system, which would be catastrophic to the chromatography.
- Must be capable of being pierced and resealed time after time.
- Must not be allowed to be contaminated or bleed material into the chromatographic system.

See pages 150-151 for SGE's septa range.

The following pages explain how each product type contributes to your analysis, and show the options SGE provides in Supplies' design, material and functionality.

Sample Introduction, Separation and Detection

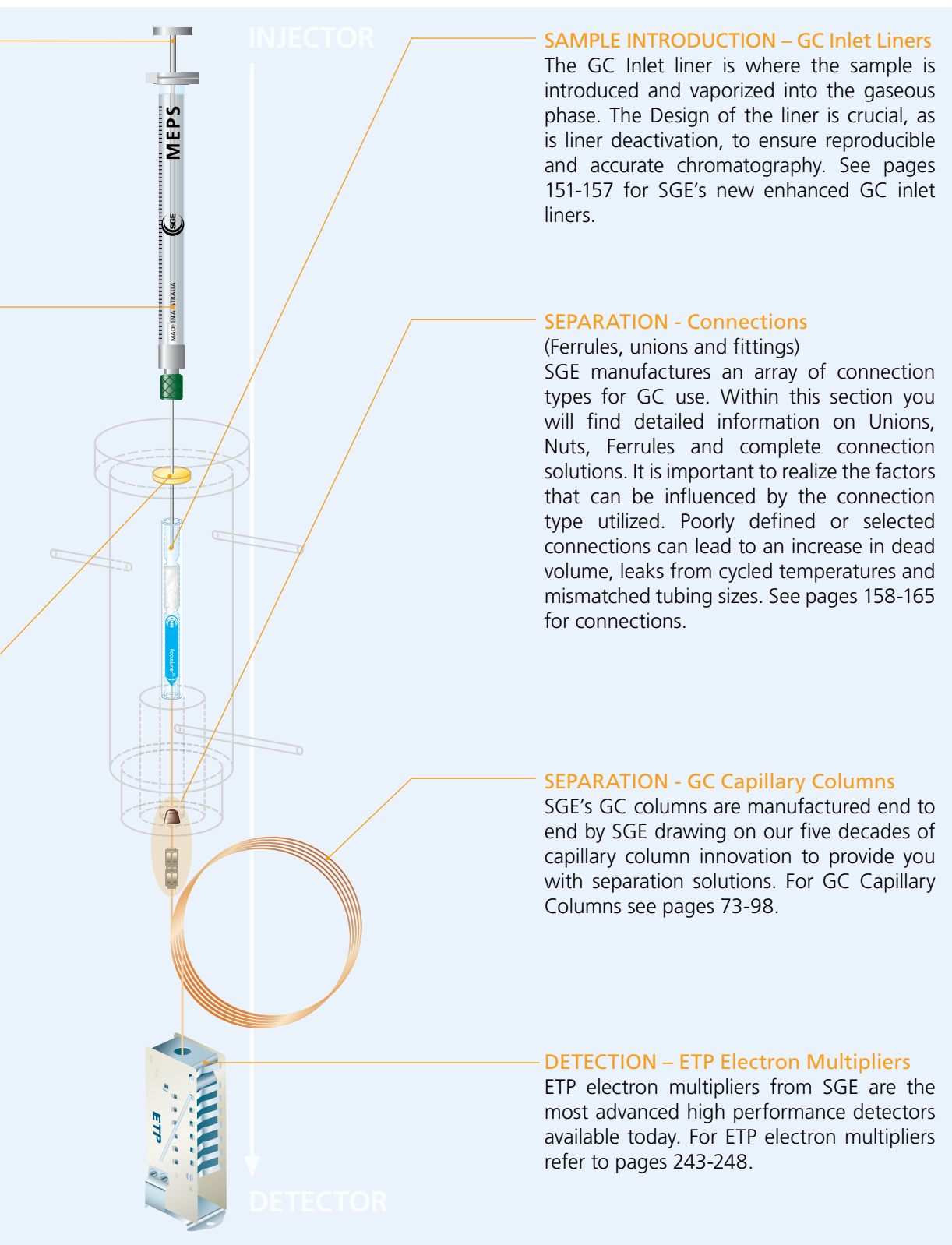

GC Supplies

Instrument Quick Pick Guide – for all GC supplies for your specific instrument, use the handy Instrument Quick Pick Guide on pages 167-180.

Due to the location of septa in the sample path, much attention has been focused on which material is the most appropriate to eliminate contamination, minimize bleed and ensure repeated sealing against the inlet. Comparisons between different septa materials in manufacturer's promotional material regularly show the bleed difference between Brands A, B and C. Whilst the formulation of the material is very important, without correct conditioning, handling

and storage; even the best materials can interfere with analysis results.

After preparation and conditioning, SGE's septa are immediately hermetically sealed into blister packs which prevent absorption from the environment. This delivers our customers a consistent product time after time. SGE recommends the septa only be released from the pack when they are ready to be used.

GC Supplies

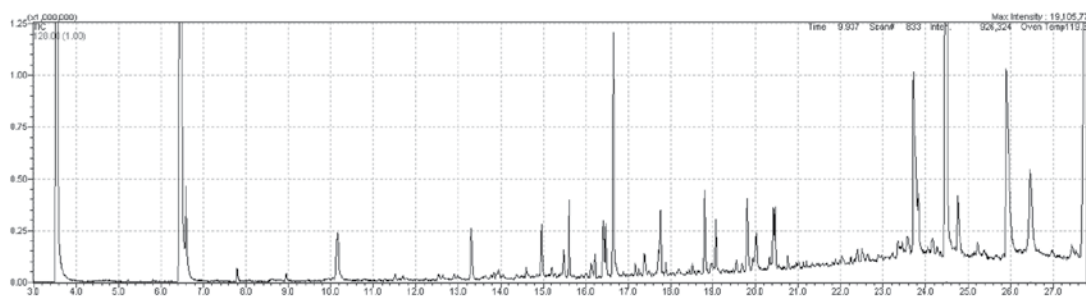
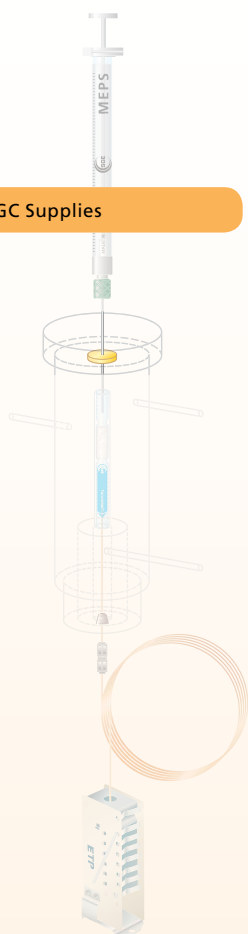

Type A: Septa bleed affecting chromatography.

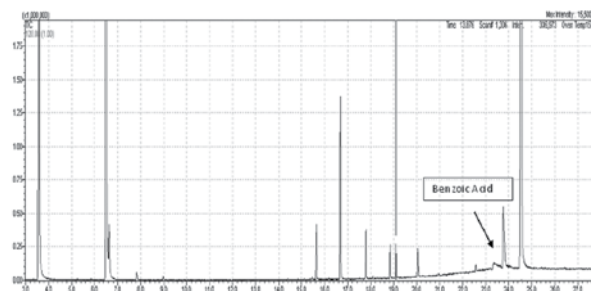

Type B: No septa bleed.

Expert Tip :

Keep septa in a hermetically sealed container until it is ready to be used. Pre-drilled septa used with a cone or dome tip syringe needle will give the longest life and reduce the risk of septa particles getting into the GC inlet liner which will have significant impact on the chromatography.



Material	Applications	Material	Durability	Resealing	Solvent Resistance	Tear Resistance	Maximum Injector Temperature
CS Septa	Low temperature applications	PTFE coated silicone	Good	Good	Excellent	Good	200 °C
TCS Septa	Medium/high temperature	PTFE coated triple layer silicone	Good	Very Good	Excellent	Very Good	280 °C
Auto-Sep™ Septa	High volume autosampler and manual use	Silicone	Excellent	Excellent	Excellent	Excellent	320 °C
Auto-Sep T™ Septa	Temperature programmable injectors, high volume autosamplers	PTFE coated silicone	Excellent	Excellent	Excellent	Excellent	350 °C
HT Septa	High temperature and low bleed	BTO silicone	Excellent	Excellent	Excellent	Excellent	400 °C
EC Septa	High temperature applications, high volume autosamplers	Silicone	Excellent	Excellent	Excellent	Excellent	400 °C
Enduro Blue Septa	For Shimadzu GC's only	High temperature silicone	Excellent	Excellent	Excellent	Excellent	350 °C

Septa are available in the following size formats:

Diameter	Material	Diameter	Material
4 mm	TCS Pre-drilled	10 mm	CS, TCS, TCS Pre-drilled
5 mm	CS, TCS Pre-drilled, HT Pre-drilled	11 mm	CS, TCS, TCS Pre-drilled, Auto Sep™, Auto Sep T™, HT, EC
6 mm	CS, TCS	11.5 mm	CS, TCS
7 mm	CS, TCS, TCS Pre-drilled, Auto Sep™, Auto Sep T™	12.5 mm	CS, TCS, Auto Sep T™, HT Pre-drilled
8 mm	CS, TCS, Auto Sep™	15 mm	CS
9 mm	CS, TCS, TCS Pre-drilled, Auto Sep™, HT, EC	17 mm	TCS, Auto Sep T™, HT, EC
9.5 mm	CS, TCS, TCS Pre-drilled, Auto Sep™, Auto Sep T™, HT, EC	Plug	Enduro Blue, HT, EC

To choose septa for your instrument find them in the Instrument Quick Pick Guide pages 167-180.

GC Supplies

GC Supplies | GC Inlet Liners

When gas chromatography with packed columns was first introduced in the 1950s, the process of sample introduction was relatively simple as the syringe needle easily fit within the bore of packed column tubing, therefore the sample being introduced into the column could be injected directly onto the packed phase. The advent of capillary columns for GC in the 1970s brought about significant improvements in column efficiency and separating power, but the drawback was the column ID no longer supported sample introduction directly onto the column. Thus, a new interface had to be created to allow the injection of the sample and its eventual transfer to the capillary column. This is what we refer to today as the injection port or GC inlet.

now available - split, splitless, programmable temperature vaporization (PTV) and on-column are the main examples. The most commonly used inlet is still the split/splitless injector. Each inlet has its own unique advantages and disadvantages and further details on injection techniques can be found on page 154.

The inlet liner prevents the sample contacting the metal walls of the injector block. Inlet liner geometry and packing materials enable the inlet liner to achieve greater heated surface area; this additional surface area can often improve sample vaporization. Conversely, choosing the wrong liner geometry can significantly decrease the reproducibility and quality of analysis.

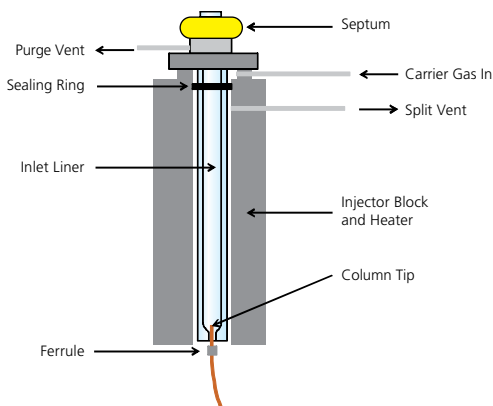

Split/Splitless Injector

The GC inlet functions as the interface of the sample syringe to the GC capillary column, where the sample is introduced, vaporized, mixed with carrier gas and transferred to the column. There are several types of inlets

The importance of correct liner selection

In a study by Kende et al (Chromatographia 2006) the performance of trace pesticide analysis with a number of inlet liner types were investigated: Single taper, Single taper with quartz wool and Double taper.

In combination with optimal injector temperature, injection volume, split vent time, head pressure and initial oven temperature, the liner design was found to significantly impact performance.

Optimization of injector parameters within a liner increased peak areas by 30-40%. However, even within a series of controlled

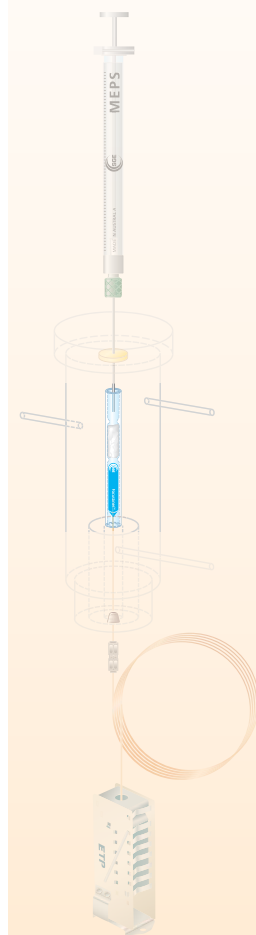

injector parameters there were significant differences between liner designs. Peak areas differed as much as 100% between single taper with wool and single taper. Overall, the correct choice of liner design and injector parameters can increase peak areas and reduce detection limits by up to 300%.

Since inlet liner selection is so important, and yet unfortunately frequently misunderstood or overlooked, SGE has made some changes to our inlet liner range to make selection simple optimize your results.

GC Supplies

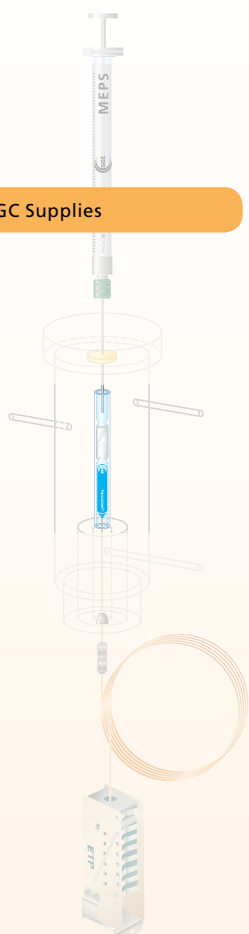

SGE New Lineup



SGE's new enhanced inlet liner range brings these benefits to gas chromatographers:

- **Easy to choose** Color coded by geometry to simplify your selection.
- **Easy to use** Contain o-rings so you're ready to go.
- **Confidence in your analysis** Certified deactivation gives you confidence in your analysis.



Easy to Choose

By drawing on our chromatography expertise, SGE has taken the complexity out of inlet liner selection.

To select an enhanced SGE inlet liner:

- Refer to the handy table below.
- Use the on-line inlet liner selection tool at www.sge.com/linertool
- Go to the Instrument Quick Pick Guide on pages 167-180.

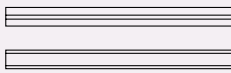
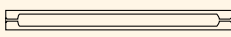
Color	Injection Technique	Sample Types	Liner Geometry	How the Geometry Works
Dark Green	Splitless	<ul style="list-style-type: none"> • Trace level analyses. • Active compounds. 	Taper / Gooseneck 	<ul style="list-style-type: none"> • A bottom taper focuses sample onto the head of the column and minimizes sample contact with metal parts of the inlet. • Remember – the addition of quartz wool to your inlet liner promotes mixing of analytes, aids the vaporization of liquid samples, works as a trap to collect non-volatile residue in the sample (i.e. protects capillary column from 'dirty' samples).
Blue	Split	<ul style="list-style-type: none"> • General purpose. • Concentrated samples. • Dirty samples. 	FocusLiner™ 	<ul style="list-style-type: none"> • Ensures quartz wool remains in the correct position in the liner. • Excellent reproducibility results from the wiping of the sample from the syringe needle and the prevention of droplet formation. • Minimizes high molecular weight discrimination.
Aqua	Splitless	<ul style="list-style-type: none"> • Trace level analyses. • Dirty sample. • Wide boiling point range. 	Taper FocusLiner™ 	<ul style="list-style-type: none"> • Bottom taper focuses sample onto the head of the column and minimizes contact with metal parts of the inlet. • Ensures quartz wool remains in the correct position in the liner. • Excellent reproducibility results from the wiping of the sample from the syringe needle and the prevention of droplet formation.
Orange	Direct	<ul style="list-style-type: none"> • Trace level analyses. • Active compounds. 	ConnecTite 	<ul style="list-style-type: none"> • ConnecTite liners facilitate maximum transfer of sample to GC column and inhibit sample degradation due to hot metal components inside inlet. • Systems equipped with electronic pressure control require a hole in the liner body to maintain system gas flows. • ConnecTite liners that have a hole near the bottom are best suited to analyses where a tailing solvent peak could affect early eluting compounds. ConnecTite liners with a hole at the top of the liner will improve your analysis with aqueous injections or where compounds of interest elute away from the solvent peak.

Color	Injection Technique	Sample Types	Liner Geometry	How the Geometry Works
Purple	Split Splitless	<ul style="list-style-type: none"> General purpose. Concentrated samples. Dirty samples (only if quartz wool is present) Gaseous samples (also Purge and Trap, Headspace). 	Straight 	<ul style="list-style-type: none"> Straight liners facilitate higher split flows. Narrow bore straight liners facilitate fast GC work. Small injection volumes of less than 0.5 µL are best used with a narrow bore. Narrow bore straight liners improve focussing of gaseous samples (purge, trap and headspace).
Yellow	Splitless LVI	<ul style="list-style-type: none"> Trace level analyses. Low boiling point compounds. Active compounds. 	Double Taper 	<ul style="list-style-type: none"> Bottom taper minimizes contact with metal parts of the inlet and focuses sample onto the head of the column. Top taper aids in minimizing sample flashback.
Grey	PTV LVI	<ul style="list-style-type: none"> Trace level analyses. Large volume injections. 	PTV/LVI 	<ul style="list-style-type: none"> PTV and LVI liners generally have sintered glass beads or powder to increase the surface area and trap non-volatile residue. PTV liners use baffles or a wisp of quartz wool to aid in vaporization of samples and retain droplets during low temperature injections. Side hole needles are recommended for these techniques to ensure effective distribution of sample within the liner.

SGE has tested the enamel used on our new inlet liners to confirm:

- The enamel does not affect the chromatography of the sample.
- The enamel does not deteriorate when in contact with strong solvents such as dichloromethane.
- The enamel is not affected by prolonged exposure to temperatures above 400 °C.

Indication of no interference of inlet liner print or packaging with Polynuclear Aromatic Hydrocarbons (PAH) Analysis on BPX50.

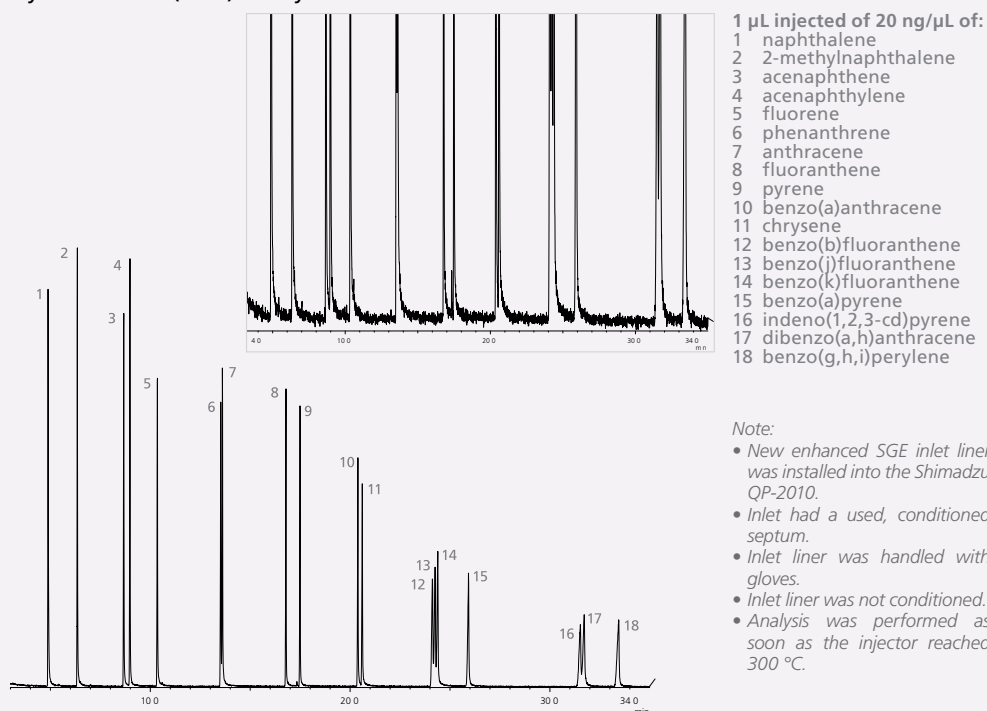

Note:

- New enhanced SGE inlet liner was installed into the Shimadzu QP-2010.
- Inlet had a used, conditioned septum.
- Inlet liner was handled with gloves.
- Inlet liner was not conditioned.
- Analysis was performed as soon as the injector reached 300 °C.

Inlet	300 °C
Transfer Line	300 °C
Initial Temp.	60 °C
Rate 1	35 °C/minute
	Temperature 120 °C
	Hold 0.5 minutes
Rate 2	8 °C/minute
	Temperature 200 °C
	Hold 0 minutes

Rate 3	11 °C/minute
	Temperature 270 °C
	Hold 0 minutes
Rate 4	2 °C/minute
	Temperature 300 °C
	Hold 0 minutes
Rate 5	40 °C/minute
	Temperature 320 °C
	Hold 4 minutes

MS – Source Temperature	260 °C
Scan	50-600 amu
High Pressure Injection (45psi)	Splitless for 1 minute
Constant Velocity	52 cm/sec

GC Supplies

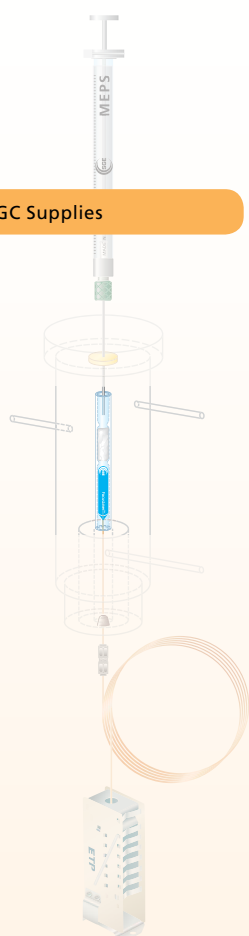

- Taper / Gooseneck
- FocusLiner™
- Taper Focus
- ConnecTite
- Straight
- Double Taper
- PTV/LVI

Variables of the Inlet Liner

Injection Technique

There are varied injection techniques for use dependent on sample type and analysis, an explanation of each is provided below. A significant proportion of chromatography

separation problems are caused by poor injection selection and technique. Both inlet liner geometry and injection technique are critical considerations.

Injection Technique	Recommended Geometry Type	Technique Description
Split Injection		<p>A portion of sample is split prior to loading onto the GC column. This is achieved by holding the split vent valve open during the loading process.</p> <p>The sample is vaporized in the inlet chamber, and is then swept through the liner and a portion of the vapor is loaded onto the GC column. The remainder (typically the majority of sample vapor) flows past the column entrance and out of the split vent.</p> <p>The flow through the liner is proportional to the split ratio that is set for the injection parameters. For instance, a 50:1 split ratio means one portion of sample will be transferred to the GC column for roughly every 50 parts that are sent out the split vent. If the GC column flow is set for 1 mL/min, the flow through the liner will be approximately 51mL/min. If we assume an internal liner volume of 1mL and a flow rate of 51mL/min through that liner, it will take approximately 1.2 seconds to clear the sample vapor from the liner.</p>
Splitless Injection		<p>Splitless injection is similar to a split injection since the same hardware is used however, unlike split injection, during the sample vaporization and loading, the Split Vent Valve remains closed for some period of time. This is referred to as the Splitless Hold Time and is typically 15-60 seconds in duration. This allows a maximum amount of sample to transfer to the GC column instead of being lost out the split vent. Once the loading step is complete, the split vent valve is opened and the remaining sample is swept out. It is very important that the splitless hold time be optimized for your analytes. If the split vent is opened too early, unvaporized sample may be purged from the inlet and not transferred to the column. If it is held too long, it can lead to excess solvent transfer and peak tailing.</p> <p>An advantage of splitless techniques is that the sample residence time within the liner is typically much longer than that of a split injection. Therefore higher molecular weight compounds have more time to achieve adequate vaporization and the discrimination effects that are often seen with split injections are reduced.</p>
Direct Injection		<p>Direct injection enables a nearly complete transfer of sample vapor to the GC column. Inlet liner geometry can be critical for complete sample transfer, see ConnecTite inlet liners in previous table and refer to 'How Geometry Works'.</p>
Programmable Temperature Vaporization (PTV)		<p>PTV injectors are unique in that they allow sample to be injected at cooler temperatures and then heated to vaporize and ultimately transfer to the GC column.</p> <p>This technique can also function like a pseudo large volume injection technique, in that a large volume of sample can be introduced into the injector at a cooler temperature, the sample can be de-solvated, then rapidly heated to sweep the analytes of interest onto the GC column. This increases sensitivity and lowers detection limits while minimizing the effects of excessive solvent in the system. The low initial temperature also helps protect heat sensitive compounds that might otherwise degrade in a flash vaporization technique.</p>

Inlet Liner Packing

Many liner designs include deactivated quartz wool packing, some of the reasons for this are:

- Provides additional surface area for complete volatilization of the sample to minimize sample discrimination.
- Traps non-volatile components and septum particles from reaching the column.
- Wipes any sample from the syringe needle, thereby increasing reproducibility and preventing sample residue build-up at the septum.

The position of the quartz wool in the inlet liner is critical. The quartz wool is normally present in the inlet liner to mix and homogenize the vapor prior to splitting and entering the column. Quartz wool is often used at the bottom of liners (just above the column) to trap non-volatile contaminants and septum particles from entering the column. This is also an ideal placement when polar solvents are used. More importantly, however, is the location of the quartz wool when used in the needle wipe. At the point of injection the needle tip must penetrate the quartz wool to maximize vaporization of the sample and to wipe any droplets that form on the needle tip, before removal from the injection port. Unfortunately, there is no guarantee that once the liner is installed in the injector, the quartz wool plug will stay in the correct position. SGE developed the FocusLiner™ to specifically overcome this problem.

SGE FocusLiner™

The unique SGE FocusLiner™ uses a simple but effective design to hold the quartz wool in the correct position by means of two tapered sections in the liner (Figure 2 and 3). The tapered sections are located to ensure that the needle tip penetrates the secured quartz wool plug wiping any residual liquid sample from

the needle tip while providing sufficient surface area for volatilization of the liquid sample. Current liner designs that utilize quartz wool to improve vaporization are frequently positioned incorrectly. Compounding the problem, the unsecured quartz wool plug can be easily dislodged by repeated injections. Each insertion of the needle tip can progressively move the plug until no further contact is made. Dislodging the plug can also occur through a sudden change in inlet pressure. For instance, removing the column from the injector or changing the septum can cause a sudden pressure change in the injector resulting in the movement of the plug.

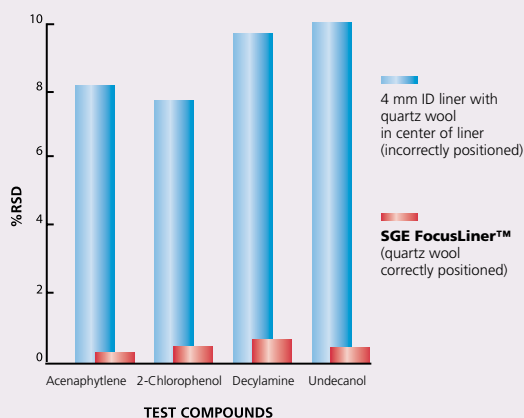

A Relative Standard Deviation (RSD) of 5-10% is common for a straight through liner. With the SGE FocusLiner™, a RSD of less than 1% using external standard calibration is easily achievable showing the effectiveness of the secured quartz wool.

FocusLiner™



Figure 2
The two tapered sections secure the quartz wool plug effectively wiping the needle tip during injection. This results in improved reproducibility.

Conventional Liners



Figure 3a
Quartz wool plug is in the position to wipe needle tip.

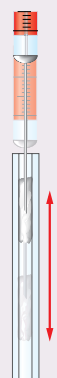

Figure 3b.
Quartz wool plug can be removed in either direction preventing the needle wiping or sample vaporization processes.

Temperature

One of the most important objectives in reproducible chromatography is the optimization of the inlet system to achieve complete, homogenous, and reproducible vaporization of the injected sample and appropriate temperature selection is critical to achieve the vaporization.

The inlet should be heated to a high enough temperature in order to achieve a thorough vaporization of the introduced sample but not so high that it leads to

GC Supplies

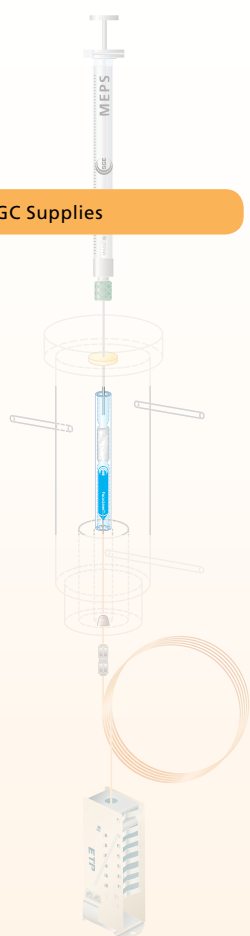

sample degradation (e.g. breakdown of thermally labile compounds). Other issues with the temperature being too high include discrimination – this is where the vaporization of the sample changes from injection to injection, or if some compounds are vaporized to a lesser extent than others. Discrimination can have a negative effect on run-to-run reproducibility.

Inlet Liner Volume

The purpose of the injection port is to allow the introduction of a sample into the gas chromatograph in a reproducible manner. The vaporized sample should be a true representation of the liquid sample and, unless specifically desired, should be injected without chemical change. The elevated temperatures used in the inlet vaporize the liquid sample to a gas for transfer to the head of the column. This phase transition is accompanied by a very significant volume change. The volume of the resulting vapor must be small enough to fit within the volume of the liner, specifically in splitless modes. If the vapor volume exceeds the liner's inner volume, that will cause overflow of the sample vapor from the liner. This is often referred to as flashback. Flashback typically results in contamination of the inlet system which in turn leads to carryover (ghost peaks) and poor run-to-run reproducibility.

One of the disadvantages of the splitless injection technique is that it is susceptible to flashback. Due to the slower gas flows through the inlet liner and increased sample vaporization (due to increased residence time) flashback becomes more likely. There are several ways to minimize flashback. The easiest is to know the internal liner volume and sample (solvent) expansion volumes.

There are several calculators on the internet that can help facilitate these calculations using these formulae:

Liner Volume Calculation

$$\text{Volume} = \text{Length} \times \pi r^2$$

$$\text{Expansion Volume } V = nRT/P$$

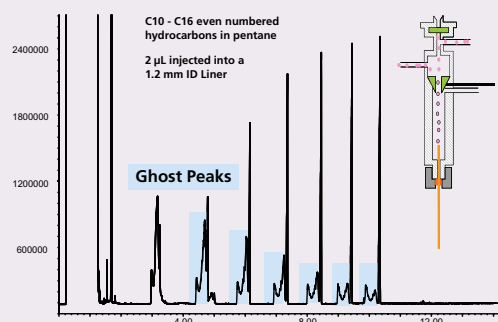

Flashback

The ideal conditions are for vapor volumes to be kept below 70-80 % of the liner's inner volume, as for splitless injections. Common splitless injectors today have a function known as 'pulsed splitless' mode. In this mode, the head pressure of the inlet system is increased during the injection process. This increased head pressure helps contain the sample vapor within the liner volume and inhibits the sample from flashing back into the system gas lines.

Sample Type

For information on sample types see the GC method development section pages 250-253.

Easy to Use

SGE's enhanced inlet liners now come as a new, complete, packaged solution:

- 1, 5 and 25 packs.
- Complete with instrument appropriate o-rings or sealing rings.
- Each pack supplied with quality assurance test results.
- Color coded instrument stickers to identify which inlet liner type is in your instrument.
- SGE blister packs are now perforated enabling easy division of the 5 and 25 packs while maintaining blister integrity.



- 25 packs come in a re-usable container, with a range of attractive designs, that will be handy around the lab.

GC Supplies

Confidence In Your Analysis

SGE standard inlet liner deactivation

SGE currently tests every batch of inlet liners for activity using the EPA 8081B method. This standard method ensures

that each batch of inlet liners has less than 3 % Endrin breakdown. Now, SGE is validating this quality assurance by including a batch certificate with every pack.

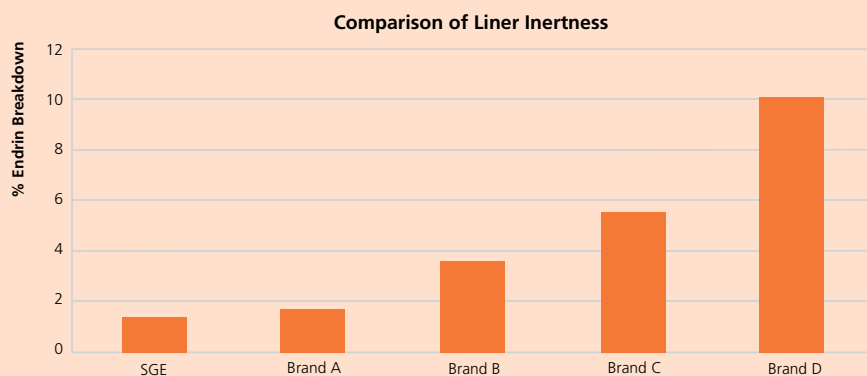

SGE has compared the Endrin Breakdown activity against a wide range of competitors in the industry.

When deactivation REALLY matters

Single pack deactivation certification options:

- Sometimes there is a need for fully traceable inlet liner certification. Customers who are ISO accredited or follow GLP will benefit from SGE's certified single packs. Add CERT when ordering.
- MS ready liners in single packs conditioned and MS tested post deactivation so they are ready for use straight out of the pack. Add MS when ordering.

For SGE inlet liner product listings, see the Instrument Quick Pick Guide on pages 167-180.

SGE manufactures an array of connection types for GC use. Within this section you will find detailed information on Unions, Nuts, Ferrules and complete connection solutions. It is important to realize the factors that can be influenced by the connection type used. Poorly defined or selected connections

can lead to an increase in dead volume, leaks from cycled temperatures and mismatched tubing sizes. Where possible, SGE recommends FingerTite™ solutions that eliminate the need for wrenches or other tools in your system.

Ferrules

When choosing ferrules ensure you consider the following:

- 1) Which material best suits your application?
- 2) What connection type do you want?

The following selection tables will assist with your decision.

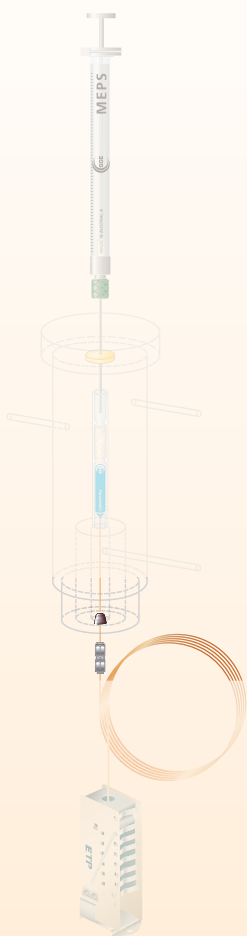

Ferrule Material Type	Graphite	Graphite Vespel®	SilTite™ Metal
Features	<ul style="list-style-type: none"> • Easy to use. • Forms a stable seal. • Soft material. • Porous to oxygen. • Can be reused. • Forms a soft grip with capillary column. • Low emissions. 	<ul style="list-style-type: none"> • A composite of graphite and Vespel®. • Mechanically robust. • Hard material, long lifetime. • Forms a strong grip with capillary column. • Cannot be reused with another capillary column. • Requires re-tightening. 	<ul style="list-style-type: none"> • Specifically developed to overcome the problems associated with the use of 100% graphite and composite ferrules. • Strong seal on capillary columns. • Leak free - The ferrule and nut expand and contract at the same rate eliminating any chance of leaks with temperature cycling. • Nut does not need re-tightening after initial temperature cycles.
Suitable uses	<ul style="list-style-type: none"> • Column to injector connection. • Non-mass spectrometer detectors (FID, ECD, TCD and NPD). 	<ul style="list-style-type: none"> • MS interfaces, - although even with a good seal will leak air compared to SilTite™ ferrules. 	<ul style="list-style-type: none"> • Ideal for MS interfaces due to leak free seal.
Not suitable for	<ul style="list-style-type: none"> • Porous to oxygen. Therefore unsuitable for connecting columns to mass spectrometers. 	<ul style="list-style-type: none"> • High temperature applications. 	
Risks	<ul style="list-style-type: none"> • Can leave residue inside your column. • Can extrude into the injector or detector if it is over-tightened. 	<ul style="list-style-type: none"> • If not re-tightened after installation and temperature cycles of the GC, air may enter the column or detector decreasing sensitivity of the analysis and possibly degrading the column as well as components of the system. 	<ul style="list-style-type: none"> • Over-tightening of the seal can introduce leaks into the system. Follow the recommended installation instructions to avoid this problem. • For a leak free seal every time choose SilTite™ FingerTite connections.
Operating Temperature	Upper limit of 450 °C	Upper limit of 325 °C	No temperature limit in GC use.

SilTite™ FingerTite – The Smart Alternative

SilTite™ FingerTite is the next generation ferrule system for gas chromatography systems providing these important benefits:

- Easy to install.
- Reliable, leak-free seal.
- Cannot be over-tightened.
- No tools required.

SilTite™ FingerTite has been developed with the unique, leak and air free properties of SilTite™ ferrules, resulting in superior air tightness to reduce background noise in sensitive MS applications so you can use them with confidence.

SGE SilTite™ ferrules and nuts are manufactured from stainless steel. SilTite™ ferrules MUST be used with SilTite™ nuts in the correct position on the capillary column. Since inlet, detector and MS transfer lines are also made of stainless steel, the thermal expansions of all connecting parts are the same. This alleviates the problem with seating of graphite/Vespel® ferrules where they need to be tightened after several GC temperature cycles before a perfect seal is finally attained. The SilTite™ ferrules are initially sold as a kit with ferrules and matching nuts.



SilTite™ FingerTite Starter Kits by Instrument

Each starter kit includes all the parts necessary to convert one GC or GC/MS system (one injector and one detector) to the SilTite™ FingerTite system suitable for installing 0.1 – 0.25 mm ID capillary columns. In addition there are five matching SilTite™ FingerTite nuts, 10 x 0.4 mm ID SilTite™ FingerTite ferrules and a ferrule install tool which allows you to seat the ferrule in the correct position on the capillary column. Please note normal extended nuts cannot be used with SilTite™ ferrules. The use of SilTite™ FingerTite system requires that the inlet and detector end of the GC or GCMS must be reconfigured with the appropriate kit from SGE. After the system is reconfigured, only one nut and one ferrule type is needed for all GC or GCMS systems. The Smart Alternative!

For your GC instrument solution with SilTite™ FingerTite use the Instrument Quick Pick Guide on pages 167-180.



Part No. 073610

Expert Tip :

Can I reuse the SilTite™ FingerTite ferrules?

Once the SilTite™ FingerTite ferrule is crimped onto the tubing using the ferrule installation tool, the fitting is permanent. However, the column can be removed and reinserted multiple times without tools.



Expert Tip :

Can I touch the nut even when the oven is at 200 °C?

No - the nut will be at the oven temperature so it will be too hot to touch. However, the nut is designed to dissipate the heat from the injector/detector/transfer line, so that when the oven is cool you can change the column without waiting for the injector/detector to cool down. For Mass Spectrometers always follow the manufacturer's recommendations to vent the system.



Expert Tip :

Can I break my column if I over-tighten the nut?

No - with the SilTite™ FingerTite system you cannot generate enough force with your fingers to break the column. Never use pliers or any other tool on the nut or you will possibly damage the Adaptor as well as break the column.



Standard SGE Ferrule Solutions

GC Supplies

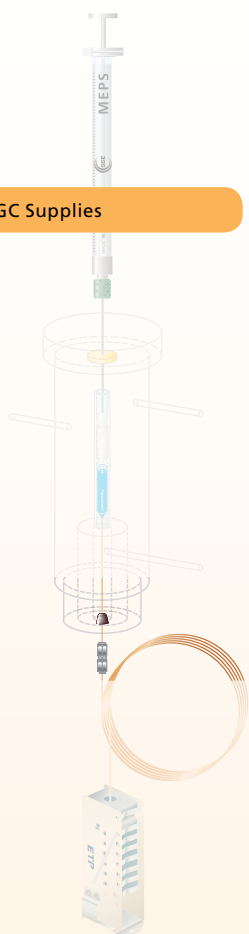





Ferrule Style	Hole ID	100% Graphite	15% Graphite / 85% Vespel®
1/16" Fitting Specifications – all ferrules supplied in packets of 10			
Straight (hole ID matches the nominal size of the fitting)	1/16"	072623	072657
Sealing Ring	1/16"	0726520	072653
Reducing Ferrule (hole ID smaller than the nominal size of fittings)	0.2 mm	-	0726632
	0.3 mm	-	072659
	0.4 mm	-	072663
	0.5 mm	072627	072654
	0.8 mm	072626	072655
	0.9 mm	-	072658
Reducing Ferrule - Short	1.0 mm	072625	072656
	0.3 mm	-	073107
	0.4 mm	-	073109
	0.5 mm	072610	073111
	0.8 mm	072608	073113
2-Hole Ferrule	1.0 mm	072607	-
	1.2 mm	072606	-
	2 x 0.3 mm	-	072660
	2 x 0.4 mm	-	072662
	2 x 0.5 mm	-	072664
	0.5 and 0.3 mm	-	0726640
3-Hole Ferrule	0.4 and 0.3 mm	-	0726641
	0.5 and 0.4 mm	-	0726642
	3 x 0.3 mm	-	0726650
No-Hole Ferrule - Blank	3 x 0.4 mm	-	072665
	No hole	-	072661
No-Hole Ferrule - Short and Blank	No hole	-	073105
1/8" Fitting Specifications – all ferrules supplied in packets of 10			
Straight (hole ID matches the nominal size of the fitting)	1/8"	072622	072669
Sealing Ring	1/8"	-	072652
Reducing Ferrule (hole ID smaller than the nominal size of fittings)	1/16"	0726283	0726701
	0.4 mm	-	0726703
	0.5 mm	-	0726702
	0.8 mm	0726270	072671
	1.2 mm	072628	-
	2.4 mm	-	0726700
Reducing Ferrule - Short	1.2 mm	072609	-
No-Hole Ferrule - Blank	No hole	-	072670
	2 x 0.8 mm	-	072674

Expert Tip :

Always re-tighten Graphite / Vespel® ferrules by ¼ to ½ turn after the first 2-3 oven cycles.



Ferrule Style	Hole ID	100% Graphite	15% Graphite / 85% Vespel®
¼" Fitting – All ferrules supplied in packets of 10			
 Straight (hole ID matches the nominal size of the fitting)	¼"	072621	072667
 Sealing Ring	¼"	0726003	072651
 Reducing Ferrule (hole ID smaller than the nominal size of fittings)	0.5 mm	-	0726660
	1/16"	0726282	072673
	1/8"	0726281	072668
	6.0 mm	0726212	0726673
 Reducing Ferrule - Short	1/8"	0726151	-
	5/16"	072617	-
	6.0 mm	072604	-
 No-Hole Ferrule - Blank	No hole	-	072666

Unions

SGE Unions are available in two material types: stainless steel and glass-lined stainless steel (GLT™ lined unions).

- Stainless steel unions come in a variety of tube sizes and configurations for example: straight through, reducing, tees, crosses and bulkheads.
- GLT™ unions are inert and mainly used for connecting fused silica tubing of various internal diameters.

All SGE unions are supplied with the appropriate nuts, ferrules and/or sealing rings.









Note: If unions are supplied with a "short" nut they can be converted into an "extended" nut. Replacement ferrules would then be standard ferrules, rather than the supplied short ferrules or sealing rings.



Stainless Steel Nut
Uses reducing ferrule - short or Graphite Ring



Extended Stainless Steel Nut

Union Types	1. Straight Through Unions.	4. Reducing Unions.	6. Union Tees.	8. Glass Lined Mini Unions.	9. SilTite™ Mini Unions.
	2. Bulkhead Unions.	5. Reducing Bulkhead Unions.	7. Union Cross.		
	3. Bulkhead Mini Unions.				
Images	<p>1. </p> <p>2. </p> <p>3. </p>	<p>4. </p> <p>5. </p>	<p>6. </p> <p>7. </p>	<p>8. </p>	<p>9. </p>

Union Types	1. Straight Through Unions. 2. Bulkhead Unions. 3. Bulkhead Mini Unions.	4. Reducing Unions. 5. Reducing Bulkhead Unions.	6. Union Tees. 7. Union Cross.	8. Glass Lined Mini Unions.	9. SilTite™ Mini Unions.
Material Characteristics	<ul style="list-style-type: none"> Available in Stainless steel or Glass lined (GLT™) Stainless steel. 	<ul style="list-style-type: none"> Stainless steel. 	<ul style="list-style-type: none"> Stainless steel. 	<ul style="list-style-type: none"> Glass Lined (GLT™) Stainless Steel. 	<ul style="list-style-type: none"> Glass Lined (GLT™) Stainless Steel. SilTite™ Mini Union utilize the SilTite™ technology – coupling SilTite™ ferrules with SilTite™ nuts.
Connections Suitable	<ul style="list-style-type: none"> Connecting tubing of the same diameter. Glass lined tubing (GLT™) and plastic tubing. 	<ul style="list-style-type: none"> For connecting tubing of different diameters. Suitable for glass lined tubing (GLT™), metal and plastic tubing. 	<ul style="list-style-type: none"> Union tees have the ability to have different size legs for different size tubing. 	<ul style="list-style-type: none"> Connecting fused silica and capillary tubing. Tubing of different sizes can also be connected. However, mini union ferrules for the tubing that is different than the normal usage need to be purchased separately. 	<ul style="list-style-type: none"> Recommended as the best option for attaching fused silica tubing in the laboratory. Please note that standard Mini Union nuts cannot be used with SilTite™ ferrules.
Features, Benefits and Applications	<ul style="list-style-type: none"> Low dead volume. Non-swaging, easy to remove fittings that will not deform tubing. High temperature operations - ferrules are the temperature limiting component. 	<ul style="list-style-type: none"> Non-swaging, easy to remove fittings that will not deform tubing. No back ferrule required. Gives greater flexibility with regards to micro-control valves. Suitable for glass lined (GLT™), metal and plastic tubing. 	<ul style="list-style-type: none"> Allows splitting of the flow between two or more outlets. Suitable for glass lined (GLT™), metal and plastic tubing. Non-swaging, easy to remove fittings that will not deform tubing. No back ferrule required. The male/female tees can be stacked in order to make a manifold of 1/16" tubing which can be used for drying samples or splitting sample stream to multiple outlets. 	<ul style="list-style-type: none"> Inert due to glass lining. Smaller in size than standard 1/16" unions, less of a heat sink and do not put extra weight on fused silica tubing connections. Fused silica connections due to the reduced weight and thermal mass. 	<ul style="list-style-type: none"> Allows for tubing to be connected without concern of leakage from temperature cycling or fear of getting pieces of the ferrule stuck inside the tubing.
Sizes available	<ul style="list-style-type: none"> 1/16" to 1/4". 	<ul style="list-style-type: none"> 1/16" to 1/8" to 1/4". 	<ul style="list-style-type: none"> SGE produces four different Tee configurations: <ol style="list-style-type: none"> all 1/16", 1 leg 1/8" and two legs 1/16", 1 leg 1/4" and two legs 1/16" and 1 leg 1/16" and two legs 1/8". The union cross is a four port union all set up to connect 1/16" tubing. 	<ul style="list-style-type: none"> 0.4 mm ID (for use with tubing <0.25 mm ID). 0.5 mm ID (for use with tubing 0.32 mm ID). 0.8 mm ID (for use with tubing 0.45 and 0.53 mm ID). 	<ul style="list-style-type: none"> 0.4 mm ID (for use with tubing < 0.25 mm ID). 0.5 mm ID (for use with tubing 0.32 mm ID). 0.8 mm ID (for use with tubing 0.45 and 0.53 mm ID). 1/32".

Straight Through Unions

Port 1 ID	Port 2 ID	Ferrule Type, ID and Part No.	Supplied with	Nut Type ID and Part No.	Use with Tubing ID Sizes	Use with Tubing OD Sizes	Part No.
Stainless Steel							
1/8"	1/8"	1/8" ID (072602)	5 ferrules and 2 nuts	1/8" ID (103402)	Any ID up to the OD of the tubing	1/8"	101310
1/16"	1/16"	1/16" (072603)	5 ferrules and 2 nuts	–	Any ID up to the OD of the tubing	1/16"	103330
1/16"	1/16"	Not supplied	2 nuts	SSN-16 (103403)	Any ID up to the OD of the tubing	1/16"	1033301
1/4"	1/4"	1/4" GFF (072601)	5 ferrules and 2 nuts	1/4" ID (103401)	Any ID up to the OD of the tubing	1/4"	101270
Glass Lined							
0.4 mm	0.4 mm	0.5 mm ID (072627)	5 ferrules and 2 nuts	103405	0.1 – 0.25 mm	0.32 to 0.36 mm	103419
0.5 mm	0.5 mm	0.5 mm ID (072627)	5 ferrules and 2 nuts	103405	0.32 mm	0.43 mm	103420
0.8 mm	0.8 mm	0.8 mm ID (072626)	5 ferrules and 2 nuts	103405	0.45 – 0.53 mm	0.68 mm	1034200

Bulkhead Unions

Description	Port 1 ID	Port 2 ID	Ferrule Type, ID & Part No.	Nut Type ID & Part No.	Supplied with	Use with Tubing ID Sizes	Use with Tubing OD Sizes	Part No.
VSLNU without Chamfer (Attaches Two Pieces of Fused Silica Tubing)								
SGE GC Union Bulkhead Stainless Steel w/ Locknut, for 1/8"	1/8"	1/8"	1/8" ID (072602)	1/8" ID (103402)	5 ferrules, 2 nuts	–	1/8" OD	101320
SGE GC Union Bulkhead Stainless Steel w/ Locknut, for 1/16"	1/16"	1/16"	1/16" ID (072603)	1/16" ID (103403)	5 ferrules, 2 nuts	–	1/16" OD	101340
SGE Bulkhead Union with glass lining of 0.4 mm ID	0.4 mm	0.4 mm	0.4 mm ID (072663)	(103405) or (103408)	2 ferrules, 2 nuts	From 0.1 – 0.25 mm ID to 0.1 – 0.25 mm ID	From 0.32 – 0.36 mm OD	1236302
SGE Bulkhead Union with glass lining of 0.5 mm ID	0.5 mm	0.5 mm	0.5 mm ID (072654)	(103405) or (103408)	2 ferrules, 2 nuts	0.32 mm ID	0.43 mm OD	1236300
SGE Bulkhead Union with glass lining of 0.8 mm ID	0.8 mm	0.8 mm	0.8 mm ID (072655)	(103405) or (103408)	2 ferrules, 2 nuts	From 0.1 – 0.25 mm ID to 0.45 – 0.53 mm ID	From 0.32 – 0.36 to 0.68 mm OD	1236306

Bulkhead Mini-Unions

Port 1 ID	Port 2 ID	Ferrule Type, ID & Part No.	Nut Type ID & Part No.	Supplied with	Use with Tubing ID Sizes	Use with Tubing OD Sizes	Part No.
0.5 mm	0.5 mm	0.5 mm ID (072630)	1.2 mm ID (103400)	5 ferrules, 2 nuts	0.32 mm ID	0.43 mm OD	103427
0.8 mm	0.8 mm	0.8 mm ID (072629)	1.2 mm ID (103400)	5 ferrules, 2 nuts	0.45 – 0.53 mm ID	0.68 mm OD	103428

Reducing Unions

Port 1 ID	Port 2 ID	Ferrule Type, ID & Part No.	Nut Type ID & Part No.	Use with Tubing OD Sizes	Part No.
1/4"	1/16"	1/16" ID (072603), 1/4" ID (072601)	1/4" ID (103401), 1/16" ID (103403)	1/16" and 1/4"	101230
1/4"	1/8"	1/8" ID (072602), 1/4" ID (072601)	1/4" ID (103401), 1/8" ID (103402)	1/8" and 1/4"	101250
1/8"	1/16"	1/16" ID (072603), 1/8" ID (072602)	1/16" ID (103403), 1/8" ID (103402)	1/16" and 1/8"	101290

Reducing Bulkhead Unions

Description	Port 1 ID	Port 2 ID	Ferrule Type, ID & Part No.	Nut Type ID & Part No.	Use with Tubing OD Sizes	Part No.
SGE GC Union Bulkhead Stainless Steel w/Locknut 1/8" to 1/16"	1/8"	1/16"	1/16" ID (072603) and 1/8" ID (072602)	1/8" ID (103402) and 1/16" ID (103403)	1/8" and 1/16" OD	101300

Union Tees

Port 1 ID	Port 2 ID	Port 3 ID	Ferrule Type, ID & Part No.	Nut Type ID & Part No.	Use with Tubing OD Sizes	Part No.
1/16"	1/16"	1/16"	1/16" ID (072603)	1/16" ID (103403)	1/16" OD	103418
1/8"	1/16"	1/16"	1/8" ID (072602), 1/16" ID (072603)	1/16" ID (103403), 1/8" ID (103402)	1/8" and 1/16" OD	1034180
1/8"	1/8"	1/16"	1/8" ID (072602), 1/16" ID (072603)	1/16" ID (103403), 1/8" ID (103402)	1/8" and 1/16" OD	1034181
1/4"	1/16"	1/16"	1/16" ID (072603), 1/4" ID (072601)	1/4" ID (103401), 1/16" ID (103403)	1/16" and 1/4" OD	1034183



GC Supplies





Union Cross

All Ports	Ferrule Type ID & Part No.	Nut Type, ID & Part No.	Ferrule Type, ID & Part No.	Nut Type, OD & Part No.	Part No.
1/16"	1/16" ID (072603)	1/16" ID (103403)	Any ID up to the OD of the tubing	1/16" OD	1034187



Glass Lined Mini Unions

Port 1 ID	Port 2 ID	Ferrule Type, ID & Part No.	Nut Type ID & Part No.	Column ID Size	Use with Tubing OD Sizes	Part No.
0.3 mm	0.3 mm	0.3 mm ID (072695)	1.2 mm ID (103400)	0.025 – 0.15 mm ID	0.22 – 0.285 mm OD	103430
0.4 mm	0.4 mm	0.4 mm ID (072696)	1.2 mm ID (103400)	0.1 – 0.25 mm ID	0.32 – 0.36 mm OD	103431
0.5 mm	0.5 mm	0.5 mm ID (072697)	1.2 mm ID (103400)	0.1mm, 0.25 mm and 0.36 mm	From 0.32 – 0.36 to 0.43 mm OD	103432
0.8 mm	0.8 mm	0.8 mm ID (072698)	1.2 mm ID (103400)	From 0.1 – 0.25 mm ID to 0.45 – 0.53 mm ID	From 0.32 – 0.36 to 0.68 mm OD	103433

The Mini Unions require the use of a 3/16" wrench for tightening since trying to set the ferrules properly with even a small adjustable wrench will lead to leaks or broken tubing. This wrench is available from SGE (Part Number 18500002).

GC Supplies



SilTite™ Mini Unions

For instrument specific SilTite™ connections, see the Instrument Quick Pick Guide from page 167.

Description	Port 1 ID	Port 2 ID	Ferrule Type, ID & Part No.	Nut Type ID & Part No.	Supplied with	Column ID Size	Use with Tubing OD Sizes	Part No.
SGE GC Ferrule SilTite™ (Metal) Mini Union, 0.25 mm ID Capillary Column.	0.4 mm	0.4 mm	0.4 mm ID (073470)	0.8 mm ID (073553)	5 ferrules, 2 nuts	0.1 – 0.25 mm ID	0.32 to 0.36 mm OD	073550
SGE GC Ferrule SilTite™ (Metal) Mini Union, 0.32 mm ID Capillary Column.	0.5 mm	0.5 mm	0.5 mm ID (073471)	0.8 mm ID (073553)	5 ferrules, 2 nuts	0.32 mm ID	0.43 mm OD	073551
SGE GC Ferrule SilTite™ (Metal) Mini Union, 0.53 mm ID Capillary Column.	0.8 mm	0.8 mm	0.8 mm ID (073472)	0.8 mm ID (073553)	5 ferrules, 2 nuts	0.45 – 0.53 mm ID	0.68 mm OD	073552
SGE GC Ferrule SilTite™ (Metal) Mini Union, 1/32" OD Metal Capillary Column.	1/32"	1/32"	1/32" ID (073219)	0.8 mm ID (073553)	5 ferrules, 2 nuts	Any ID up to the OD of the tubing	1/32" OD metal capillary columns	073554

All nuts used in SGE's fittings can be purchased as replacement parts.



Standard Stainless Steel



Extended Stainless Steel

Nuts for SGE Fittings

SGE has taken special consideration of the design of the connections and nuts for fittings. The nuts and fittings are unique in that the fitting is flat faced and the point of the ferrule is towards the nut. This makes a more robust system since the angled portion of the fitting cannot be damaged.

SGE nuts are made in a variety of:

- Materials - stainless steel, nickel plated brass and brass.

- Lengths - standard and extended.
- Tubing size - 1/16", 1/8" and 1/4" and mini-union.
- Hole sizes - regular or 1.2 mm for capillary columns.
- Configurations to compliment SGE's product range - regular, SilTite™ range and SilTite™ FingerTite range.

For instrument specific nuts please see the Instrument Quick Pick Guide from page 167.

Replacement Nuts

Description	Use with Tubing OD Sizes	Pack Size	Part No.
GC Nut Stainless Steel for SGE normal or short fittings	1/4"	5	103401
GC Nut Stainless Steel for SGE normal or short fittings	1/8"	5	103402
GC Nut Stainless Steel for SGE normal or short fittings	1/16"	5	103403
GC Nut Extended Stainless Steel for SGE long fittings	1/16"	5	103408
GC Nut Extended Stainless Steel for SGE long fittings	up to 1.2 mm	5	103405
GC Nut Extended BRASS for SGE long fittings	up to 1.2 mm	5	103406
Stainless Steel Male Nut	1/16"	5	1034030
Nut Mini-nut for mini-unions from SGE	up to 0.68 mm	5	103400

Replacement SilTite™ Nuts

Description	Use with Tubing OD Sizes	Pack Size	Part No.
SilTite™ Nut 10/32" and 1/16" ID	-	5	073225
SilTite™ Agilent Injector Nut	-	5	073226
SilTite™ Nut Thermo FIN	-	5	073230
SilTite™ Nut Varian	-	5	073231
SilTite™ Nut Shimadzu INJ	-	5	073232
SilTite™ Nut Shimadzu STD Interface	-	5	073233
GC Ferrule SilTite™ (Metal) Nut	up to 0.68 mm	5	073224
GC Ferrule SilTite™ (Metal) Mini-union Nuts for SilTite™ mini-unions only	up to 0.68 mm	5	073553

GC Supplies

GC Supplies | Gas Purifiers for GC

Gas purifiers are an essential part of your GC analysis. Without the appropriate gas purifier, problems such as noisy baselines, moisture entering GC column, excessive bleed, reduced column lifetime and irreproducible results will occur. These problems are created by hydrocarbons, moisture and oxygen in the carrier gases. It is recommended to use individual purifiers to handle each of these typical contaminants.

Which Purifier?

As a minimum requirement for capillary gas chromatography, especially for a new GC, SGE recommends the kit be connected as shown below, consisting of four gas purifiers to remove moisture, contaminating organic substances and oxygen.

The stainless steel bodies are approximately 300 mm long and 23 mm OD. They are designed for use at ambient temperature and at pressures below 100 psi.

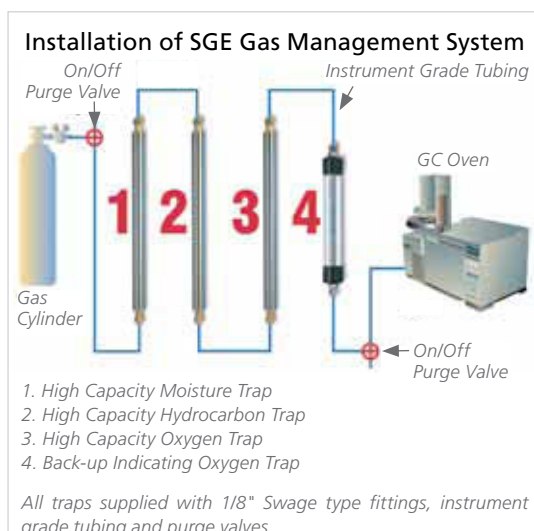

Advanced Gas Filter System

The AFS has high capacity and efficiency levels for oxygen (750 cc, < 1 ppb), water (12 g, < 10 ppb) and hydrocarbons (8 g, < 1 ppb). The recommended flow rate is 2 L/min and 200 psi maximum operating pressure. The two part system includes a small stainless steel manifold and a high capacity filter cartridge. Can be attached to a laboratory wall or bench with brackets included. Each connection in the AFS is made with two fluoro-elastomer seals. The polycarbonate shield that surrounds the glass indicator section of the filter is sealed, so the gas flow is secure even if the glass is broken.

Description	Fitting Size	Part No.
Advanced Gas Filter System	1/8"	1034884

Gas Purifier Kit

Description	Part No.
Essential Gas Purifier Kit Contains: Glass Moisture trap Hydrocarbon Trap Oxygen Trap Indicating Oxygen Trap	103494

Moisture Purifiers

These are gas filters for applications requiring high-efficiency moisture removal, with the benefit of a depletion indicator. Up to 6 grams water is removed to low-ppb levels. The adsorbing materials are Molecular Sieve 5A and cobalt-free CoFree™ indicator, held in a sturdy glass tube. The gas to be purified contacts only glass, metal and the adsorbents.

CoFree™ changes color from orange to green at about 5% relative humidity to signal leaks in the system; the molecular sieve removes moisture to trace levels. The glass tube is sealed with a special dual sealing system for extra protection from leaks. An internal frit at each end prevents particulate contamination. The inner glass tube is enclosed in a plastic outer tube for safety. Dimensions: 3.5 cm x 26 cm, maximum pressure 6.8 bar (100 psig)

Moisture Purifier for use with Packed GC Columns



Description	Fitting Size	Part No.
Glass Moisture Trap	1/8"	103495*

Hydrocarbon Trap

The trap capacity depends on the overall molecular weight of the contamination. Typically at 1 L/min, C4 hydrocarbons should be less than 15 ppb. The Hydrocarbon trap absorbs hydrocarbon contaminants in the carrier gas. Use with FID gas lines to improve baseline noise and sensitivity



Description	Fitting Size	Part No.
Hydrocarbon Trap	1/8"	103488*

Ideal for non-critical applications such as hydrogen combustion gas lined (not recommended for high resolution capillary chromatography).

Oxygen Scrubbers

- Huge 2.5 L capacity; reduces O₂ to low ppb levels.
- Advanced adsorbent technology.
- Outstanding efficiency in a small, high performance design.
- Recommended for GC/MS carrier gas.

Provides an extra large 2.5 L capacity for oxygen removal for long term purifications. May be used in any application requiring zero-grade oxygen-free gas.



Description	Fitting Size	Part No.
Oxygen Trap	1/8"	103486*

Indicating Oxygen Trap

The Indicating O₂ Trap is an improved, compact indicating filter for high-efficiency oxygen removal, suitable for use with chromatography carrier gas streams. It removes oxygen to low-ppb levels, with an indicator that changes color from green to gray when adsorption capacity is depleted. The adsorbent forms copper oxide in the presence of oxygen; no gas is generated. The Indicating Oxygen Trap is recommended as a downstream indicator for high-capacity oxygen traps. It can be used with non-oxidizing gases such as He, Ar, N₂, H₂ or CH₄. The adsorbents are held in a heavy-walled inner glass tube, shielded by an outer clear plastic tube for increased safety. Maximum pressure is 6.8 bar (100 psig). Approximate dimensions are 3.5 cm x 26 cm including fittings.



Description	Fitting Size	Part No.
Indicating Oxygen Trap	1/8"	103491*

* For 1/4" fittings contact your local SGE office.

Instrument Quick Pick for Agilent Technologies

Autosampler Syringes

All needles are 42 mm long with a cone point.

Agilent Technologies

Agilent 7673, 7683 & 6850 ALS

GC Supplies

Volume	Needle Gauge (OD mm)	Syringe Code	Syringe Part No.	Pack Size	Spare Needle Part No.	Pack Size	Spare Plunger Part No.	Pack Size
Fixed Tapered Needle								
5 µL	23-26s (0.63/0.47)	5F-AG-0.63/0.47C	001821	1	-	-	-	-
10 µL	23-26s (0.63/0.47)	10F-AG-0.63/0.47C	002821	1	-	-	-	-
10 µL Gas Tight	23-26s (0.63/0.47)	10F-AG-GT-0.63/0.47C	002826	1	-	-	031808	2
Fixed Straight Needle								
5 µL	26 (0.47)	5F-AG-0.47C	001800	1	-	-	-	-
5 µL(M)	23 (0.63)	5F-AG-0.63C	001810	1	-	-	-	-
10 µL	26 (0.47)	10F-AG-0.47C	002800	1	-	-	-	-
10 µL(M)	23 (0.63)	10F-AG-0.63C	002810	1	-	-	-	-
10 µL(M) Gas Tight	23 (0.63)	10F-AG-GT-0.63C	002812	1	-	-	031808	2
Removable Tapered Needle								
0.5 µL	23-26s (0.63/0.47)	0.5BR-AG-0.63/0.47C	000415	1	033730	1**	-	-
5 µL	23-26s (0.63/0.47)	5R-AG-0.63/0.47C	001825	1	036730	2	-	-
10 µL	23-26s (0.63/0.47)	10R-AG-0.63/0.47C	002825	1	037730	2	-	-
10 µL Gas Tight	23-26s (0.63/0.47)	10R-AG-GT-0.63/0.47C	002829	1	037730	2	031809	2
Removable Straight Needle								
0.5 µL	26 (0.47)	0.5BR-AG-0.47C	000400	1	033708	1**	-	-
0.5 µL (M)	23 (0.63)	0.5BR-AG-0.63C	000410	1	033715	1**	-	-
1 µL	23 (0.63)	1BR-AG-0.63C	000610	1	034715	1**	-	-
5 µL	26 (0.47)	5R-AG-0.47C	001805	1	036710	2	-	-
5 µL (M)	23 (0.63)	5R-AG-0.63C	001815	1	036720	2	-	-
10 µL	26 (0.47)	10R-AG-0.47C	002805	1	037715	2	-	-
10 µL (M)	23 (0.63)	10R-AG-0.63C	002815	1	037717	2	-	-
10 µL Gas Tight	26 (0.47)	10R-AG-GT-0.47C	002817	1	037715	2	031809	2
10 µL (M) Gas Tight	23 (0.63)	10R-AG-GT-0.63C	002818	1	037717	2	031809	2
Wide Bore Needle (For use with 10 µL syringe only)	23 (0.63/0.15 ID)	N10-AG-0.63(0.15)C	-		037725	2	-	-

(M) Suitable for use with the Merlin Microseal™ Injector. ** Denotes Spare Needle and Plunger kit.

Septa

Instrument	Diameter	Septum Type	Pack Size	Part No.
Agilent Technologies				
7890, 6890, 5890, 5880, 4890 & 6850	11	CS	50	041826
	11	TCS	50	041846
	11	TCS Pre-drilled	50	041856
	11	Auto-Sep™	25	041872
	11	Auto-Sep T™	25	041882
	11	Auto-Sep T™	100	041883
	11	HT	25	041898
	11	EC	25	041902

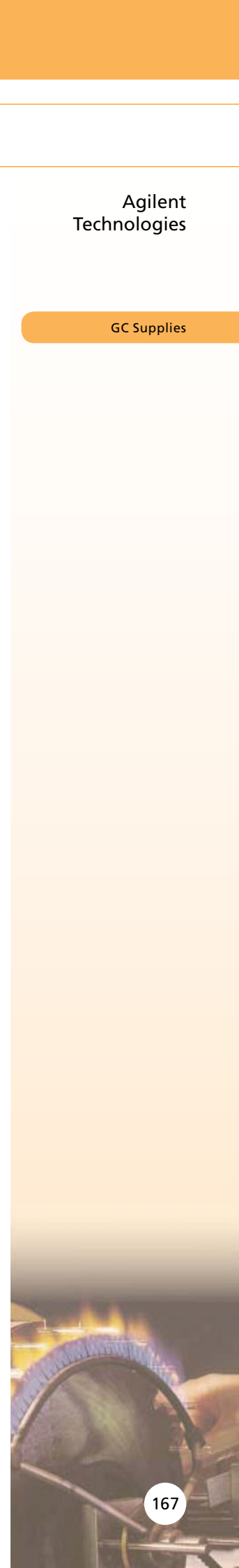









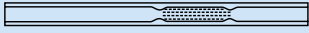

Septa Continued

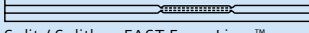
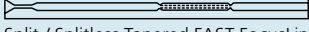
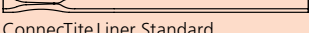
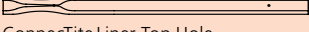
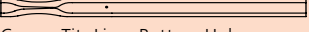
GC Supplies

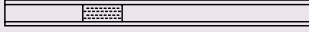

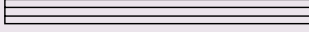

Instrument	Diameter	Septum Type	Pack Size	Part No.
5700, 5800 & 5900	9.5	CS	50	0418240
	9.5	TCS	50	0418440
	9.5	TCS Pre-drilled	50	0418540
	9.5	Auto-Sep™	25	041871
	9.5	Auto-Sep T™	25	041880
	9.5	HT	25	041897
	9.5	EC	25	041901
5750, 710, 720, 810 & 7610	12.5	CS	50	041828
	12.5	TCS	50	041848
	12.5	Auto-Sep T™	25	041884
	12.5	HT Pre-drilled	25	0418992
	12.5	EC	25	041906
7620, 5790, 5880 & 5890	5	CS	50	041820
	5	TCS Pre-drilled	50	041850
	5	HT Pre-drilled	25	0418991

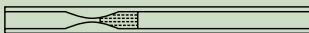
Inlet Liners

- Taper / Gooseneck
- FocusLiner™
- Taper Focus
- ConneCTite
- Straight
- Double Taper
- PTV/LVI

Description and Geometry Sketch	OD (mm)	ID (mm)	Length (mm)	Pack Size	Part No.
For Agilent 5890, 6850, 6890, 7890 and HP4890					
 Split / Splitless FocusLiner™	6.3	4	78.5	1	09200201
				5	092002
				25	092219
 Split / Splitless Tapered FocusLiner™	6.3	4	78.5	1	09200301
				5	092003
				25	092011
 Split / Splitless FAST FocusLiner™	6.3	2.3	78.5	1	09200501
				5	092005
				25	092008
 Split / Splitless Tapered FAST FocusLiner™	6.3	2.3	78.5	1	09211101
				5	092111
				25	092115
 ConneCTite Liner Standard	6.3	4	78.5	1	09232401
				5	092324
 ConneCTite Liner Top Hole	6.3	4	78.5	1	09232501
				5	092325
 ConneCTite Liner Bottom Hole	6.3	4	78.5	1	09232601
				5	092326
 Split, Straight-through Liner	6.3	4	78.5	1	09200701
				5	092007
				25	092222
 Split, with Quartz Wool	6.3	4	78.5	1	09200101
				5	092001
				25	092220
 Split / Splitless with Single Taper	6.3	4	78.5	1	09201701
				5	092017
				25	092229
 Split / Splitless with Single Taper (Quartz Wool)	6.3	4	78.5	1	09201901
				5	092019
				25	092218
 Split / Splitless with Double Taper	6.3	4	78.5	1	09201801
				5	092018
				25	092230
 Direct, Straight-through Liner	6.3	1.2	78.5	1	09201601
				5	092016
				25	092224
 Split / Splitless Quartz, Straight-through Liner	6.1	2	78.5	1	09200401
				5	092004
 Splitless with Recessed Gooseneck	6.3	2	78.5	1	09201301
				5	092013
 Split / Splitless Recessed Gooseneck (Quartz Wool)	6.3	4	78.5	1	09201001
				5	092010
				25	092223

Inlet Liners Continued

Packed Column Liner For Agilent 5880, 5890, 6890					
Description and Geometry Sketch	OD (mm)	ID (mm)	Length (mm)	Pack Size	Part No.
 1.8 mm ID Packed Column Liner	3	1.8	92	1	09223401
				5	092234
				25	092235
For AC Control Injector					
 Sim Dist Liner for Programmed Injector	3	1.6	73	1	09221001
				5	092210
				25	092211
For Gerstel CIS 4 Injector					
 Sintered Glass. Large Volume Injection (LVI)	3	1.8	71	1	09224301
				5	092243
 Single Baffle	3	1.8	71	1	09224601
				5	092246

O-rings

Description	Usage	Pack Size	Part No.
Viton O-Ring	Can be used at temperatures up to 300 °C. Suitable for liners with OD of 6.3 mm.	10	0726532
Graphite Sealing Ring	Can be used at temperatures up to 450 °C. Suitable for all inlet liners above except 092004 and 09200401.	10	0726005
Graphite Sealing Ring	Can be used at temperatures up to 450 °C. Suitable for use with liners 092004 and 09200401.	10	0726006

Ferrules

Instrument	Column ID	Ferrule ID	Pack Size	Part No.
15% Graphite / 85% Vespel® Ferrules				
For Injectors & Detectors at atmospheric pressure e.g. FID	0.1-0.25 mm	0.4 mm	10	073109
	0.32 mm	0.5 mm	10	073111
	0.53 mm	0.8 mm	10	073113
	for 1/8" OD Packed Columns	1/8"	10	072669
	for 1/4" OD Packed Columns	1/4"	10	072667
For GC-MS Interface Connection	0.1-0.25 mm	0.4 mm	10	072663
	0.32 mm	0.5 mm	10	072654
	0.53 mm	0.8 mm	10	072655
100% Graphite Ferrules				
Injectors & Detectors at atmospheric pressure e.g. FID (Not for GC-MS)	0.1-0.32 mm	0.5 mm	10	072635
	0.45-0.53 mm	0.8 mm	10	072636
	for 1/8" OD Packed Columns	1/8"	10	072602
	for 1/4" OD Packed Columns	1/4"	10	072601
SilTite™ Metal Ferrules				
For GC-MS Interface Connection (Starter Kit)	0.1-0.25 mm	0.4 mm	10*	073200
	0.32 mm	0.5 mm	10*	073201
	0.53 mm	0.8 mm	10*	073202
For Split / Splitless Injectors (Starter Kit)	0.1-0.25 mm	0.4 mm	10#	073270
	0.32 mm	0.5 mm	10#	073271
	0.45-0.53 mm	0.8 mm	10#	073272
	1/32"	0.81 mm	10#	073273
Replacement SilTite™ Metal Ferrules				
For All Connections	0.1-0.25 mm	0.4 mm	10	073220
	0.32 mm	0.5 mm	10	073221
	0.53 mm	0.8 mm	10	073222
	1/32"	0.81 mm	10	073219
Replacement SilTite™ Nuts				
For GC-MS Interface Connection	–	–	5	073224
For Split / Splitless Injector	–	–	5	073226
Replacement SilTite™ Base Seals				
For Split / Splitless Injector	–	–	2	073400
	–	–	10	073401

* Includes 10 ferrules, 2 SilTite™ nuts. # Includes 10 ferrules, 2 SilTite™ nuts and 2 SilTite™ Inlet Base Seals.

SilTite™ FingerTite Ferrules

Description	Pack Size	Part No.
Siltite™ FingerTite Agilent INJ / FID Starter Kit	*	073610
Siltite™ FingerTite Agilent Capillary / FID Starter Kit	*	073611
Siltite™ FingerTite Agilent INJ / MS Starter Kit	*	073612
Siltite™ FingerTite Ferrule 0.4 mm	Replacement Items 10	073630
Siltite™ FingerTite Ferrule 0.5 mm	Replacement Items 10	073631
Siltite™ FingerTite Blanking Ferrule	Replacement Items 2	073633
Siltite™ FingerTite Female Nut	Replacement Items 5	073636
Siltite™ FingerTite Agilent INJ Base Seal	Replacement Items 2	073640
Siltite™ FingerTite Starter Kit 0.4	#	0736100
Siltite™ FingerTite Agilent Capillary Adaptor	1	0736101
Siltite™ FingerTite Agilent MS Adaptor	1	0736102
Siltite™ FingerTite Agilent FID Detector	1	0736103
Siltite™ FingerTite Agilent Injector	1	0736104
Siltite™ FingerTite Starter Kit 0.5	#	0736105

* Each starter kit includes all the parts necessary to convert one GC system (one injector and one detector) to the SilTite™ FingerTite system suitable for installing 0.1 – 0.25 mm ID capillary columns. In addition there are 5 SilTite™ FingerTite nuts, one packet (10 ferrules) of 0.4 mm ID SilTite™ FingerTite ferrules and a ferrule install tool which allows you to seat the ferrule in the correct position on the capillary column.

0.4 and 0.5 Starter Kits include 10 ferrules for either 0.1 - 0.25 mm ID capillary columns (0.4) or 0.32 mm ID capillary columns (0.5) plus 5 SilTite™ FingerTite nuts and the ferrule install tool.

Electron Multipliers

Instrument	Analyzer Type	Technique	Part No.
Agilent Technologies			
5970 (All)	Quadrupole	GC-MS	14511
5971, 5972, GCD	Quadrupole	GC-MS	14516
5973 (For initial installation - includes mount)	Quadrupole	GC-MS	14617
5973 (Replacement multiplier only)	Quadrupole	GC-MS	14616

Instrument Quick Pick for PerkinElmer

Autosampler Syringes

All needles are 70 mm long with a cone point style.

PerkinElmer Autosystem











Volume	Needle Gauge (OD mm)	Syringe Code	Syringe Part No.	Pack Size	Spare Needle Part No.	Pack Size	Spare Plunger Part No.	Pack Size
Fixed Needle								
5 µL	26 (0.47)	5F-PE-0.47C	001953	1	–	–	–	–
5 µL	23 (0.63)	5F-PE-0.63C	001954	1	–	–	–	–
5 µL Gas Tight	26 (0.47)	5F-PE-GT-0.47C	001955	1	–	–	031807	2
5 µL Gas Tight	23 (0.63)	5F-PE-GT-0.63C	001957	1	–	–	031807	2
50 µL	23 (0.63)	50F-PE-0.63C	004670	1	–	–	–	–
Removable Needle								
0.5 µL	26 (0.47)	0.5BR-PE-0.47C	000475	1	033750	1**	–	–
0.5 µL	23 (0.63)	0.5BR-PE-0.63C	000478	1	033765	1**	–	–

**Denotes spare Needle and Plunger kit.

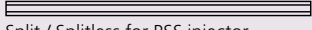
Septa

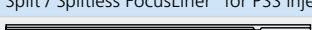
Instrument	Diameter	Septum Type	Pack Size	Part No.
PerkinElmer				
Sigma, 900, 990, 8000series, AutoSystem & Clarus	11	CS	50	041826
	11	TCS	50	041846
	11	TCS Pre-drilled	50	041856
	11	Auto-Sep™	25	041872
	11	Auto-Sep T™	25	041882
	11	Auto-Sep T™	100	041883
	11	HT	25	041898
	11	EC	25	041902

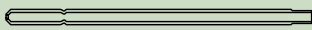
Inlet Liners

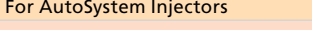
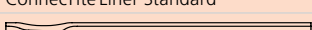
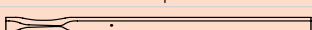
Description and Geometry Sketch	OD (mm)	ID (mm)	Length (mm)	Pack Size	Part No.
For AutoSystem™ & Clarus 500, 600					
 Split / Splitless Single Taper liner	6.2	4	92	1	09209901
				5	0920990
				25	092099025
 Split / Splitless FocusLiner™	6.2	4	92	1	09209201
				5	092092
				25	09209225
 Split / Splitless Tapered FocusLiner™	6.2	4	92	1	09209501
				5	092095
				25	09209525
 Split, straight-through liner	6.2	4	92	1	09210001
				5	092100
				25	09210025
 Splitless, straight-through liner	6.2	2	92	1	09210301
				5	092103
 Split / Splitless for PSS injector	4	2	86.2	1	09209801
				5	092098
 Split / Splitless FocusLiner™ for PSS injector	4	2	86.2	1	09210101
				5	092101
 Large Volume Injection (LVI) liner for PSS injector, sintered glass	4	2	86.2	1	09224401
				5	092244
 Packed Column liner	6	3	112	1	09223601
				5	092236
For 8000 and Sigma series					
 Split / Splitless	5	3	100	1	09209101
				5	092091
 Splitless with single taper	5	2	100	1	09209401
				5	092094
PTV Liner					
 PTV liner with 0.25 mm ID restriction (recessed gooseneck)	2	1	88	1	09209701
				5	092097
For AutoSystem Injectors					
 ConnecTite Liner Standard	6.2	4	92	1	09234401
				5	092344
 ConnecTite Liner Top Hole	6.2	4	92	1	09234501
				5	092345
 ConnecTite Liner Bottom Hole	6.2	4	92	1	09234601
				5	092346

GC Supplies

- Taper / Gooseneck
- FocusLiner™
- Taper Focus
- ConnecTite
- Straight
- Double Taper
- PTV/LVI

O-rings

Description	Usage	Pack Size	Part No.
Viton O-Ring	Can be used at temperatures up to 300 °C. For use with 6.2 mm OD liners.	10	0726536

Ferrules

Instrument	Column ID	Size of Nut	Ferrule ID	Pack Size	Part No.
15% Graphite / 85% Vespel® Ferrules					
For Injectors & Detectors at atmospheric pressure e.g. FID	0.1-0.25 mm	1/16"	0.4 mm	10	072663
	0.1-0.25 mm	1/8"	0.4 mm	10	0726703
	0.32 mm	1/16"	0.5 mm	10	072654
	0.32 mm	1/8"	0.5 mm	10	0726702
	0.45-0.53 mm	1/16"	0.8 mm	10	072655
	0.45-0.53 mm	1/8"	0.8 mm	10	072671
	1/8" OD Packed Columns	1/8"	1/8"	10	072669
	1/4" OD Packed Columns	1/4"	1/4"	10	072667

PerkinElmer

Ferrules Continued

100% Graphite Ferrules					
For Injectors & Detectors at atmospheric pressure e.g. FID (Not for GC-MS)	0.1-0.32 mm	1/16"	0.5 mm	10	072627
	0.1-0.32 mm	1/8"	0.5 mm	10	072624
	0.45-0.53 mm	1/16"	0.8 mm	10	072626
	0.45-0.53 mm	1/8"	0.8 mm	10	0726280
	1/8" OD Packed Columns	1/8"	1/8"	10	072622
	1/4" OD Packed Columns	1/4"	1/4"	10	072621
SilTite™ Metal Ferrules					
For GC-MS Interface Connection (Starter Kit)	0.1-0.25 mm	–	0.4 mm	10*	073200
	0.32 mm	–	0.5 mm	10*	073201
	0.53 mm	–	0.8 mm	10*	073202
Replacement SilTite™ Ferrules					
For GC-MS Interface Connection	0.1-0.25 mm	–	0.4 mm	10	073220
	0.32 mm	–	0.5 mm	10	073221
	0.53 mm	–	0.8 mm	10	073222
	1/32"	–	0.81 mm	10	073219
Replacement SilTite™ Nuts	–	–	5	–	073224

*Includes 10 ferrules, 2 SilTite™ nuts.

SilTite™ FingerTite Ferrules

Description	Column ID	Ferrule ID (mm)	Pack Size	Part No.
PerkinElmer				
Injector/GC-MS	0.1-0.25 mm	0.4	*	073623
Injector/FID	0.1-0.25 mm	0.4	*	073622
Ferrule 0.4 mm	Replacement Items	0.1-0.25 mm	10	073630
Ferrule 0.5 mm	Replacement Items	0.32 mm	10	073631
Ferrule Blanking	Replacement Items	–	2	073633
Female Nut	Replacement Items	–	5	073636

* Each starter kit includes all the parts necessary to convert one GC system (one injector and one detector) to the SilTite™ FingerTite system suitable for installing 0.1 – 0.25 mm ID capillary columns. In addition there are 5 SilTite™ FingerTite nuts, one packet (10 ferrules) of 0.4 mm ID SilTite™ FingerTite ferrules and a ferrule install tool which allows you to seat the ferrule in the correct position on the capillary column.

Instrument Quick Pick for Shimadzu

Shimadzu

Autosampler Syringes

All needles are 42 mm long with a cone point style.

Shimadzu AOC14, AOC17 and AOC20













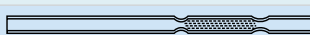

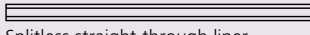



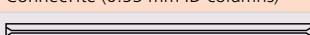

Volume	Needle Gauge (OD mm)	Syringe Code	Syringe Part No.	Pack Size	Spare Needle Part No.	Pack Size	Spare Plunger Part No.	Pack Size
Fixed Needle								
5 µL	26 (0.47)	5F-S-0.47C	001987	1	–	–	–	–
5 µL	23 (0.63)	5F-S-0.63C	001988	1	–	–	–	–
250 µL Gas Tight	23 (0.63)	250F-S-GT-0.63C	006682	1	–	–	031828	1
Removable Needle								
0.5 µL	26 (0.47)	0.5BR-S-0.47C	000440	1	033738	1**	–	–
0.5 µL	23 (0.63)	0.5BR-S-0.63C	000445	1	033745	1**	–	–
0.5 µL	23-26s (0.63/0.47)	0.5BNR-S-0.63/0.47C	000450	1	033730	1**	–	–
10 µL	26 (0.47)	10R-S-0.47C	002897	1	037745	2	–	–
10 µL	23 (0.63)	10R-S-0.63C	002898	1	037747	2	–	–
10 µL Gas Tight	23 (0.63)	10R-S-GT-0.63C	002902	1	037747	2	031798	2

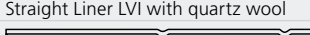
**Denotes spare Needle and Plunger kit.

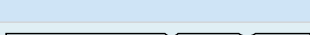
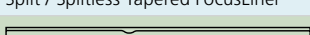
Septa

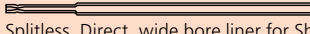
Instrument	Septum Type	Pack Size	Part No.
9A, 14, 15A, 16, 17A, 2010 & 2014	Enduro Blue	50	041890
	HT	50	041895
	EC	50	041905

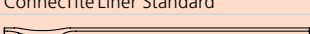
Inlet Liners

Description and Geometry Sketch	OD (mm)	ID (mm)	Length (mm)	Pack Size	Part No.
For GC-2010 (SPL-2010 Injector), GC-2014 (SPL-2014 Injector) and GC-17A (SPL-17 Injector)					
 Split / Splitless FocusLiner™ *	5	3.4	95	1	09205901
				5	092059
				25	09205925
 Split / Splitless Tapered FocusLiner™ *	5	3.4	95	1	09205801
				5	092058
				25	09205825
 Split / Splitless FocusLiner™	5	3.4	95	1	09206201
				5	092062
 Split / Splitless Tapered FocusLiner™	5	3.4	95	1	09206801
				5	092068
				25	09206825
 Split, straight-through liner	5	3.4	95	1	09206401
				5	092064
 Splitless straight-through liner	5	2.6	95	1	092086101
				5	0920861
 Split / Splitless with Single Taper	5	3.4	95	1	09207101
				5	092071
 Split / Splitless with middle gooseneck	5	3.4	95	1	09207701
				5	092077
				25	09207725
 Split / Splitless with recessed gooseneck and quartz wool	5	3.4	95	1	09206101
				5	092061
 Split / Splitless with middle gooseneck	5	3.4	95	1	09208501
				5	092085
 ConnectTite (0.53 mm ID columns)	5	2.6	95	1	09208701
				5	092087
 SPME Liner	5	0.75	95	1	09208901
				5	092089
For GC-2010 (PTV Injector)					
 Straight Liner LVI with quartz wool	3.1	1.5	95	5	092292
 PTV Liner with 3 baffles	3.1	1.5	95	5	0920425
For GC-14 (SPL-14 Injector)					
 Split / Splitless FocusLiner™	5	3.4	99	1	09206501
				5	092065
				25	09206225
 Split / Splitless Tapered FocusLiner™	5	3.4	99	1	09206601
				5	092066
 Split / Splitless with 2.0 mm middle gooseneck	5	3.4	99	1	09208201
				5	092082
 Split / Splitless with single taper	5	3.4	99	1	092083101
				5	0920831
 Splitless, Direct, wide bore liner for Shimadzu 9A/16A GC	5	3.4	139	1	09208401
				5	092084
 ConnectTite Liner Standard	5	3.4	95	1	09232901
				5	092329
 ConnectTite Liner Top Hole	5	3.4	95	1	09233001
				5	092330
 ConnectTite Liner Bottom Hole	5	3.4	95	1	09233101
				5	092331

* When using a standard 42 mm needle for autosamplers, the sample will be injected on top of the wool for this liner.

O-rings and Sealing Rings

Description	Usage	Pack Size	Part No.
Graphite Sealing Ring	Can be used at temperatures up to 450 °C. For 14, 15A & 16 (SPL-14 injector).	10	0726001
Graphite Sealing Ring	Can be used at temperatures up to 450 °C. For 17A (SPL-17 injector).	10	0726007
Viton O-Ring	Can be used at temperatures up to 300 °C. For 2010 & 2014 (SPL-2010 Injector & SPL-2014 Injector).	10	0726533

GC Supplies

- Taper / Gooseneck
- FocusLiner™
- Taper Focus
- ConnectTite
- Straight
- Double Taper
- PTV/LVI

Ferrules

Column ID	Description	Pack Size	Part No.
GC14A, GC17A, GC2010 and GC2014 Detector / Injectors (Not for MS interfaces or QP2010 Injector)			
0.10-0.32 mm ID columns	100% Graphite	10	0726080
0.45-0.53 mm ID columns	100% Graphite	10	0726082
5 mm OD packed columns	100% Graphite	10	0726001
0.10-0.25 mm ID columns	SilTite™ Metal - Initial Installation	10*	073350
0.10-0.25 mm ID columns	SilTite™ Ferrules	10	073227
0.32 mm ID columns	SilTite™ Metal - Initial Installation	10*	073351
0.32 mm ID columns	SilTite™ Ferrules	10	073228
0.45-0.53 mm ID columns	SilTite™ Metal - Initial Installation	10*	073352
0.53 mm ID columns	SilTite™ Ferrules	10	073229
n/a	SilTite™ Metal Nuts - Slotted	5	073232
QP5000/5050 Standard MS Interface			
QP5000-I 0.10-0.25 mm ID columns	15% Graphite/ 85% Vespel® Ferrules	10	0726563
QP5000-I 0.32 mm ID columns	15% Graphite/ 85% Vespel® Ferrules	10	0726564
QP5000-II & QP5050 0.10-0.25 mm ID columns	15% Graphite/ 85% Vespel® Ferrules	10	0726561
QP5000-II & QP5050 0.32 mm ID columns	15% Graphite/ 85% Vespel® Ferrules	10	0726562
0.10-0.25 mm ID columns	SilTite™ Metal - Initial Installation	10*	073204
0.10-0.25 mm ID columns	SilTite™ Ferrules	10	073227
0.32 mm ID columns	SilTite™ Metal - Initial Installation	10*	073205
0.32 mm ID columns	SilTite™ Ferrules	10	073228
0.53 mm ID columns	SilTite™ Metal - Initial Installation	10*	073206
0.53 mm ID columns	SilTite™ Ferrules	10	073229
n/a	SilTite™ Metal Nuts-QP5000/5050 Standard MS interface	5	073233
QP5000/5050 Wide Bore MS Interface, QP2010 Injector and QP2010 Standard MS Interface			
0.10-0.25 mm ID columns	15% Graphite/ 85% Vespel® Ferrules	10	072663
0.32 mm ID columns	15% Graphite/ 85% Vespel® Ferrules	10	072654
0.45-0.53 mm ID columns	15% Graphite/ 85% Vespel® Ferrules	10	072655
0.10-0.25 mm ID columns	SilTite™ Metal - Initial Installation	10*	073200
0.10-0.25 mm ID columns	SilTite™ Ferrules	10	073220
0.32 mm ID columns	SilTite™ Metal - Initial Installation	10*	073201
0.32 mm ID columns	SilTite™ Ferrules	10	073221
0.45-0.53 mm ID columns	SilTite™ Metal - Initial Installation	10*	073202
0.45-0.53 mm ID columns	SilTite™ Ferrules	10	073222
n/a	SilTite™ Metal Nuts	5	073224

* Includes 10 ferrules, 2 SilTite™ nuts.

Replacement Parts

Material	Pack Size	Part No.
Replacement SilTite™ Nuts		
For 2010 GC-MS System	5	073224
For 2010 GC-MS System with QP5000 series MS	5	073224
For 2010/2014 GC Injectors and atmospheric detectors	5	073224
QP5000 Jet Separator MS Interface	5	073224
QP5000 Direct MS Interface	5	073233
For All Injectors Jet Separator (Starter Kit), except 2010/2014	5	073232

SilTite™ FingerTite Ferrules

Description	Pack Size	Part No.
SilTite™ Fingertite Shimadzu 2010 Inj / Fid Starter Kit	*	073620
SilTite™ Fingertite Shimadzu 2010 Inj / Ms Starter Kit	*	073621
SilTite™ Fingertite Ferrule 0.4 mm	Replacement Items 10	073630
SilTite™ Fingertite Ferrule 0.5 mm	Replacement Items 10	073631
SilTite™ Fingertite Blanking Ferrule	Replacement Items 2	073633
SilTite™ Fingertite Female Nut	Replacement Items 5	073636

* Each starter kit includes all the parts necessary to convert one GC system (one injector and one detector) to the SilTite™ FingerTite system suitable for installing 0.1 – 0.25 mm ID capillary columns. In addition there are 5 SilTite™ FingerTite nuts, one packet (10 ferrules) of 0.4 mm ID SilTite™ FingerTite ferrules and a ferrule install tool which allows you to seat the ferrule in the correct position on the capillary column.

Electron Multipliers

MS Description	Analyzer Type	Technique	Part No.
QP5000	Quadrupole	GC-MS	14533

Instrument Quick Pick for Thermo Scientific

Thermo Scientific

Autosampler Syringes for Thermo Scientific / CE Instruments / Fisons

All needles have a cone point style.











GC Supplies

AUTOSAMPLER				NEEDLE SPECIFICATIONS						
TriPlus	AS3000	AS2000	AS200/800	Volume	Length (mm)	Gauge	Syringe Code	Syringe Part No.	Needle Part No.	Pack Size
Fixed Needle										
•				5 µL	50	26 (0.47)	5FX-5C	001105	–	–
•		•		10 µL	50	23 (0.63)	10F-C/T-GT-5/0.63C	002987	–	–
•		•		10 µL	80	23 (0.63)	10F-C/T-8/0.63C	002989	–	–
•		•		10 µL	80	26 (0.47)	10F-C/T-8/0.47C	002992	–	–
•	•	•	•	10 µL	50	25 (0.50)	10F-C/T-5/0.50C	002967	–	–
•	•	•	•	10 µL	50	23 (0.63)	10F-C/T-5/0.63C	002981	–	–
•	•	•	•	10 µL	50	26 (0.47)	10F-C/T-5/0.47C	002980	–	–
Removable Needle										
•	•	•		10 µL	50	26 (0.47)	10R-C/T-5/0.47C	002982	037785	2
•	•	•	•	10 µL	50	23 (0.63)	10R-C/T-5/0.63C	002984	037787	2
•		•	•	10 µL	80	26 (0.47)	10R-C/T-8/0.47C	002993	031535	3
•	•			0.5 µL	50	26 (0.47)	0.5BNR-C/T-5/0.47C	000490	033770	–
•	•			0.5 µL	50	23 (0.63)	0.5BNR-C/T-5/0.63C	000492	033772	–

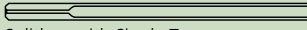
Septa

Instrument	Diameter (mm)	Septum Type	Pack Size	Part No.
8000 Series, FOCUS, Trace/ULTRA GC™	17	TCS	50	0418491
	17	Auto-Sep T™	25	041886
	17	HT	25	0418990
	17	EC	25	041903

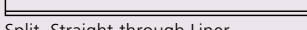

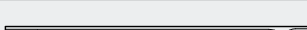
Inlet Liners

Description and Geometry Sketch	OD (mm)	ID (mm)	Length (mm)	Pack Size	Part no.
For TRACE™ and Focus™					
 Splitless FocusLiner™ (for use with 70 mm Needle)	8	5	105	1	09204501
				5	092045
 Splitless FocusLiner™ with Top-end Restriction (for use with 70 mm Needle)	8	5	105	1	09204601
				5	092046
				25	09204625
 Split FocusLiner™ (for use with 50 mm Needle)	8	5	105	1	09204801
				5	092048
 Splitless FocusLiner™ (for use with 50 mm Needle)	8	5	105	1	09204901
				5	092049
 Splitless with Single Taper	8	3	105	1	09214101
				5	092141
				25	09214125
 Splitless with Single Taper	8	5	105	1	09214401
				5	092144
				25	09214425
 Splitless, Straight-through Liner	8	3	105	1	09214701
				5	092147
				25	09214725
 SPME Liner	8	0.8	105	1	09214801
				5	092148
 Split, Straight-through Liner	8	5	105	1	0921501
				5	092150
				25	09215025
 Trace 2000 PTV Liner	2.75	1.75	120	1	09214201
				5	092142
				25	
 Sintered Glass, Large Volume Injection (LVI) Liner	2.75	0.78/1.8	120	1	09215501
				5	092155
				25	09215525

For inlet liners to suit Finnigan 9001 and GCQ GCs, see the Agilent Liners page 168.

- Taper / Gooseneck
- FocusLiner™
- Taper Focus
- ConneCTite
- Straight
- Double Taper
- PTV/LVI

Inlet liners Continued

Description and Geometry Sketch	OD (mm)	ID (mm)	Length (mm)	Pack Size	Part no.
 ConnecTite Liner Standard	8	5	105	1	09233401
				5	092334
 ConnecTite Liner Top Hole	8	5	105	1	09233501
				5	092335
 ConnecTite Liner Bottom Hole	8	5	105	1	09233601
				5	092336

Sealing Rings

Description	Usage	Pack Size	Part No.
Graphite Sealing Ring	8 mm ID. For 8000 & TRACE GCs.	10	0726004

Ferrules

Instrument	Column ID	Ferrule ID	Pack Size	Part No.
15% Graphite / 85% Vespel® Ferrules				
For All Injectors & Detectors (Not for 8000 Series, Focus, Trace/Ultra GC)	0.1-0.25 mm	0.4 mm	10	0726549
	0.32 mm	0.5 mm	10	0726557
	0.53 mm	0.8 mm	10	0726548
	1/8" OD Packed Columns	1/8"	10	072669
	1/4" OD Packed Columns	1/4"	10	072667
For All Focus, Trace/Ultra Injectors & Detectors at atmospheric pressure e.g. FID (Not for GC-MS)	0.1-0.25 mm	0.4 mm	10#	072696
	0.32 mm	0.5 mm	10#	072697
	0.53 mm	0.8 mm	10#	072698
Brass Nut for Focus, Trace/Ultra GC Injectors & Non-MS Detectors			2	1034085
100% Graphite Ferrules				
For Injectors & Detectors at atmospheric pressure e.g. FID (Not for GC-MS)	0.1-0.32 mm	0.5 mm	10	072619
	0.45-0.53 mm	0.8 mm	10	072614
	1/8" OD Packed Columns	1/8"	10	072622
	1/4" OD Packed Columns	1/4"	10	072621
SilTite™ Metal Ferrules				
For GC-MS Interface Connections (Starter Kit)	0.1-0.25 mm	0.4 mm	10*	073450
	0.32 mm	0.5 mm	10*	073451
	0.53 mm	0.8 mm	10*	073452
	1/32"	0.81 mm	10*	073453
Replacement SilTite™ Metal Ferrules				
For All GC-MS Interface Connections	0.1-0.25 mm	0.4 mm	10	073330
	0.32 mm	0.5 mm	10	073331
	0.53 mm	0.8 mm	10	073332
	1/32"	0.81 mm	10	073333
Replacement SilTite™ Nuts				
			5	073230

To be used in combination with brass nut (Part No. 1034085) * Includes 10 ferrules, 2 SilTite™ nuts.

SilTite™ FingerTite Ferrules

Description	Column ID	Ferrule ID (mm)	Pack Size	Part No.
Thermo (Available from SGE on 1/1/2011)				
Injector/GC-MS (non-ISQ)	0.1-0.25 mm	0.4	*	073616
Injector/GC-MS ISQ	0.1-0.25 mm	0.4	*	073615
Injector/FID	0.1-0.25 mm	0.4	*	073614
Ferrule 0.4 mm	0.1-0.25 mm	0.4	10	073630
Ferrule 0.5 mm	0.32 mm	0.5	10	073631
Ferrule Blanking	–	–	2	073633
Female Nut	–	–	5	073636

* Each starter kit includes all the parts necessary to convert one GC system (one injector and one detector) to the SilTite™ FingerTite system suitable for installing 0.1 – 0.25 mm ID capillary columns. In addition there are 5 SilTite™ FingerTite nuts, one packet (10 ferrules) of 0.4 mm ID SilTite™ FingerTite ferrules and a ferrule install tool which allows you to seat the ferrule in the correct position on the capillary column.

Instrument Quick Pick for Varian / Bruker

Autosampler Syringes

Volume	Length	Needle Gauge (OD mm)	Tip Style	Syringe Code	Syringe Part No.	Pack Size	Needle Part No.	Pack Size	Plunger Part No.	Pack Size
Varian/Bruker 8035, 8100 and 8200										
Fixed Needle										
10 µL Gas Tight	53	25 (0.5)	S/Hole	10F-GT-VA8X-II	002923	1	-	-	031218	1
Removable Needle										
1 µL*	51	26 (0.47)	Cone	1BR-VA8X	000655	1	034720	1**	-	-
10 µL Gas Tight	53	25 (0.5)	S/Hole	10R-GT-VA8X-II	002924	1	037777	1	031218	1
Needle Alternatives for P/N 002924										
	50	25 (0.5)	Bevel	N10-VA8035-II	-	1	037776	2	-	-
	105	-	OC	N10-VA8035-0.17-II	-	1	037778	2	-	-
	53	23 (0.63)	S/Hole	N10-VA8X00H-0.63-II	-	1	037779	2	-	-
	53	25 (0.5)	S/Hole	N10-VA800H-II(0.2)	-	1	037780	1	-	-
100 µL Gas Tight	53	25 (0.5)	S/Hole	100R-GT-VA8X	005921	1	038745	1	031824	1
Varian/Bruker CP-8400/8410, CP-9010/9050										
Fixed Needle										
10 µL	50	26 (0.47)	Bevel	10F-VA8400-5/0.47	002950	1	-	-	-	-
10 µL	50	23 (0.63)	Cone	10F-C/T-5/0.63C	002981	1	-	-	-	-
Removable Needle										
10 µL	50	26 (0.47)	Cone	10R-C/T-5/0.47C	002982	1	037785	2	-	-

*Not suitable for 8200 autosampler. **Denotes Plunger and Needle Kit.

Septa

Instrument	Diameter	Septum Type	Pack Size	Part No.
Varian/Bruker				
1177 Injector	9	CS	50	041824
	9	TCS	50	041844
	9	TCS Pre-drilled	50	041854
	9	Auto-Sep T™	25	041879
	9	HT	25	041896
	9	EC	25	041900
1040, 1041, 1060 & 1061 Injectors	9.5	CS	50	0418240
	9.5	TCS	50	0418440
	9.5	TCS Pre-drilled	50	0418540
	9.5	Auto-Sep™	25	041871
	9.5	Auto-Sep T™	25	041880
	9.5	HT	25	041897
	9.5	EC	25	041901
1075, 1077, 1078, 1079 & 1093, 1094 SPI Injectors	11	CS	50	041826
	11	TCS	50	041846
	11	TCS Pre-drilled	50	041856
	11	Auto-Sep™	25	041872
	11	Auto-Sep T™	25	041882
	11	Auto-Sep T™	100	041883
	11	HT	25	041898
	11	EC	25	041902

GC Supplies











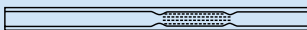

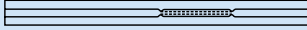
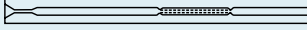

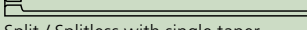
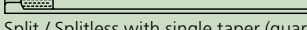
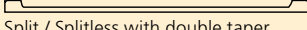
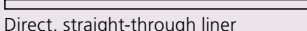
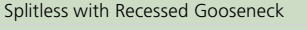
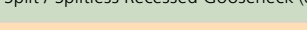

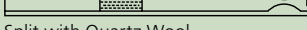
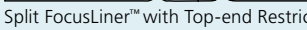

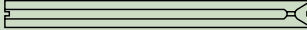
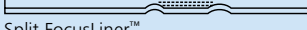
Varian / Bruker

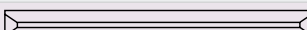
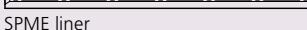
Inlet Liners

GC Supplies

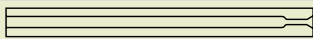
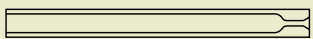
- Taper / Gooseneck
- FocusLiner™
- Taper Focus
- ConneCTite
- Straight
- Double Taper
- PTV/LVI

Description and Geometry Sketch	OD (mm)	ID (mm)	Length (mm)	Pack Size	Part no.
For 1177 Injector					
 Split / Splitless FocusLiner™	6.3	4	78.5	1	09200201
				5	092002
				25	092219
 Split / Splitless Tapered FocusLiner™	6.3	4	78.5	1	09221901
				5	092003
				25	092011
 Split / Splitless FAST FocusLiner™	6.3	2.3	78.5	1	09200501
				5	092005
				25	092008
 Split / Splitless Tapered FAST FocusLiner™	6.3	2.3	78.5	1	09211101
				5	092111
				25	092115
 Split, straight-through liner	6.3	4	78.5	1	09200701
				5	092007
				25	092222
 Split, with quartz wool	6.3	4	78.5	1	09200101
				5	092001
				25	092220
 Split / Splitless with single taper	6.3	4	78.5	1	09201701
				5	092017
				25	092229
 Split / Splitless with single taper (quartz wool)	6.3	4	78.5	1	09201901
				5	092019
				25	092218
 Split / Splitless with double taper	6.3	4	78.5	1	09201801
				5	092018
				25	092230
 Direct, straight-through liner	6.3	1.2	78.5	1	09201601
				5	092016
				25	092224
 Splitless with Recessed Gooseneck	6.3	2	78.5	1	09201301
				5	092013
 Split / Splitless Recessed Gooseneck (quartz wool)	6.3	4	78.5	1	09201001
				5	092010
				25	092223
For 1075/1077 Injector					
 Split, FAST FocusLiner™	6.3	2.3	72	1	09211301
				5	092113
 Split with Quartz Wool	6.3	4	72	1	09202101
				5	092021
				25	0922125
 Split FocusLiner™ with Top-end Restriction	6.3	4	72	1	09202801
				5	092028
 Splitless FocusLiner™ with Top-end Restriction	6.3	4	74	1	09202601
				5	092026
 Split, Tapered FocusLiner™	6.3	4	72	1	09202501
				5	092025
 Splitless, Slots at Both Ends	6.3	2	74	1	09202401
				5	092024
				25	092228
 Split FocusLiner™	6.3	4	72	1	09202201
				5	092022
For 1078/1079 Injector					
 Sintered Glass, Large Volume Injection (LVI) Liner	5	1.8/3.4	54	1	09224501
				5	092245
				25	09224525
 Straight-through Liner	5	0.5	54	1	09203101
				5	092031
 SPME liner	5	0.75	54	1	09211701
				5	092117

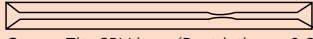
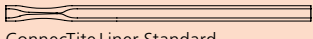
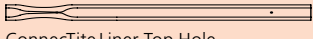
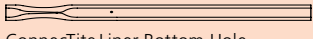
 Splitless with Single Taper	5	2	54	1	09203901
				5	092039
 Split / Splitless with single taper	5	3.4	54	1	09203801
				5	092038
				25	09203825
 Split / Splitless FocusLiner™	5	3.4	54	1	09203701
				5	092037
				25	09203725
 Split / Splitless Tapered FocusLiner™	5	3.4	54	1	09203601
				5	092036
				25	09203625
For 1093/1094 Injector					
 ConnectTite SPI Liner, (Restriction = 0.25 mm)	4.6	0.5	54	1	09202701
				5	092027
 ConnectTite SPI Liner, (Restriction = 0.5 mm) for 0.53 mm ID On-column	4.6	0.8	54	1	09203401
				5	092034
				25	09203425
 ConnectTite SPI Liner, (Restriction = 0.25 mm)	4.6	0.8	54	1	09203001
				5	092030
For 1075/1079 Injector					
 ConnectTite Liner Standard	6.3	4	72	1	09233901
				5	092339
 ConnectTite Liner Top Hole	6.3	4	72	1	09234001
				5	092340
 ConnectTite Liner Bottom Hole	6.3	4	72	1	09234101
				5	092341

O-rings and Sealing Rings

Description	Usage	Pack Size	Part No.
Viton O-Ring for 1177 Injector	Can be used at temperatures up to 300 °C.	10	0726532
Graphite Sealing Ring for 1075 & 1077 Injectors		10	072601
Graphite Sealing Ring for 1078 & 1079 Injectors		10	0726217

Ferrules

Instrument	Column ID	Ferrule ID	Pack Size	Part No.
15% Graphite / 85% Vespel® Ferrules				
For GC-MS & Detectors at atmospheric pressure e.g. FID	0.1-0.25 mm	0.4 mm	10	072663
	0.32 mm	0.5 mm	10	072654
	0.53 mm	0.8 mm	10	072655
Packed Columns	1/8" OD Packed Columns	1/8"	10	072669
	1/4" OD Packed Columns	1/4"	10	072667
100% Graphite Ferrules				
For Injectors & Detectors at atmospheric pressure e.g. FID	0.1-0.32 mm	0.5 mm	10	072627
	0.45-0.53 mm	0.8 mm	10	072626
	1/8" OD Packed Columns	1/8"	10	072622
	1/4" OD Packed Columns	1/4"	10	072621
SilTite™ Metal Ferrules				
For GC-MS Interface Connections (Starter Kit)	0.1-0.25 mm	0.4 mm	10*	073300
	0.32 mm	0.5 mm	10*	073301
	0.53 mm	0.8 mm	10*	073302
	1/32"	0.81 mm	10*	073303
Nuts for Varian Injector			2	1034060

* Includes 10 ferrules, 2 SilTite™ nuts.

Varian / Bruker

Ferrules Continued

Instrument	Column ID	Ferrule ID	Pack Size	Part No.
Replacement SilTite™ Ferrules				
For GC-MS Interface Connections	0.1-0.25 mm	0.4 mm	10	073220
	0.32 mm	0.5 mm	10	073221
	0.53 mm	0.8 mm	10	073222
	1/32"	0.81 mm	10	073219
Replacement SilTite™ Nuts				
			5	073231

*Includes 10 ferrules, 2 SilTite™ nuts.

GC Supplies

SilTite™ FingerTite Ferrules

Description	Column ID	Ferrule ID (mm)	Pack Size	Part No.
Varian/Bruker				
Injector/GC-MS	0.1-0.25 mm	0.4	*	073619
Injector/FID	0.1-0.25 mm	0.4	*	073618
Ferrule 0.4 mm	0.1-0.25 mm	0.4	10	073630
Ferrule 0.5 mm	0.32 mm	0.5	10	073631
Ferrule Blanking	-	-	2	073633
Female Nut	-	-	5	073636

* Each starter kit includes all the parts necessary to convert one GC system (one injector and one detector) to the SilTite™ FingerTite system suitable for installing 0.1 – 0.25 mm ID capillary columns. In addition there are 5 SilTite™ FingerTite nuts, one packet (10 ferrules) of 0.4 mm ID SilTite™ FingerTite ferrules and a ferrule install tool which allows you to seat the ferrule in the correct position on the capillary column.



Electron Multipliers

MS Description	Analyzer Type	Technique	Part No.
Saturn 2000, 2100 & 2200	Ion trap	GC-MS	14147

Instrument Quick Pick for ATAS Optic Injectors

ATAS

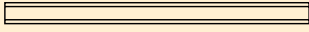
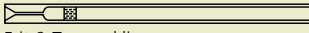
Inlet Liners

Description and Geometry Sketch	OD (mm)	ID (mm)	Length (mm)	Pack Size	Part No.
 Straight-through Liner	5	3	81	1	0922701
				5	092270
 Frit & Tapered liner	5	3	81	1	09227301
				5	092273
 Split / Splitless FocusLiner™	5	3	81	1	09227201
				5	092272



GC Accessories

SilFlow™	182-184
Splitters	184-187
Micro-control Valves	188-191
Cold Traps	192
Cryogenic Cold Trap	192
Capillary Washing/Coating Reservoir	193
Flame Ionization Detector (FID)	194
Capillary Cutting Tools	195
Retention Gap Kits	195
Gas & Vapor Field Sampler	195
Soap Bubble Flow Meters	195

Innovative Solutions to Enhance Your Chromatography

In SGE's 50 years as a chromatography company, we are proud to have delivered innovations in the GC Accessories area. The most recent SGE innovation is SilFlow™, a microchannel fabricated microflow solution.

SilFlow™ compliments products such as the Olfactory Detector Outlet (splitting of the outlet stream for fragrance or odor analysis), AirSharp™ (peak focusing without the need for liquid CO₂ or N₂), and Pyrojector II™ (pyrolysing injection system). The SGE GC Accessories listed in the following pages **improve the flexibility of your analyses and achieve chromatographic solutions** across a range of applications.

GC Accessories



SilFlow™ Technology

Introducing the latest chromatography solution from SGE – SilFlow™

SGE recognizes the need of today's chromatographers to move from tubing based flow systems to planar microchannel systems to deliver flexible solutions for both gas and liquid chromatography. SilFlow™ is an innovation in design and fabrication of highly efficient and reliable microflow systems. In gas and liquid chromatography it is essential to design microflow systems that minimize dead volumes to achieve maximum chromatography performance.

SilFlow™ is enabled by SGE's design and manufacture capabilities, specifically:

- Laser fabrication
- Wafer bonding
- Metal surface deactivation
- Fluidic design
- Connection systems

SilFlow™ Channel Dimensions

Using SilFlow™ technology, SGE can create precise dimensional control of channels between 25 μm and 800 μm.

SilFlow™ designs can incorporate restrictions (for fluidic logic) and intersections (tees). For more complex configurations, multiple layers of up to 8 channels can be manufactured. Contact your local SGE office if the current SilFlow™ products don't meet your chromatography requirements.

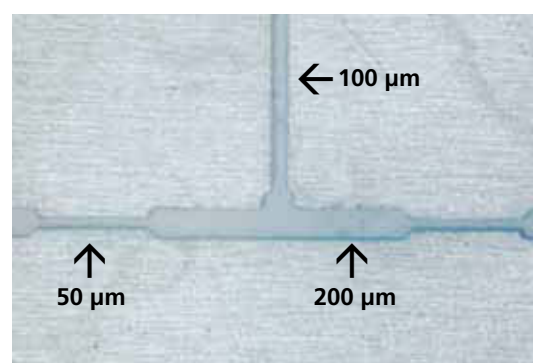

Machined channel orifices in stainless steel layer.

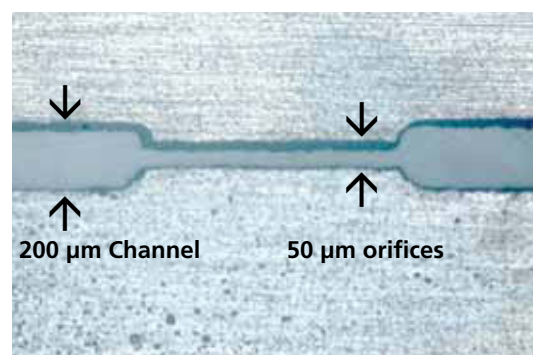

Machined channel orifices in stainless steel layer.

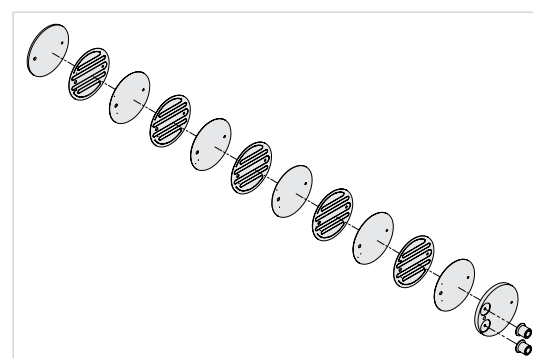

Multilayer channel designs

SilFlow™ Channel Deactivation

The ever increasing sensitivity of analysis in gas chromatography extends to all components in the GC system. SGE's expertise in surface chemistry has developed a series of deactivation technologies to ensure that the metal channels in SilFlow™ exhibit the same inertness as the fused silica capillary columns.

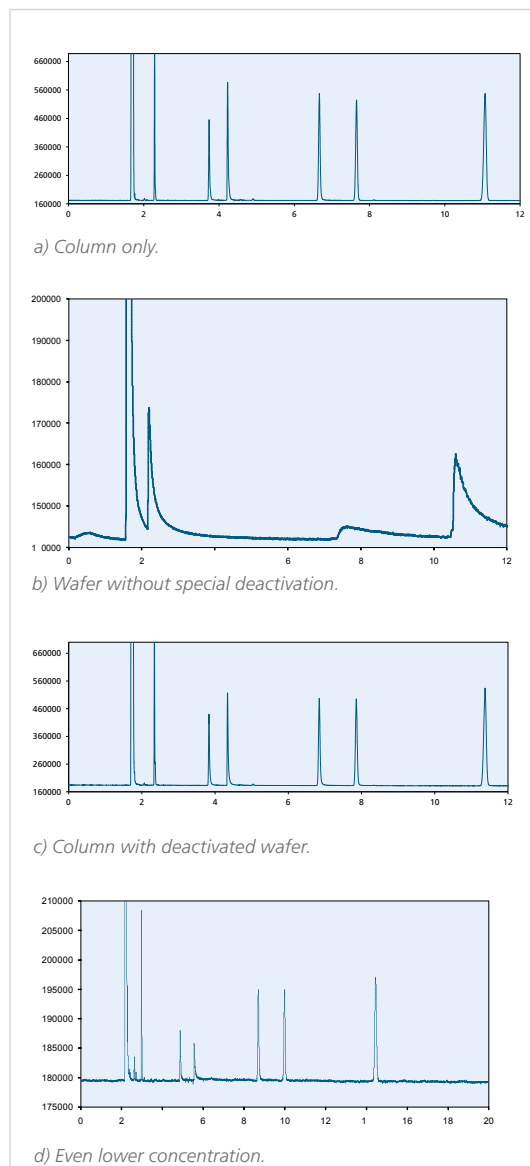

Figure 1.
Column: BPX5 30 m x 0.25 mm ID x 0.25 µm. Column Temp.: 140 °C
FID Temp.: 380 °C Injector Temp. 240 °C. Sample: 1 ng on-column
of test mix (1) n-Decane (2) 4-chlorophenol (3) n-Decylamine (4)
Undecanol (5) Biphenyl (6) Pentadecane.

Improved Chromatography Peak Shape

Because SilFlow™ channels are planar and can be fabricated precisely, ideal microflow arrangements can be designed so that no detectable peak distortion is observed (Figure 1).

SilFlow™ Connection Systems

SGE sought to overcome the challenge of the connection system for microchannel devices, since conventional graphite or Vespel® ferrule systems must not be used as they do not form a perfect seal, and there is the risk of particles from these materials getting into the channels. SGE has invented metal SilTite™ ferrules for use with fused silica tubing, and has adapted this innovation so that metal ferrules can be used with SilFlow™ microchannel systems (Figure 2). Wrenches are not required for a perfect reliable seal, even for the most sensitive MS systems, making SilFlow™ installation simple. Depending on the type of connecting tubing used, the SilFlow™ system can be operated at pressures up to 50,000 psi (3,500 Bar), contact SGE for further details.

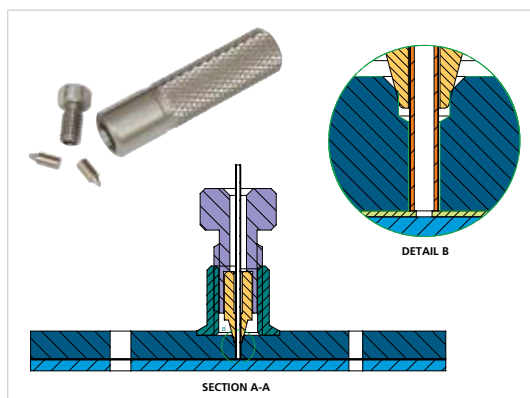

Figure 2. Fused silica to wafer connection system using SilTite™ FingerTite metal ferrule.

SilFlow™ systems are available with two different connection configurations:

- **Holder Based System** - With this connection system the SilFlow™ microchannel wafer is located in a holder to which the tubing connections are made. This system is useful when the wafer is changed regularly or in applications where the wafer could be damaged in use through use of aggressive chemicals or severe contamination. The wafer can be changed quickly and economically.



- **Direct Connection** – Connections can be made directly onto threaded bosses incorporated onto the microchannel wafer, refer to the images on page 185.

SilFlow™ Flexible Fabrication Techniques

SGE understands that SilFlow™ technology is broadly applicable to many areas and that the possibilities in multidimensional chromatography applications are endless.

Therefore, in addition to tees and multi-dimensional systems, SGE makes SilFlow™ technology available to our customers who have a need for a particular microchannel design. The process and design of components is flexible enough to make custom microflow systems quickly and economically. To discuss your microflow system requirements, contact your local SGE office.

SilFlow™ Configurations

The first application of SilFlow™ technology is for a range of 3 Port for HPLC (see page 231), 3 and 4 port splitters for GC. Possible SilFlow™ configurations are demonstrated on page 185.

Enabling GC x GC

To improve analyte detectability and deliver a high separation capacity, complex samples can be analyzed using a comprehensive two-dimensional GC technique (GCxGC). It is applicable to many samples across the industries outlined within this selection guide. For your GCxGC needs, contact your local SGE office.

GC Accessories | Splitters

Splitting in Chromatography can best be defined through Column splitting and Detector splitting.

Column Splitting

Column splitting facilitates concurrent chromatograms to be produced from the same sample (using columns of different selectivity).

It is the technique of diverting fractions of the sample vapor eluting from the inlet to more than one column and associated detector. The carrier gas flow rate through each column and into each detector is defined by the length and diameter of each column and the applied common mid-point pressure. In most instances it is convenient

to use columns of the same length and internal diameter so that optimum flow rates are easy to establish for each column.

Detector Splitting

Detector splitting is best used for complex samples that contain analytes with functional groups that can be selectively monitored by different detectors. The splitting enables simultaneous chromatograms to be produced by the same column and injection.

Detector splitting can be defined as diverting fractions of the column effluent to more than one detector. This technique has only one column that is connected between the injector and the splitting device. The split ratio (relative amount of the sample reaching a detector)

is defined by the length and diameter of the restrictor tubing used, and is proportional to the flow rate down the restrictor. The range of split ratios can be extended by using a midpoint carrier gas supply.

SGE manufactures several styles splitters including inlet and outlet splitters. All of SGE's splitters have an inert flow path, irrespective of whether they are glass lined or stainless steel.

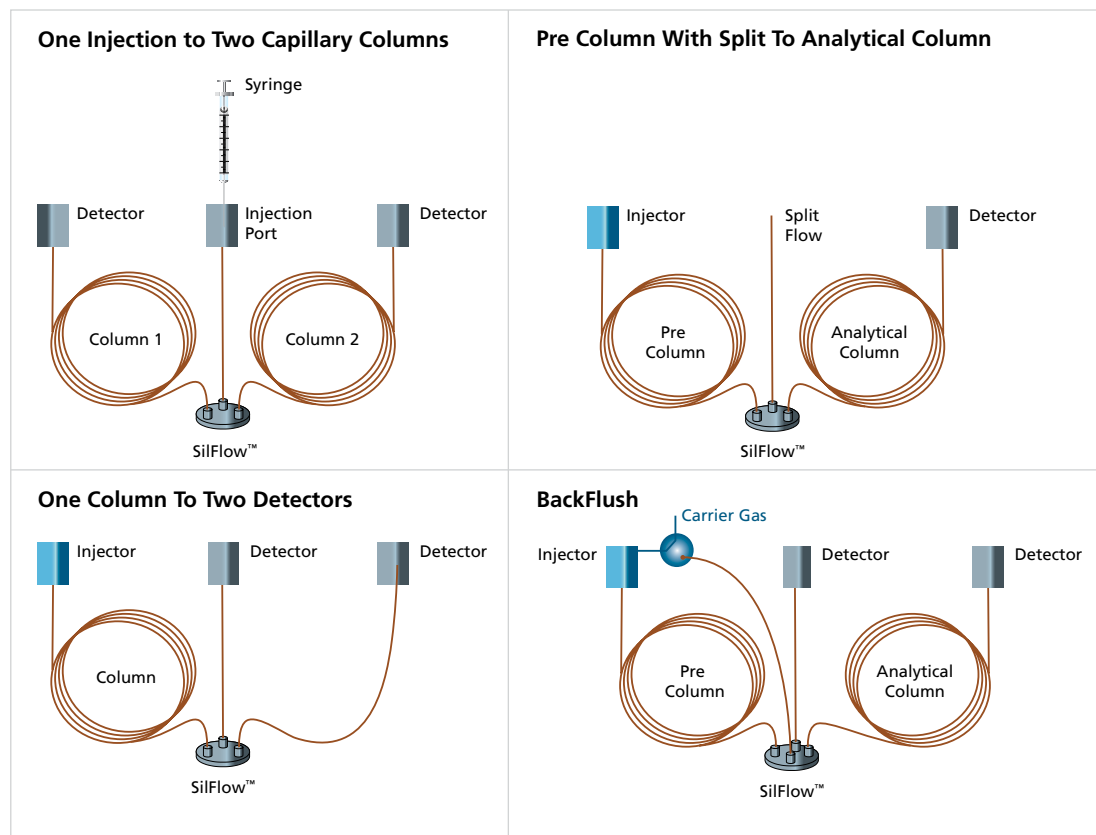

SilFlow™ Configurations



SilFlow™ 3 Port

SilFlow™ 4 Port

GC Deans' Switch

SilFlow™ Kit Contents

Each kit comes complete with: MCD, Fingertite tool, Mounting bracket, appropriately sized ferrules and nuts and blanking ferrules to assist with set up.

Description	Tubing Dimensions					Pack Size	Part No.
	Port A	Port B	Port C	Port D			
SilFlow™ GC 3 Port Splitter							
GC Kit (1.1)	1.1 mm OD	0.25/0.32 mm ID	0.25/0.32 mm ID	–	–	Kit	123720
GC Kit (0.53)	0.53 mm ID	0.25/0.32 mm ID	0.25/0.32 mm ID	–	–	Kit	123721
GC Kit (0.25/0.32)	0.25/0.32 mm ID	0.25/0.32 mm ID	0.25/0.32 mm ID	–	–	Kit	123722
SilFlow™ GC 4 Port Splitter							
GC Kit (1.1)	1.1 mm OD	0.25/0.32 mm ID	0.25/0.32 mm ID	0.25/0.32 mm ID	–	Kit	123730
GC Kit (0.53)	0.53 mm ID	0.25/0.32 mm ID	0.25/0.32 mm ID	0.25/0.32 mm ID	–	Kit	123731
GC Kit (0.25/0.32)	0.25/0.32 mm ID	0.25/0.32 mm ID	0.25/0.32 mm ID	0.25/0.32 mm ID	–	Kit	123732
SilFlow™ GC Deans Switch							
Description	Column 1	Column 2	Detector	SW1	SW2		
GC Kit	0.25/0.32 mm ID	0.25/0.32 mm ID	0.25/0.32 mm ID	1.1 mm OD	1.1 mm OD	Kit	123703

SilFlow™ MCD's, replacement parts, compatible deactivated tubing, and auxiliary stainless steel tubing also available check www.sge.com for specifications and part numbers or contact your local SGE office.

Traditional Splitters

Fixed Inlet Splitter for Capillary Columns

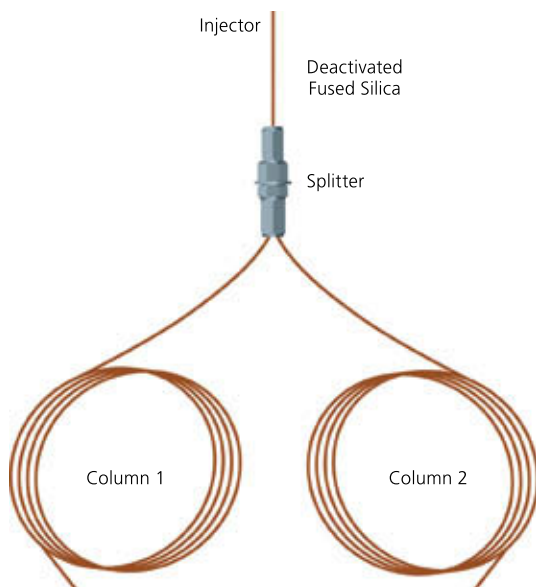

A relatively simple way of achieving a simultaneous two column analysis is to make a single injection and split the sample between two columns with different phase selectivity. The inlet splitter carries out this function and 3 kits are available which suit 0.25, 0.32 and 0.53 mm ID capillary columns. The kits consist of a special Glass Lined Union, a length of uncoated, deactivated fused silica and ferrules.

- Splits an injection between two capillary columns.
- Fixed split ratio.
- Splitter is supplied complete with tubing, ferrules and nuts required for installation.
- Excellent for confirmation of retention data (e.g. pesticide analysis).
- Inert glass lined tubing (GLT™) flow path.
- Low dead volume.
- Can be used for all capillary columns (0.1-0.53 mm ID).

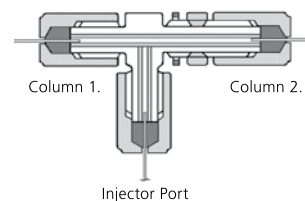

Description	Column OD	Column ID	Pack Size	Part No.
Fixed Inlet Splitter for Capillary Column	0.32-0.36 mm	0.1-0.25 mm	1	123632
Fixed Inlet Splitter for Capillary Column	0.45 mm	0.32 mm	1	123633
Fixed Inlet Splitter for Capillary Column	0.78 mm	0.45-0.54 mm	1	123634
Replacement Ferrules				
0.1-0.25 mm (2-hole ferrule)	0.32-0.36 mm	0.1-0.25 mm	10	072662
0.32 mm (2-hole ferrule)	0.45 mm	0.32 mm	10	072664
0.45-0.53 mm (1-hole ferrule)	0.78 mm	0.45-0.54 mm	10	072655

Fixed Outlet Splitter for Capillary Columns



The outlet splitter allows the analytes from a capillary column to be split between two different detectors. The ratio of flow to each is controlled by adjusting the lengths and/or ID of splitter tubing. The basis of the splitter function is the pressure drop across each of the splitter tubes.

As a general rule in selecting splitter tubing for capillary columns, the combined internal areas of the splitter tubing should be approximately 70% – 80% of the internal area of the capillary column. Once this criterion has been satisfied, the lengths of the splitter tubing should be as short as possible to minimize the overall pressure drop.

- Designed for splitting the flow from one capillary column to two detectors.
- Glass Lined Tubing (GLT™) splitter union for inertness.
- Splitter is supplied complete with tubing, ferrules and nuts required for installation.
- Can be used for 0.1-0.32 mm ID capillary columns.
- For an outlet splitter for 0.53 mm ID columns, Part No. 123634 is recommended.

$$f = \frac{l_1}{l_2} \frac{P_2}{P_1} \left(\frac{r_2}{r_1} \right)^4$$

Where:

- l_1 = tube length in cm of length 1
- R_1 = tube radius in cm of length 1
- P_1 = pressure drop across length 1
- l_2 = tube length in cm of length 2
- R_2 = tube radius in cm of length 2
- P_2 = pressure drop across length 2
- f = flow rate through tube 2 relative to flow rate through tube 1 (5:1 or 0.20)

If both detectors are atmospheric, the P factors drops out of the equation.

Tubing dimensions:

- 1:1 2 x 1 m lengths of 0.22 μ m.
- 1:5 1 m of 150 μ m and 1 m of 220 μ m.
- 1:10 1 m of 110 μ m and 1 m of 220 μ m.

Description	Split Ratio	Pack Size	Part No.
Fixed Outlet Splitter for Capillary Columns	User Determined*	1	123630
Fixed Outlet Splitter for Capillary Columns	User Determined***	1	123634
Fixed Outlet Splitter for Capillary Columns	1:1**	1	1862460
Fixed Outlet Splitter for Capillary Columns	1:5**	1	1861461
Replacement Tubing			
	1:1**	2	18614600
	1:5**	2	18614610
	1:10**	2	18614620
Replacement 2-Hole Ferrules			
	0.1-0.25 mm ID		072662
	0.32 mm ID		072664

* Includes 5 meter length of 0.22 mm ID deactivated fused silica tubing. ** Includes fused silica tubing pre-fused into a 2-hole ferrule for preset split ratios. *** Includes 5 meter length of 0.53 mm tubing ID deactivated fused silica tubing.

Variable Outlet Splitter for Capillary Columns

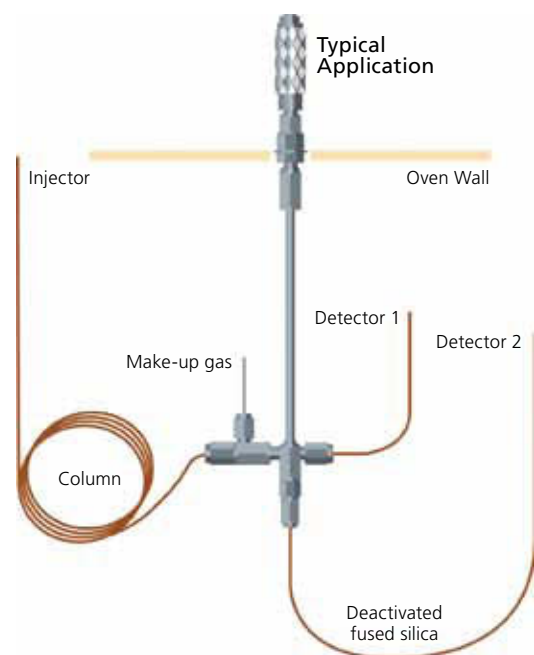

This outlet splitter system can be used with all flexible fused silica capillary columns from 0.10 to 0.53 mm ID. The micro control valve provides a continuously variable range of split ratios, and using different length and ID tubing increases the split ratios achievable. Closing off the valve closes the base outlet only, full flow remains through the side arms. A make-up gas tee piece is built into the valve which eliminates potential dead volume problems and allows detector linearity to be maintained.

- Regulates flow from one capillary column to two detectors.
- Make-up gas tee piece built into the valve to increase flow velocity thus eliminating potential dead volume problems.
- Detector sensitivity is maintained.
- Valve control is located outside the GC oven while all parts of the flow path are inside the oven eliminating condensation problems.

Description	Pack Size	Part No.
Variable Outlet Splitter for Capillary Columns	1	1236291

For your GC tubing needs, go to the tubing section starting on page 233.

Micro-control valves can be used for a wide range of applications in chromatography, as well as analytical science. Generally, micro needle valves are used for fine control of gas or liquid flows. Most valves can be used at elevated temperatures over a wide range of pressures from high vacuum to a few atmospheres.

Two basic configurations exist in the valve product range – an “L” and a “T” configuration (Figure 1).

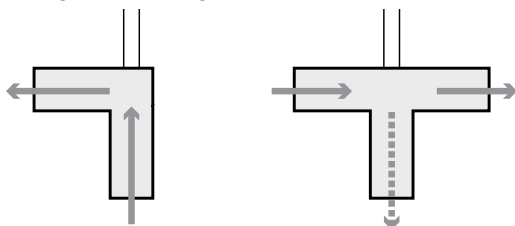

Figure 1: “L” and a “T” configuration.

If the application requires in line, on/off control or metering of a single gas stream, choose an “L” configuration, i.e. BMCV, MCV, MOVP, MOV or SMOV.

If the application requires diversion or splitting from the main stream of gas to another column or detector and so on, choose a “T” configuration, i.e. MOVT, MOVPT or MCVT.

NOTE: In all valves of the “T” configuration, flow through the cross arms continues whether the valve is “open” or “closed”. Metering only occurs on the vertical arm when the valve is opened will depend on the relative restriction in the flow lines downstream of the valve.

Effect of Viscosity

The flow of a gas through an orifice is affected by its viscosity. Different gases have different viscosities and so the flow through valves will vary according to the gas being used.

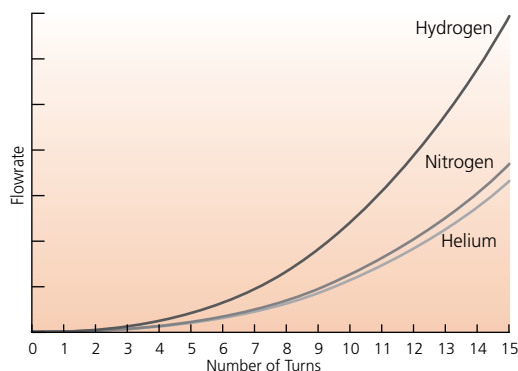

Effect of Temperature on Flow

As the temperature of a gas is raised, the collisional frequency of the gas molecules rises and the effective viscosity of the gas increases. While the effect varies from one gas to another, the overall effect is that increasing the temperature decreases the anticipated flow through the valve.

Valve Specifications

SGE valve codes are descriptive and can be explained as follows:

M	Micro valve
O	On/off style
C	Control/metering style
V	Valve
P	Pneumatic operation
T	“T” configuration
PP	Push/push pneumatic operation
50/100	Refers to the stem length

- Valve body temperature rated to 300 °C, except for Brass Micro Control Valve (BMCV) and Stainless Manual On/off Valve (SMOV) which are rated to 100 °C.
- Vacuum rated to a leak rate of 1×10^{-8} cc/sec of Helium, except for BMCV and SMOV which are not tested in this application.
- Pressure rated to 35 atmospheres (500 psi) (most), depending on direction of flow, except for SMOV which is rated to 400 atmospheres (5500 psi).
- Flow path fully swept.
- Virtually no dead volume, with minimal exposure to stainless steel.
- Replaceable graphitized Vespel® seat.
- Range of stem lengths where appropriate.
- Easy installation. Maintenance instructions, spare seals and seats are provided with each unit.

High Performance ON/OFF Valves

MOVT valves provide a quick and positive on/off response under high vacuum or pressure. This is suitable for solvent dumping. 1/16" OD flow lines or fused silica lines can be used.



Configuration / Material	Length / Connection	Temp Rating	Vacuum Rating	Pressure Rating	Flow Rating	Valve Code	Part No.
T Dual Outlet, Stainless Steel	50 mm, 1/16"	300 °C	Yes	500 psi	n/a	MOVT	1236071

GC Accessories

Pneumatic Control ON/OFF Valves

The MOVPT and MOVPT valves have a similar design to the MOVT except with these valves, the on/off function is actuated pneumatically. The pneumatic head assembly, which can be actuated remotely with a toggle switch or solenoid valve, is operated from a 50-55 psi air supply.



Configuration / Material	Length / Connection	Temp Rating	Vacuum Rating	Pressure Rating	Flow Rating	Valve Code	Part No.
L Single Outlet, Stainless Steel	50 mm, 1/16"	300 °C	Yes	500 psi	n/a	MOVPT	1236091
T Dual Outlet, Stainless Steel	50 mm, 1/16"	300 °C	Yes	500 psi	n/a	MOVPT	1236103
T Dual Outlet, Stainless Steel	100 mm, 1/16"	300 °C	Yes	500 psi	n/a	MOVPT(L)	1236104

High Performance Flow Control Valves



High performance flow control valves MCV and MCVT valves have a fine tapered needle to give precision control through a wide flow range, to complete shut off. Ten turns provides control from fully open to fully closed for complete shut off.

GC Accessories

Configuration / Material	Length / Connection	Temp Rating	Vacuum Rating	Pressure Rating	Flow Rating	Valve Code	Part No.
L Single Outlet, Stainless Steel	50 mm, 1/16"	300 °C	Yes	500 psi	0-2000 mL/min	MCV	1236012
L Single Outlet, Stainless Steel	100 mm, 1/16"	300 °C	Yes	500 psi	0-2000 mL/min	MCV	1236020
T Dual Outlet, Stainless Steel	50 mm, 1/16"	300 °C	Yes	500 psi	0-2000 mL/min	MCVT	1236032

Low Cost Stainless Steel ON/OFF Valves



The SMOV compact stainless steel on/off valve is ideal for use as an isolation/shut off valve. Suitable for solvent dumping. 1/16" OD flow lines or fused silica lines can be used. Can be used at temperatures from ambient to 100 °C, ideal isolation/shut off valve.

Configuration / Material	Length / Connection	Temp Rating	Vacuum Rating	Pressure Rating	Flow Rating	Valve Code	Part No.
Single Outlet, Stainless Steel	1/16"	100 °C	No	5500 psi	n/a	SMOV	1236283

For your GC tubing needs, go to the tubing section starting on page 233.

Low Cost Stainless Steel Control Valves



The BMCV, an inexpensive mini-valve, is ideal for on-line micro control for elevated pressures to 6 atmospheres (90 psi), and temperatures from ambient to 100 °C. This valve is ideally used for septum purge and non-precision flow control. The valve accepts 1/16" OD flow lines.

The BMCV-1 has been the "work-horse" of the SGE injector kits and control modules for many years. Depending on the gas, it can provide smooth flow metering up to 2 liter/min (Figure 1).

The BMCV-A is similar to the BMCV-1, but the finer taper allows for smooth control in the range from 0-250 mL/min (Figure 2).

An inexpensive kit (P/N 1034606) is available to adapt SGE micro valves to accept fused silica capillary columns or tubing. The kit consists of inserts to reduce the bores of the connecting arm plus special nuts and ferrules.

GC Accessories

Experimental Data BMCV-1 Valves

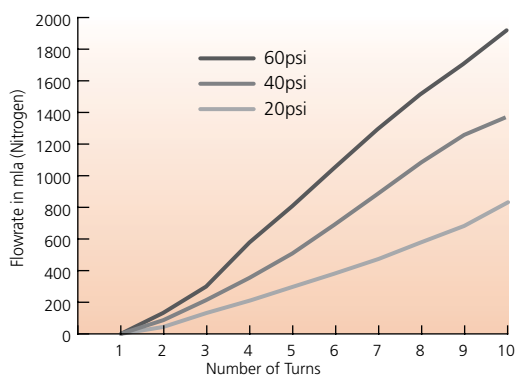

Figure 1.

Experimental Data BMCV-A Valves

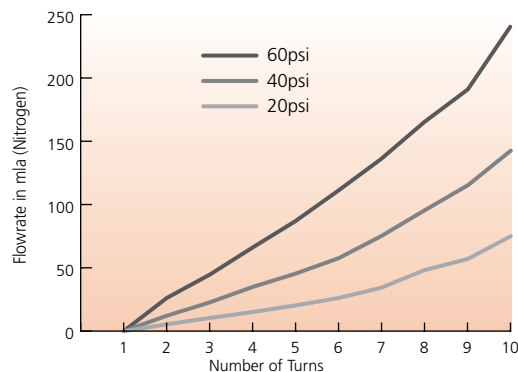

Figure 2.

Configuration / Material	Length / Connection	Temp Rating	Vacuum Rating	Pressure Rating	Flow Rating	Valve Code	Part No.
Single Outlet, Brass	1/16"	100 °C	No	500 psi	0-200 mL/min	BMCV-A	1236281
Single Outlet, Brass	1/16"	100 °C	No	500 psi	0-2000 mL/min	BMCV-1	1236282

Adaptor Kit

Description	Connection	Pack Size	Part No.
Adaptor Kit for connecting fused silica capillaries to SGE Micro Valves. Contains: ferrules (pk 5), instructions, nuts (pk 3) and conversion glass lined tubing (GLT™).	1/16"	1	1034606

Re-order Part Numbers for Replacement Parts for Micro-control Valves

Description	Pack Size	Part No.
Seal-seat Removal Tool	1	1236101
PTFE MV Seals	2	123687
VSV-6 Vespel® Valve Seat	5	123681
PEEK™ Valve Seat for SMOV Valves	5	123683
GFF16-16 Graphite Ferrules	10	072603
GVF16-16 Vespel® Ferrules	10	072657
PSR16-16 PTFE Sealing Rings	20	072650

Increase sensitivity without changing columns

Sample Focusing

Cold traps are used to increase sensitivity without altering the method. Cold traps improve the signal-to-noise ratio and increase the detection limit of an analysis. When a peak is focused, or 'trapped', its bandwidth decreases significantly causing the sample to concentrate in a very small area of the capillary column. The result is a very sharp peak that has a high signal-to-noise ratio.

How do cold traps work?

A cold trap works by cooling a very small area of the capillary column. Cooling causes the sample to spend more time in the stationary phase, which slows it down. As a sample peak approaches the cold spot, the leading edge of the sample band will travel slower, and eventually the trailing edge will catch it. The sample band becomes very narrow and the cooling is then turned off, releasing the narrowed sample peak. An example of this process is shown in Figure 1.

Where to trap? At the start or end of the column?

For long splitless injections, Purge & Trap and SPME, cold traps are used at the beginning of the column to reduce band broadening created by the long injection time. A cold trap placed at the start of the column also allows higher oven starting temperatures to be used, decreasing analysis cycle times.

A cold trap placed at the end of the column can be used to sharpen up individual peaks before they reach the detector. This is particularly useful on long runs with trace analysis, where signal-to-noise ratios can be increased 100 times.

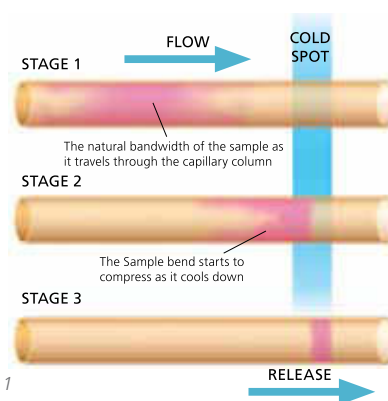

Figure 1

GC Accessories | Cryogenic Cold Trap

The Cryogenic Cold Trap is suitable for trapping / focusing samples in a narrow band on the column. The trap operates by cooling a short section of the column and is designed to be easily cooled or reheated to allow excellent peak shape and reproducibility.

- Suitable for focusing components in a narrow band on the column.
- Improves peak shape.
- Suitable for purge and trap, on-column trace enrichment, air and gas sampling, head-space analysis and multidimensional techniques.

Features:

- Can hold components with boiling points equivalent to C_7 for 20 minutes even at oven temperatures of 300 °C.

- Cold trap tee with a pneumatic head switching valve.
- Toggle switch for compressed gas.
- All ferrules needed for operation are supplied.
- All necessary tubing, fittings and tools required for installation are supplied.



Substituted Benzenes

Phase: **BP624**
 Column: **60 m x 0.5mm ID**
 Initial Temp: 30 °C, 1 min
 Rate: 5 °C/min
 Final Temp: 190 °C, 5 min

Detector: FID
 Injection
 Mode: SGE CHIS
 (concentrator/
 headspace)

Components

- | | |
|-----------------|----------------------|
| 1. Benzene | 6. n-Propylbenzene |
| 2. Toluene | 7. tert-butylbenzene |
| 3. Ethylbenzene | 8. iso-butylbenzene |
| 4. p-Xylene | 9. sec-butylbenzene |
| 5. o-Xylene | 10. n-butylbenzene |

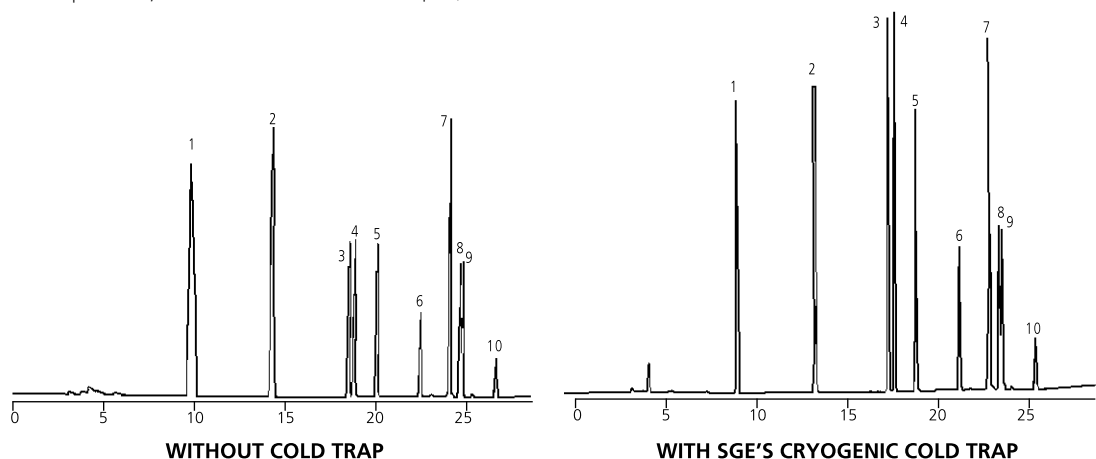

GC Accessories

Description	Pack Size	Part No.
Liquid CO ₂ Cryogenic Cold Trap	1	093346

Replacement Parts

Description	Pack Size	Part No.
1/16" Brass Nut	5	103404
Replacement Filter	1	0933424
1/16" Stainless Steel Nut	5	103403

GC Accessories | Capillary Washing/Coating Reservoir

- Ideal for washing cross-linked/bonded phases.
- Enables unattended washing of contaminated columns by pushing solvent through under gas pressure.
- Can be employed for custom coating of capillary phases.

Description	Pack Size	Part No.
10ml Washing / Coating Reservoir	1	0625026
Replacement Parts	PTFE 1/16" Sealing Ring	20 072650



Expert Tip :

Suitable Solvents for Capillary Column Rinsing.

All BP, BPX and HT stationary phases

- Paraffins; pentane - octane
- Chlorinated paraffins; methylene chloride, chloroform, carbon tetrachloride
- Aromatics; toluene, ethyl benzene, xylenes
- Alcohols*; methanol, ethanol
- Ketones; acetone, MEK

- Ethers; diethyl ether
- Esters*; methyl acetate, ethyl acetate

* Alcohols are recommended for polyethylene glycol based phases (BP20, BP21) only. Water can also be used for column rinsing but only in conjunction with alcohols for these bonded phases.

* Although suitable for column rinsing, chlorinated solvents are preferred as acetates can extract some cross-linked phases.



Expert Tip :

FID temperature should always be above the oven temperature to prevent condensation of the sample or stationary phase in the detector.



GC Accessories

Expert Tip :

For maximum FID sensitivity, set the air flow 10 times higher than the hydrogen flow.



The flame ionization detector (FID) uses a flame source to ionize compounds, it is the most commonly used GC detector. The FID is mass flow dependent, and is used when analyzing compounds (including all organic compounds) that ionize in a hydrogen and air flame. It is commonly used in the environmental, food flavor and fragrance, petrochemical industries. Because of this, it is considered a universal detector, however inert gases, oxygen, nitrogen, carbon dioxide and carbon monoxide produce limited response, and non linear responses are common for heavily halogenated compounds due to the low number of C/H bonds.

When a sample combusts in a hydrogen/air flame and ionizes, the signal is produced. Being a mass sensitive detector the FID responds to the amount of material passing through the flame at a given time, which is directly proportional to the amount injected. FID jets have different tip dimensions: the smaller tips are ideal for analysis where high sensitivity is desired (<0.25 mm ID); general purpose analysis uses a medium tip size; and for analysis using thick film columns the larger tip sizes are recommended (as the smaller and medium sized tips are inclined to block).

Limitations of detection occur when compounds are below the baseline noise (column bleed, gas contaminants and electrical noise). The detector has reached its maximum linear range when an increase in sample concentration no longer correlates with an increase in response.

Maintenance of your FID

Contamination of your FID can occur from sample residue and stationary phase bleed. Evidence of contamination can be white silica powder around the jet which leads to increased background noise. High levels of contamination will cause noise spikes due to silica particles entering the flame. As a result of noise building, sensitivity reduces.

If excessive tailing or adsorption occurs, it is likely that fused silica has broken off in the jet tip. This commonly occurs during column installation, and can be rectified by removing the jet and cleaning out the jet with standard cleaning kits. After reassembly, ensure the detector temperature reaches 150 °C prior to installing a column which will prevent any water from being present.

FID Flame Jet Upgrade

Agilent Technologies

SGE's inert glass lined FID and NPD jets for Agilent Technologies gas chromatographs eliminate sample contact with metal, enabling non-critical positioning of the capillary column in the jet.



Description	Temperature (°C)	Length (mm)	Tube ID (mm)	Tip Dimension (mm)	Part No.
Glass Lined Flame Jets 5890	400 °C	61.3	0.9	0.35	103474
Glass Lined Flame Jets 6890	400 °C	42.3	0.9	0.35	103475
High Temperature Flame Jets 5890	450 °C	61.3	1.1	0.43	103479
High Temperature Flame Jets 6890	450 °C	42.3	1.1	0.43	103477

Varian/Bruker & Antek

High purity, inert fused silica flame jets enable replacement of existing ceramic and metal jets, effectively eliminating the jet as a source of activity and peak tailing.

Description	Part No.
FID Flame Jet for Varian/Bruker Instrument Models 3300, 3400, 3500, 3600 & 3800	103469
FID Flame Jet for Antek Instruments	103470

GC Accessories | Capillary Cutting Tools



- Burr-free cutting of fused silica tubing.
- Reduces likelihood of blockages.
- Ensures square ends for “press fit” style connectors.
- Clean entry for on-column injection.

Description	Pack Size	Part No.
Capillary Cutting Tool	1	0625010
Capillary Ceramic Tube Cutter	3	0625011

GC Accessories | Retention Gap Kits

- Protects the capillary column from sample contamination.
- Improves peak shape with splitless injection.
- Enables on-column injection into a wide bore (0.53 mm ID) retention gap.
- Ideal for cryogenic cold trapping, especially with columns with high minimum temperature limits, e.g. useful for trapping components at -30 °C when using a column with a minimum temperature of 20 °C.

- Kit is supplied with deactivated fused silica (2m length), mini union and ferrules.



Description	Column ID	Pack Size	Part No.
Retention Gap Kit	0.22 mm – 0.32 mm	1	052295
	0.53 mm	1	052296

GC Accessories

GC Accessories | Gas & Vapor Field Sampler

The Gas and Vapor Sampling Kit (GAV-200) is ideal for remote sampling of environmental or low pressure stream gases and vapor. Samples are collected in a 200 mL self-sealing, impervious bag which can be removed from the sampling canister for further sampling. The filled bags can be stored until discharge of the contents is required.

- Easy to use.
- Ideal for field environmental analysis.
- Resealable / removable sample bags.
- 200 mL sample bag capacity.

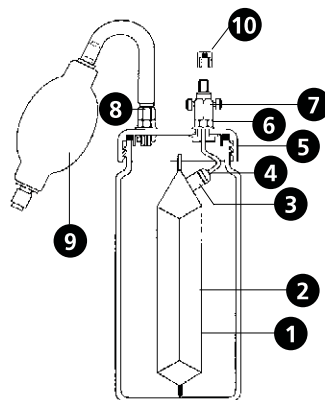

1. Canister
2. Removable Sample Bag
3. Self-sealing Septum
4. Coupling Tube
5. Canister Cap
6. Sealing Ring
7. Gas Valve
8. Pressure Fitting
9. Aspirator Bulb
10. Source/Discharge Connecting Nut

Description	Pack Size	Part No.
Gas and Vapor Sampling Kit	Canister and Bulb, 10 bags	090111
Replacement Parts:		
• Sample Bags	10	090112
• Septa	5	090113
• PSR16-16 PTFE Sealing Ring	20	072650



GC Accessories | Soap Bubble Flow Meter



- Gas flow rates from 0.01 to 500 mL/min.
- 100 µL up to 50 mL capacity.
- Easy-to-read scale.

Description	Capacity	Part No.
Bubble Flow Meter	100 µL	062505
	500 µL	062506
	50 mL	062503
Rubber Bulb for Soap Bubble Flow Meter	50 mL	0625031

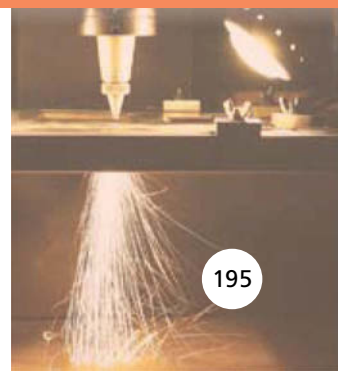



HPLC Columns and Applications

Choosing the Right HPLC Column for Your Application	198-202
HPLC Column Selection Tree	203
ProteCol™ Product Range and Part Numbers	
ProteCol™ HPLC Analytical Columns	204
ProteCol™ HPLC Capillary Columns	205
ProteCol™ HPLC Capillary Trap Columns	205
ReproSil™ HPLC Capillary Trap Columns	205
ProteCol™ HPLC Guard Columns	206
ProteCol™ HPLC Capillary Guard Columns	206
HPLC Applications by Industry	207-215

Following production, ProteCol™ HPLC columns are individually tested and packaged with test certificates.

The Role of Pore Size in Reversed Phase HPLC

SGE is excited to launch a new HPLC product line under the ProteCol™ brand.

Fundamental to the new ProteCol™ line of columns is the continued focus on inert column design that was first created with the ProteCol™ PEEKsil™ offering (polymer - sheathed fused silica tubing). SGE is excited to offer a new range of ultra pure reversed phase silicas in both the unique GLT™ (glass lined tubing) column format as well as a new PEEK™ lined stainless steel format. The benefit is the most comprehensive inert HPLC reversed phase column offering from the 150 micron ID PEEKsil™ format through to the new 4.6 mm ID PEEK™ lined stainless steel columns.

most chromatographers expect that the silica sourced by manufacturers is of the highest purity and SGE confirms we have rigorously researched the quality of silicas using the standard reference material (SRM) provided by the National Institute of Standards & Technology. Testing of silicas using SRM 870 (NIST) identifies non-specific interactions associated with metal contamination as well as non-end capped silanols (see Figure 1).

What is often not considered is the role column hardware may play in non-specific interactions – the frit and internal column hardware can both influence the behavior of analytes with known metal chelating activity. Most pharmaceutically active compounds and natural products have the potential to interact with metals. Coordination between the metal ion and the analyte is facilitated by a lone electron pair on the analyte molecule.

If two electron donor groups (either oxygen or nitrogen) are located in a favorable position, a chelate can be formed and while the enthalpy of the complex formation for two monodentate ligands and a bidentate ligand is similar, the chelate is entropically favoured and leads to a stronger interaction. For this reason molecules like quinizarin,

Why is Inert HPLC Column Design Important?

Non-specific interactions between the target analyte and the silica particles in the HPLC column are now well controlled with the availability of ultrapure silicas. Today,

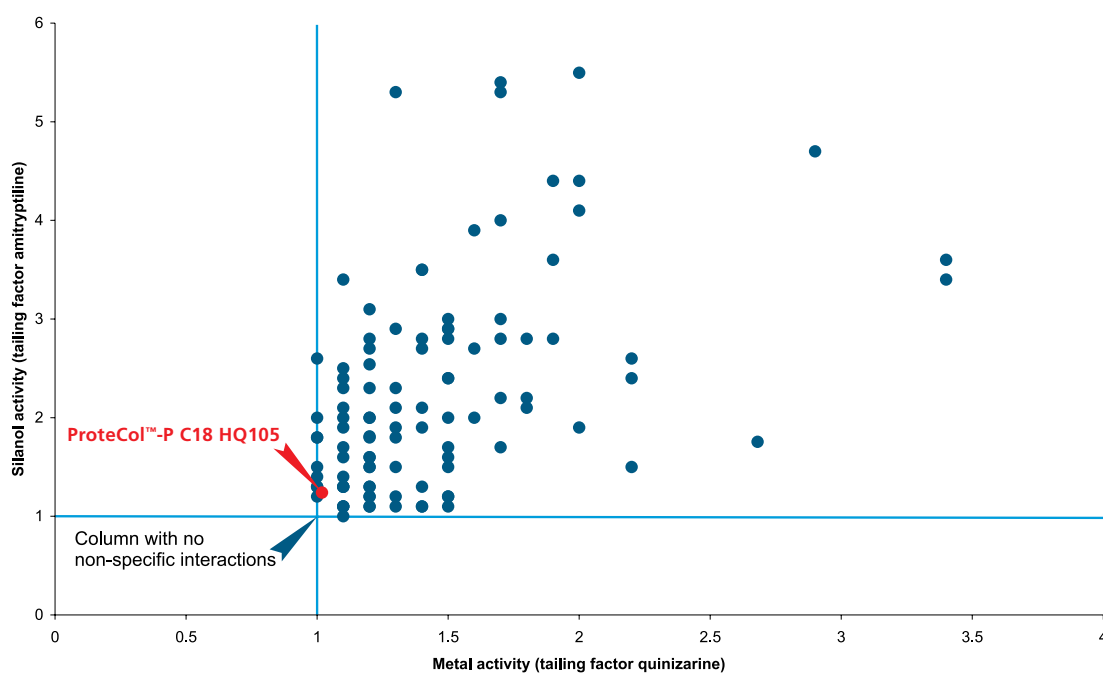

Figure 1: Non-specific interactions of the NIST SRM870 probe molecules on commercially available C18 columns. (Comparison data available at: www.usp.org/USPNF/columns.html)

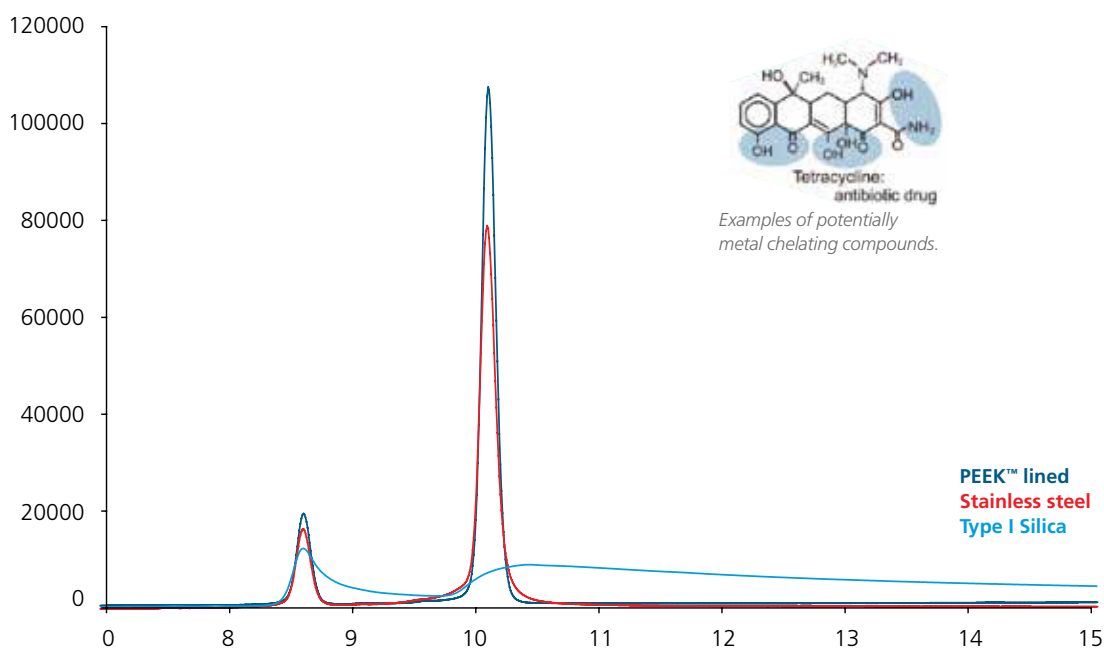

Figure 2: Chromatogram of tetracycline (antibiotic) and its major degradation product. Note the peak broadening on the base of the peak run through the stainless steel column leading to a 25% decrease in sensitivity. Inset: the tetracycline molecule depicting the three potential chelating groups.

tetracycline or ciclopirox form tailing peaks in the presence of metal in the column/system (see Figure 2).

To address this potential risk, SGE's ProteCol™ column development has focused exclusively on the most inert C8 and C18 phases in a variety of pore and particle sizes in the most inert column hardware – glass lined, PEEK™ lined stainless steel (see Figure 3) and PEEKsil™.

Why Focus on Reversed Phase and Pore Size?

Reversed phase chromatography is by far the most commonly used form of liquid chromatography and most chromatographers prefer to stay in the reversed phase environment rather than

move into other less conventional buffer systems.

Alkane modified silicas were developed in the 1970s and because of the better resolution and higher reproducibility, quickly became the most popular separation technique in liquid chromatography. Since the elution conditions and elution order are opposite to what was "normal" chromatography, the term "reversed" phase was coined and has remained the general term describing a hydrophobic bonded stationary phase. When it comes to considering the optimal reversed phase column for the separation of a target analyte, the majority of liquid chromatographers base their selection on the type of bonded phase (C18, C8, C4, Phenyl etc), whether the column is end capped and the overall carbon loading.

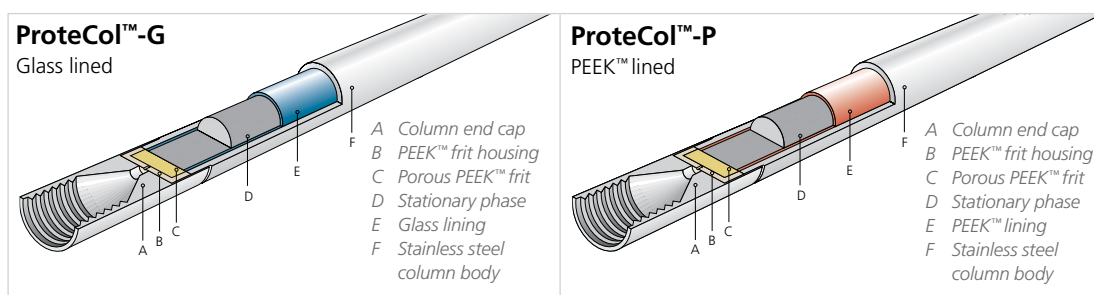

Figure 3. SGE's inert column hardware includes glass and PEEK™ lined stainless steel.

Don't Forget to Choose the Appropriate Pore Size of Your Reversed Phase Column!

What is often ignored by chromatographers is the choice of optimal pore size of the silica for the appropriate application. In liquid chromatography virtually all interactions (and therefore retention) takes place inside the pore system. The exterior surface of common porous silica makes up less than 1 % of the total surface area. In order to use the available interactive surface, the analyte molecule needs unrestricted access to the particle interior. In most chromatographic applications pore diffusion is the time limiting step (the slowest step which therefore governs the overall kinetics). After overcoming the film mass transfer resistance, the solute has to diffuse into the pore system in order to bind to the surface since most of the surface is inside a porous particle (>99 %). For larger molecules such as proteins, pore diffusion becomes a crucial factor.

A number of models have been derived to describe the effect of the pore diameter on the diffusion constant of a solute molecule. These models range from the Fickian

diffusion where the diffusion rate is purely concentration driven (large pores – small solute molecules – the mean free path of the Brownian motion is small compared to the pore diameter); to the Knudsen diffusion, where the mean path of the Brownian motion is equal or larger than the pore diameter (collisions with the wall play a major role in the determination of the diffusion rate). An extreme case is the single file diffusion, where the diameter of the solute molecule is larger than the radius of the pore. In this case molecules are unable to pass each other. In addition, an estimation for the steric hindrance at the pore entrance and the frictional resistance within the pore system was provided by Renkin.

$$D_p = D_f \left(1 - \frac{r_s}{r_p}\right)^2 \left[1 - 2.104 \left(\frac{r_s}{r_p}\right) + 2.09 \left(\frac{r_s}{r_p}\right)^3 - 0.956 \left(\frac{r_s}{r_p}\right)^5\right]$$

D_f = Free molecular diffusion coefficient.

D_p = Diffusion as the coefficient inside the pore.

r_s, r_p = Radii of the solute and the pore respectively.

A graphical representation of the Renkin model and its implications are shown in Figure 4.

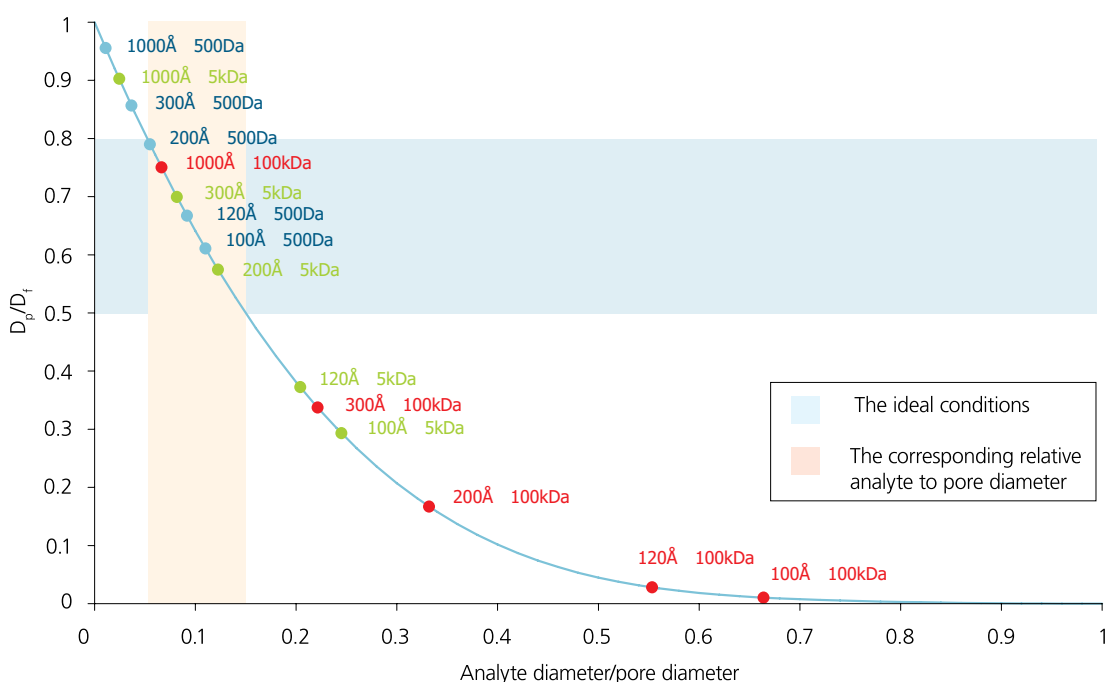

Figure 4: Relative pore diffusion coefficients of large molecules in different pore size stationary phases

The drawback of large pore sizes in HPLC columns is the reduction in specific surface area. As the pore size increases, the accessible surface area for the solute to bind to decreases and with it the capacity of the column. Figure 5 shows the specific surface area of commercially available packing material versus the pore diameter.

The choice of pore size for a given separation is a compromise between resolution on the high pore diameter end and load-ability (capacity) on the low pore diameter end. A rough guide for suitable pore diameter ranges (where the pore diffusion coefficient is between 50 and 80 % of the diffusion rate in free liquid) is shown in Figure 6.

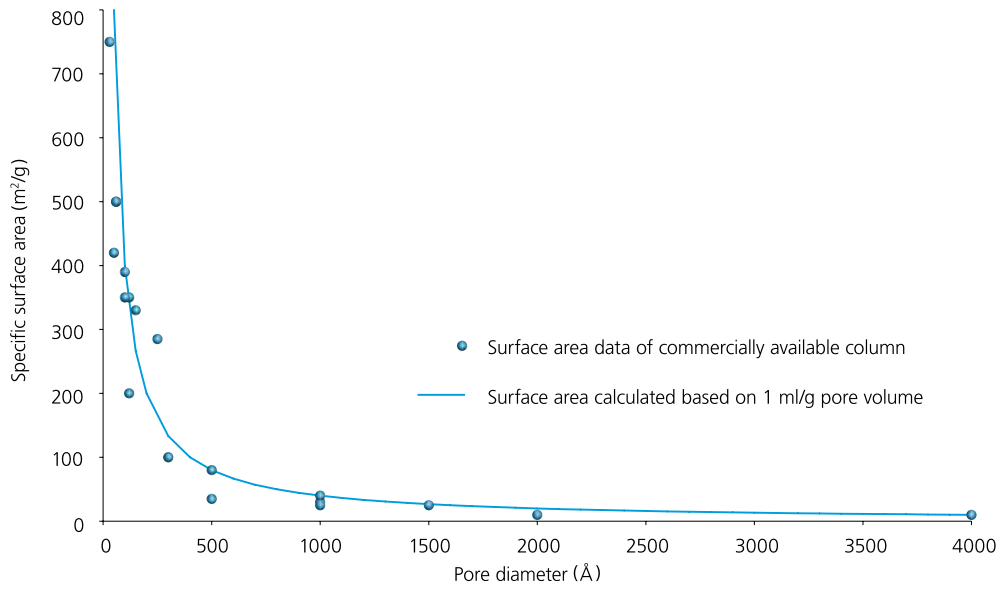

Figure 5. Reduction in column capacity due to increased pore size (blue dots represent published data by various column suppliers)

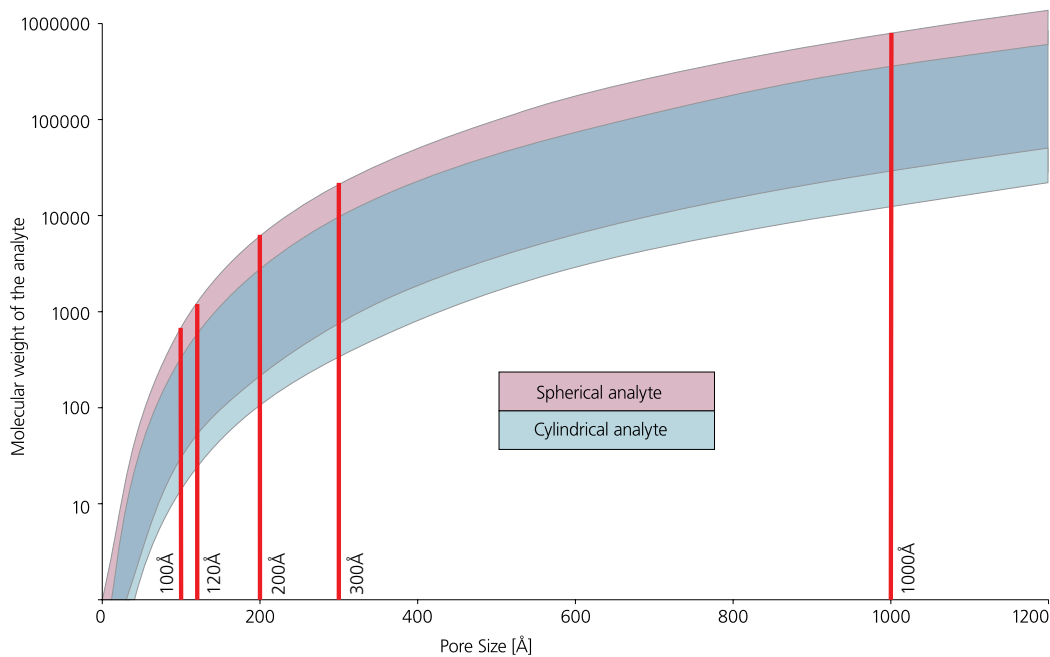

Figure 6: Acceptable molecular weight range of spherical & cylindrical shaped analytes in relation to pore size

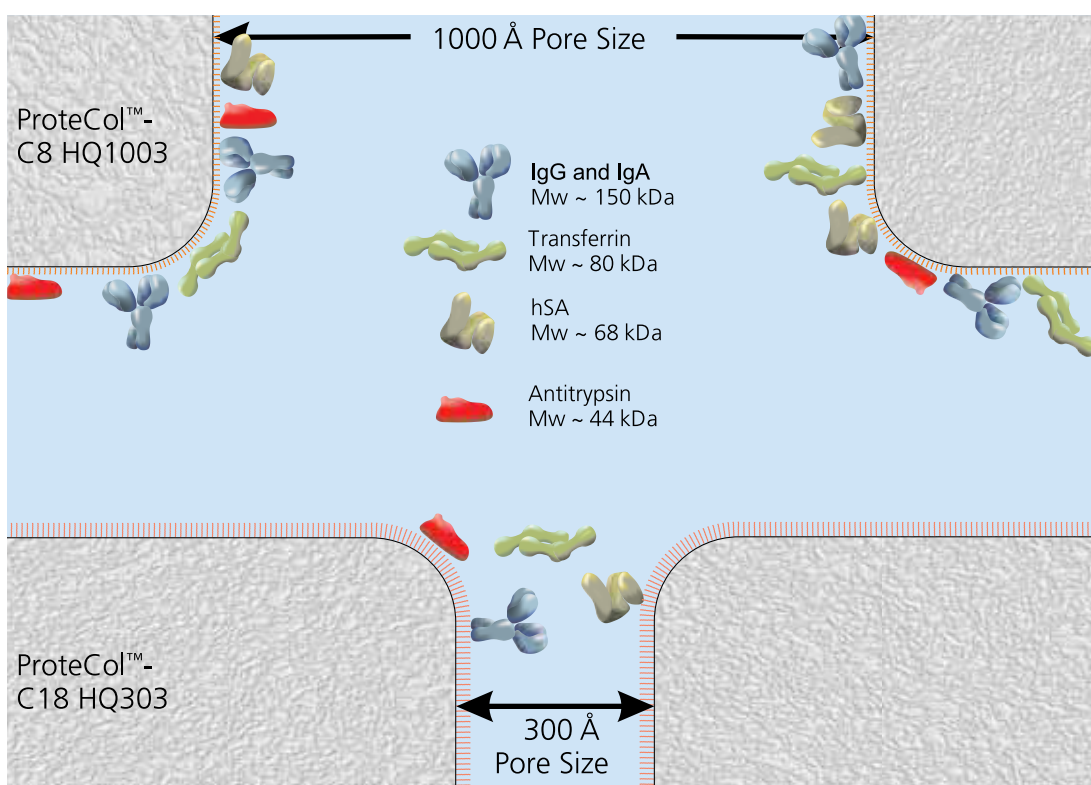

Figure 7: Schematic representation of the relative sizes of the five most abundant plasma proteins.

As Figure 7 suggests, the use of 300 Å pore size stationary phases does not have a practical limit for large molecules and you should be mindful of the sample's complexity before considering the separation of large macromolecules on this type of phase. Proteins are large macro molecules and diffuse slowly (small diffusion rate constant). Proteins are also more likely to cause a steric hindrance once they bind to the pore surface.

In conclusion, SGE recommends the following guide to selecting the appropriate pore size based on your target analytes molecular weight range.

Pore Size	Spherical Analyte		Cylindrical Analyte	
	Lower	Upper	Lower	Upper
100	30	800	13	350
120	50	1,400	23	610
200	240	6,400	100	2,800
300	800	21,400	350	9,500
1000	29,400	800,000	13,000	350,000

Pore Size (Å) Lower and Upper ranges shown in Daltons (Da)

Expert Tips for Small Molecules

Simple DO's and DON'Ts to protect your HPLC Columns:

- DO use a guard cartridge.
- DO de-gas solvents.
- DO tightly cap column ends.
- DO use purified water and high purity solvents.
- DO use filters.
- DO check the purity of solvents when they arrive in the laboratory.
- DO flush several volumes of methanol (or similar) through the HPLC system prior to shutdown.
- DO flush several milliliters of solvent through new filters, tubing and fittings before connection to the column.
- DO filter both the mobile phase and sample.
- DO store column at room temperature.
- DO protect the column from knocks and bumps.
- DO worry about salt build-up at fitting connections.
- DO attempt to control the temperature of a column.
- DO rinse organic solvents from the column with 50/50 organic/aqueous solvent prior to using buffers.
- DO use PEEK™ ferrules on one piece fingertights where possible.
- DO contact SGE if in doubt.
- DON'T inject crude biological samples directly into a column.
- DON'T let the column dry out.
- DON'T use a pH outside the manufacturer's recommended range for your column.
- DON'T drop your HPLC column.
- DON'T use too much connecting tubing.
- DON'T place excessive back pressure on your column or system.
- DON'T leave a buffer in a column or HPLC system at a zero flow for extended periods of time.
- DON'T use low-grade solvents.
- DON'T encourage growth of microorganisms in aqueous buffers by preparing them days in advance.
- DON'T open the ends of the column – just to see what's inside.
- DON'T use a huge wrench to tighten tiny fittings.
- DON'T use stainless steel ferrules in connections.
- DON'T use high concentrations of aggressive mobile phases.
- DON'T top up mobile phases.



HPLC Column Selection Tree

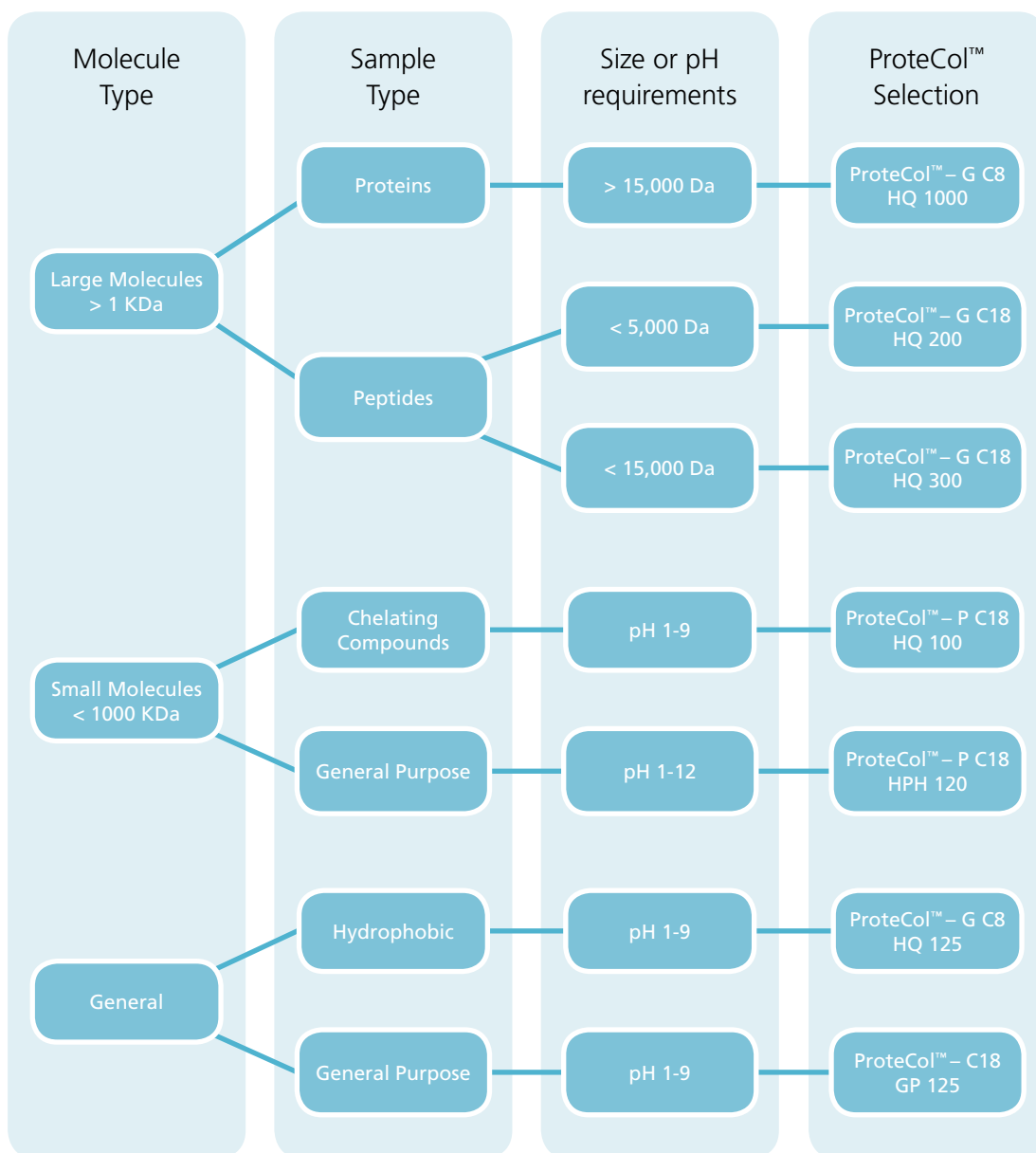

HPLC Columns and Applications

Expert Tips for Large Molecules

Simple DO's and DON'Ts to protect your HPLC Columns:

- DO take all precautions as with the analysis of small molecules (see previous).
- DO use appropriate columns for protein analysis.
- DO use a guard column.
- DO filter/centrifuge samples.
- DO use elevated temperatures and lower flow rates to allow for slower diffusion.
- DO monitor back-pressure and retention behavior to detect protein built-up on the column.
- DO attempt on-column tryptic digest if protein build-up cannot be washed off by traditional means.
- DON'T use conditions that might precipitate proteins - for example high ionic strength.
- DON'T leave column in aqueous buffers.
- DON'T overload columns (large pore size means low capacities).
- DON'T use small pore size stationary phase (restricted diffusion = broad peaks; protein exclusion = virtually no capacity).



ProteCol™ Product Range and Part Numbers

Naming convention: **SGE ProteCol™-P C18 HQ105**

Lining type:
 P = Peek™, G = Glass and GP = General Purpose
Stationary phase

Pore size with particle size
Phase description: HQ = High Quality,
 GP = General Purpose, HPH = High pH

ProteCol™ Analytical HPLC Columns



HPLC Columns and Applications

Expert Tip :

If your reversed phase HPLC run is taking too long on a C18 or ODS column try using a C8 column.



Phase Type	ID	Length (mm)	Pore Size (Å)	Particle Size (µm)	Column Type	Pack Size	Part No.
ProteCol™-G C8 HQ125							
C8 HQ	2.1 mm	150	120	5	Glass Lined Tubing	1	250197
C8 HQ	2.1 mm	250	120	5	Glass Lined Tubing	1	250195
C8 HQ	4.6 mm	150	120	5	Glass Lined Tubing	1	250192
C8 HQ	4.6 mm	250	120	5	Glass Lined Tubing	1	250190
ProteCol™-G HQ1003							
C8 HQ	2.1 mm	100	1000	3	Glass Lined Tubing	1	250172
C8 HQ	2.1 mm	150	1000	3	Glass Lined Tubing	1	250170
ProteCol™ GP125							
C18 GP	2.1 mm	150	120	5	Stainless Steel (PEEK™ frit)	1	250217
C18 GP	2.1 mm	250	120	5	Stainless Steel (PEEK™ frit)	1	250215
C18 GP	4.6 mm	150	120	5	Stainless Steel (PEEK™ frit)	1	250212
C18 GP	4.6 mm	250	120	5	Stainless Steel (PEEK™ frit)	1	250210
ProteCol™-P C18 HPH125							
C18 HPH	2.1 mm	150	120	5	PEEK™ lined	1	250117
C18 HPH	2.1 mm	250	120	5	PEEK™ lined	1	250115
C18 HPH	4.6 mm	150	120	5	PEEK™ lined	1	250112
C18 HPH	4.6 mm	250	120	5	PEEK™ lined	1	250110
ProteCol™-P C18 HQ103 and HQ105							
C18 HQ	2.1 mm	100	100	3	PEEK™ lined	1	250202
C18 HQ	2.1 mm	150	100	3	PEEK™ lined	1	250200
C18 HQ	2.1 mm	150	100	5	PEEK™ lined	1	250107
C18 HQ	2.1 mm	250	100	5	PEEK™ lined	1	250105
C18 HQ	4.6 mm	150	100	5	PEEK™ lined	1	250102
C18 HQ	4.6 mm	250	100	5	PEEK™ lined	1	250100
ProteCol™-G C18 HQ203, HQ303 and HQ305							
C18 HQ	2.1 mm	100	200	3	Glass Lined Tubing	1	250152
C18 HQ	2.1 mm	100	300	3	Glass Lined Tubing	1	250132
C18 HQ	2.1 mm	150	200	3	Glass Lined Tubing	1	250150
C18 HQ	2.1 mm	150	300	3	Glass Lined Tubing	1	250130
C18 HQ	2.1 mm	150	300	5	Glass Lined Tubing	1	250127
C18 HQ	2.1 mm	250	300	5	Glass Lined Tubing	1	250125
C18 HQ	4.6 mm	150	300	5	Glass Lined Tubing	1	250122
C18 HQ	4.6 mm	250	300	5	Glass Lined Tubing	1	250120

For HPLC Connections, see pages 223-225.

Expert Tip:

If you are close to the limit of detection using a standard 4.6 mm ID HPLC column try using a 2.1 mm ID column. This saves solvent too.



ProteCol™ Capillary HPLC Columns



Phase Type	ID	Length (mm)	Pore Size (Å)	Particle Size (µm)	Column Type	Tail ID (µm)	Tail OD	Pack Size	Part No.
ProteCol™ C8 HQ1003									
C8 HQ	150 µm	100	1000	3	PEEKsil™	50	1/32"	1	250182
C8 HQ	150 µm	150	1000	3	PEEKsil™	50	1/32"	1	250180
C8 HQ	300 µm	100	1000	3	PEEKsil™	50	1/32"	1	250177
C8 HQ	300 µm	150	1000	3	PEEKsil™	50	1/32"	1	250175
ProteCol™ C18 HQ203 and HQ303									
C18 HQ	150 µm	100	200	3	PEEKsil™	50	1/32"	1	250162
C18 HQ	150 µm	100	300	3	PEEKsil™	50	1/32"	1	250142
C18 HQ	150 µm	150	200	3	PEEKsil™	50	1/32"	1	250160
C18 HQ	150 µm	150	300	3	PEEKsil™	50	1/32"	1	250140
C18 HQ	300 µm	100	200	3	PEEKsil™	50	1/32"	1	250157
C18 HQ	300 µm	100	300	3	PEEKsil™	50	1/32"	1	250137
C18 HQ	300 µm	150	200	3	PEEKsil™	50	1/32"	1	250155
C18 HQ	300 µm	150	300	3	PEEKsil™	50	1/32"	1	250135

HPLC Columns and Applications

ProteCol™ HPLC Capillary Trap Columns



Phase Type	ID (µm)	Length (mm)	Pore Size (Å)	Particle Size (µm)	Tail ID (µm)	Tail OD	Pack Size	Part No.
C8	150	10	300	3	50	1/32"	1	2224058
C8	300	5	300	3	50	1/32"	1	2222158
C18	150	10	300	3	50	1/32"	1	2224054
C18	300	5	300	3	50	1/32"	1	2227054
C18	300	10	300	3	50	1/32"	1	2222054

ReproSil™ HPLC Capillary Trap Columns

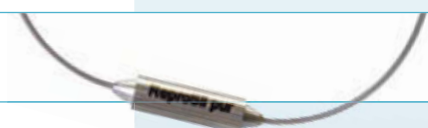

ReproSil™ is the reference material for leading proteomics scientists. ReproSil™ captures the broadest range of peptides from hydrophilic to hydrophobic.

Phase Type	ID (µm)	Length (mm)	Pore Size (Å)	Particle Size (µm)	Tail ID (µm)	Tail OD	Pack Size	Part No.
C18-AQ	150	10	120	5	50	1/32"	3	2224072
C18-AQ	300	10	120	3	50	1/32"	3	2222066
C18-AQ	300	10	120	5	50	1/32"	3	2222072
ODS-3	300	10	120	5	50	1/32"	3	2222070



ProteCol™ HPLC Guard Columns



Phase Type	ID	Length (mm)	Pore Size (Å)	Particle Size (µm)	Column Type	Pack Size	Part No.
ProteCol™ C18 HQ105							
C18 HQ	2.1 mm	10	100	5	Stainless Steel (PEEK™ frit)	3	250007
C18 HQ	4 mm	10	100	5	Stainless Steel (PEEK™ frit)	3	250009
ProteCol™ C8 HQ125							
C8 HQ	2.1 mm	10	120	5	Stainless Steel (PEEK™ frit)	3	250003
C8 HQ	4 mm	10	120	5	Stainless Steel (PEEK™ frit)	3	250005
ProteCol™ C18 HPH125							
C18 HPH	2.1 mm	10	120	5	Stainless Steel (PEEK™ frit)	3	250013
C18 HPH	4 mm	10	120	5	Stainless Steel (PEEK™ frit)	3	250015
ProteCol™ C18 HQ203 and HQ303							
C18 HQ	2.1 mm	10	200	3	Stainless Steel (PEEK™ frit)	3	250021
C18 HQ	2.1 mm	10	300	3	Stainless Steel (PEEK™ frit)	3	250029
C18 HQ	2.1 mm	10	300	5	Stainless Steel (PEEK™ frit)	3	250025
C18 HQ	4 mm	10	200	3	Stainless Steel (PEEK™ frit)	3	250023
C18 HQ	4 mm	10	300	3	Stainless Steel (PEEK™ frit)	3	250031
C18 HQ	4 mm	10	300	5	Stainless Steel (PEEK™ frit)	3	250027
ProteCol™ C8 HQ1003							
C8 HQ	2.1 mm	10	1000	3	Stainless Steel (PEEK™ frit)	3	250019
C8 HQ	4 mm	10	1000	3	Stainless Steel (PEEK™ frit)	3	250017
ProteCol™ C18 GP125							
C18 GP	4 mm	10	120	5	Stainless Steel (PEEK™ frit)	3	250033

HPLC Columns and Applications

ProteCol™ HPLC Capillary Guard Columns



Phase Type	ID (µm)	Length (mm)	Pore Size (Å)	Particle Size (µm)	Tail ID (µm)	Tail OD	Pack Size	Part No.
C8	300	10	300	3	50	1/32"	3	222205
C18	150	10	300	3	50	1/32"	3	222404
C18	300	10	300	3	50	1/32"	3	222204

For your inert HPLC connection tubing solutions use PEEKsil™, see pages 234-237.

PAHs using EPA 610 on ProteCol™ C18 GP125

Column Part No.:	250212	Gradient:	0 min 70% B
Sample:	Polyaromatic Hydrocarbons (EPA610 mix)		20 min 100% B
Column:	ProteCol™ C18 GP125 150 x 4.6 mm		50 min 100% B
Injection Volume:	1 µL		51 min 70% B
Mobile Phase A:	Water	Flow rate.:	1.0 ml/min
Mobile Phase B:	100% Acetonitrile	Temperature:	20 °C
		Detection:	254 nm

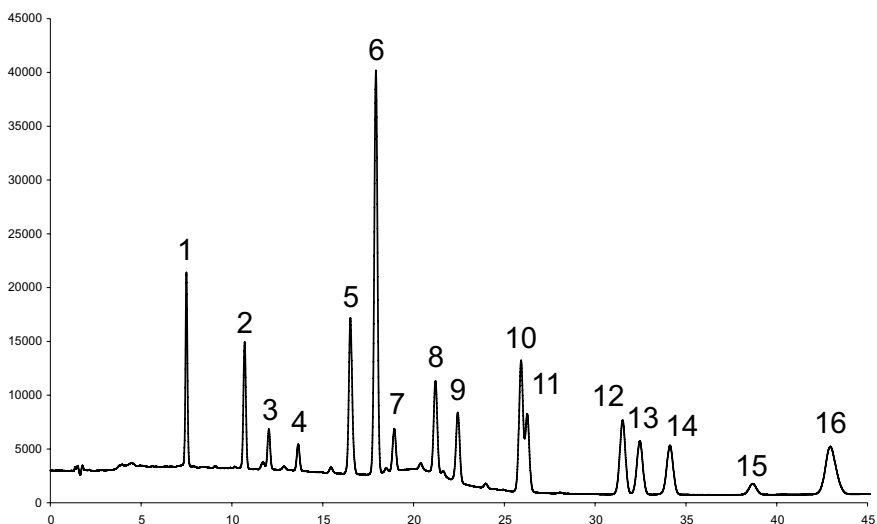

Components

1. Naphthalene
2. Acenaphthylene
3. Acenaphthene
4. Fluorene
5. Phenanthrene
6. Anthracene
7. Fluoranthene
8. Pyrene
9. Benzo[a] Anthracene
10. Chrysene
11. Benzo[b] Fluoranthene
12. Benzo[k] Fluoranthene
13. Benzo[a] Pyrene
14. Dibenz[a,h] Anthracene
15. Benzo[g,h,i] Perylene
16. Indeno[1,2,3-cd] Pyrene



HPLC Columns and Applications

HPLC Application by Industry | General Chemistry

Paraben Mixture on ProteCol™ -P C18 HPH125

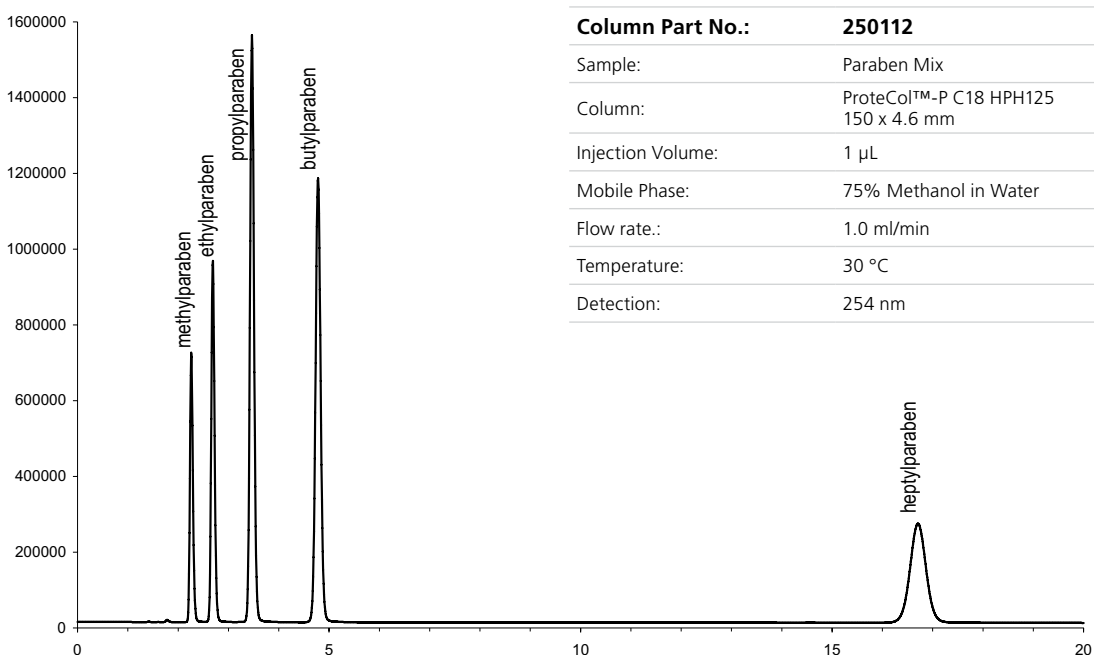



TP-0199-H | Measuring Fruit Juice Adulteration by Changes in Flavonoid Content Using MEPS™ on ProteCol™ HQ105

Column Part No.:	250102	Gradient Profile:	0 min - 0 % B
Column:	ProteCol™ HQ105 150 mm x 4.6 mm ID		20 min - 50 % B
Mobile Phase A:	0.1 % TFA in water		30 min - 100 % B
Mobile Phase B:	0.1 % TFA in 80 % methanol		40 min - 100 % B
LC System:	Shimadzu Prominance LC20.		41 min - 0 % B
Flow Rate:	1.0 ml/min		60 min - 0 % B
		Column Temperature:	40 °C
		Detection:	254, 350 and 550 nm

HPLC Columns and Applications

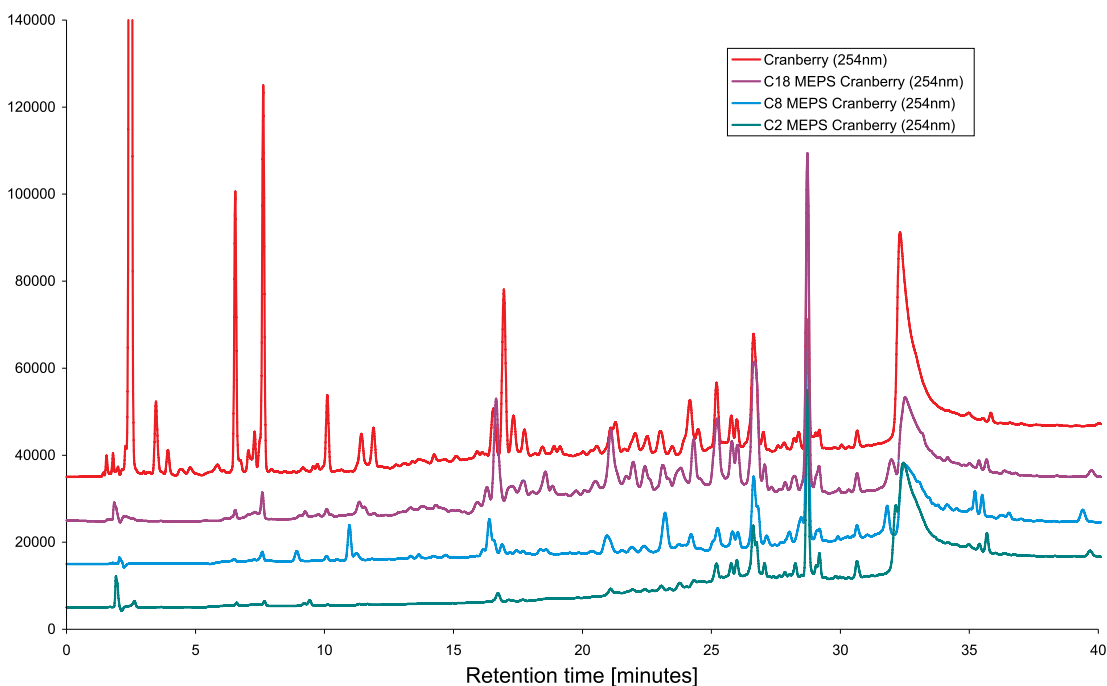

Chromatograms of cranberry juice prepared with different MEPS™ phases.

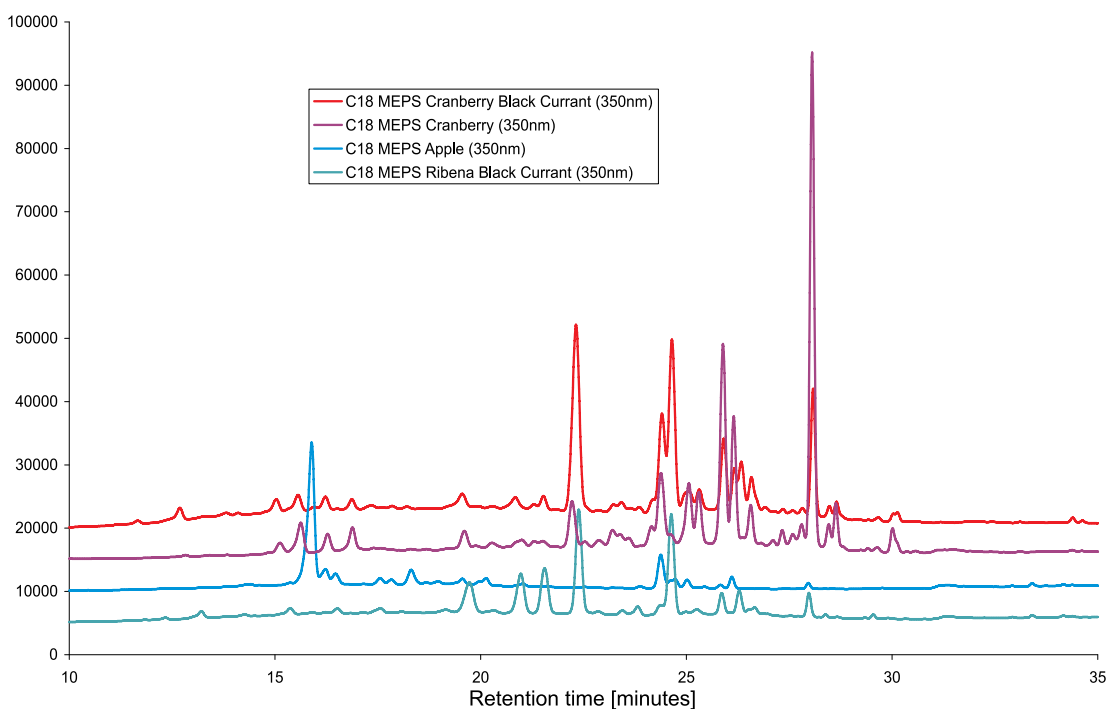

Flavonoid fingerprinting of various fruit juices on MEPS™ C18.

Enolase Trypsin Digest on ProteCol™ Trap Column C18 HQ303

Column Part No.:	250140	Gradient:	0 min 10% B
Sample:	Enolase Trypsin Digest 10 fmol/ μ L		40 min 40% B
Column:	ProteCol™ C18 HQ303 150 mm x 150 μ m ID		45 min 100% B
Injection Volume:	8 μ L		59 min 100% B
Mobile Phase A:	0.1% Formic Acid in Water		60 min 5% B
Mobile Phase B:	0.1% Formic Acid in 90% Acetonitrile		70 min 5% B
		Flow rate.:	0.5 μ L/min
		Detection:	QSTAR Elite MS with nanoLC source

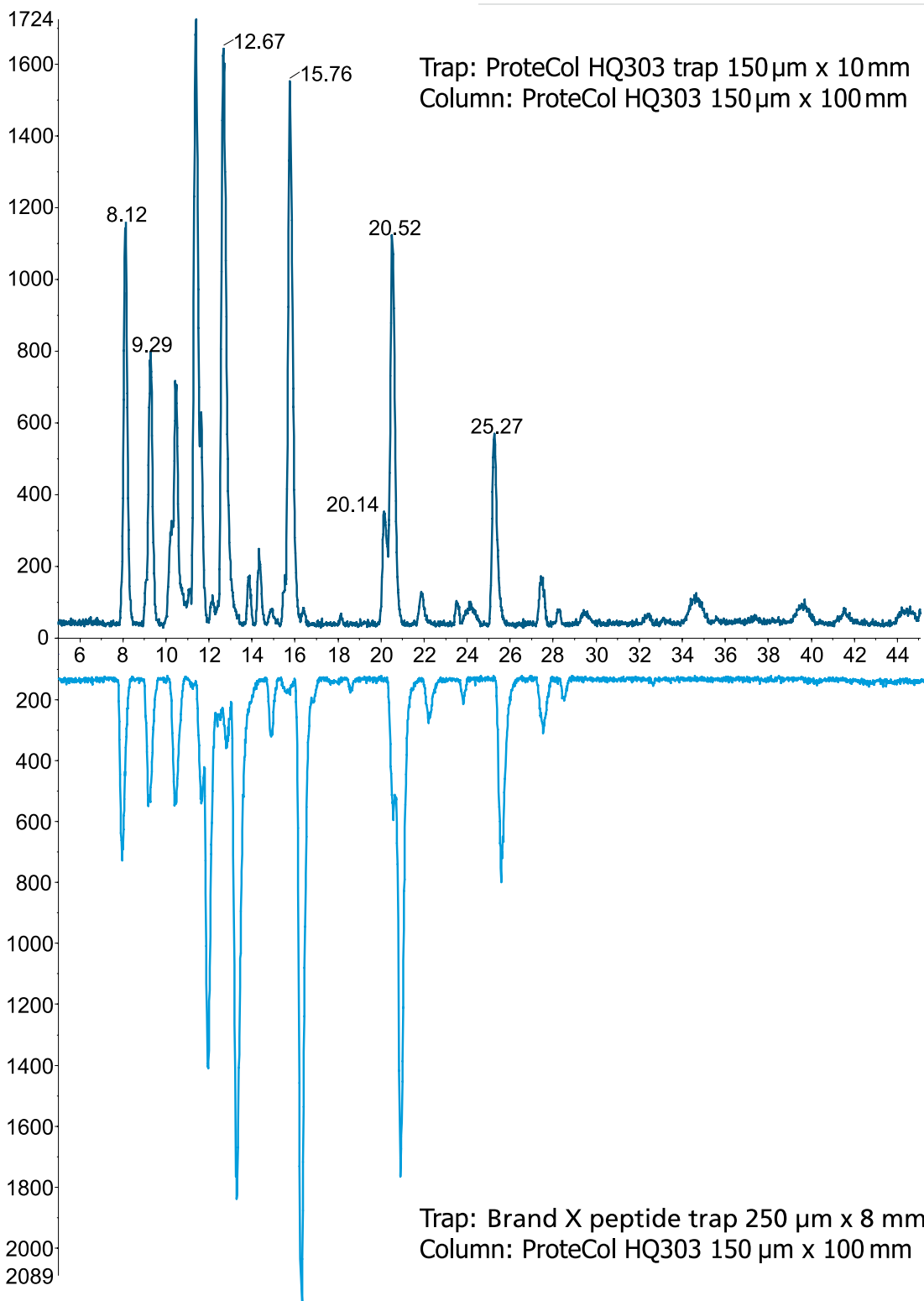

HPLC Columns and Applications





TA-0141-H | Ribosomal Proteins on ProteCol™ C8 HQ 1003

Column Part No.:	250170
Sample:	Ribosomal Proteins from Rat Liver
Column:	ProteCol™ C8 HQ 1003 150 mm x 2 mm ID
Injection Volume:	10 µL
Solvent A:	Aqueous 0.1% (v/v) Formic Acid
Solvent B:	Acetonitrile/0.1% (v/v) Formic Acid
LC:	Agilent 1100 LC System

Gradient:	0 min 5% B
	80 min 45% B
	81 min 85% B
	82 min 85% B
	83 min 5% B
	88 min 5% B
Flow rate.:	0.25 mL/min
Detection:	Agilent 6220 ESI-TOF LC/MS

HPLC Columns and Applications

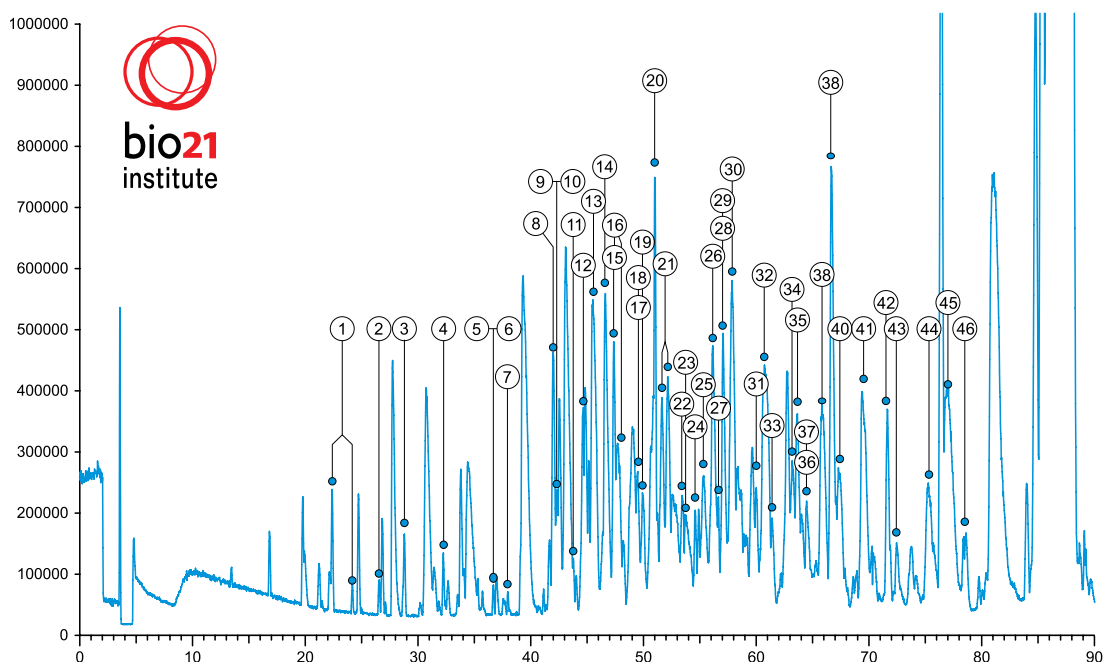

No.	RT [min]	Mass	Protein	No.	RT [min]	Mass	Protein
1	22.4	10943	L37	23	53.9	28680	S6
1	24.2	10943	L37	24	54.5	23191 23647	L14 (native & with mod)
2	26.5	6648	S30	25	55.3	23345	L13a
3	28.7	6276	L39	26	55.3	16503	L27a
4	31.9	12321	L36a(L44)	27	56.2	24015	L15
5	36.7	17279	L26	28	56.7	9170	S21, N-acetylmethionine
6	36.7	9399	S27a	29	56.7	14776	L23 N-acetylserine
7	37.9	9270	S27a; cleaved C-term.	30	57.8	15954	S19
8	42	18449	L21 NG to KR	31	60	13284	S20
9	42.3	17623 17779	L24 & L24 cleaved C-term.	32	60.8	21527	L18
10	42.3	18448	L21	33	61.4	29464	S4
11	43.8	15667	L27	34	63.2	29862	L7a
12	44.6	12122	L36	35	63.2	16314	S16
13	45.6	15644	L28	35	63.6	16314	S16
14	46.6	8087	L38	36	64.5	29466	S4
15	47.3	12465	L35a	37	64.5	15379	S17
16	47.3	23922	L13 (terminal KK)	38	65.8	17091	S13
16	47.7	23922	L13 (terminal KK)	39	66.8	17629	S18 N-acetylserine
17	49.1	27908	L8	40	67.4	22169	S7 N-acetylmethionine
17	49.5	27908	L8	41	69.5	22460	S9
18	49.5	14164	L31	42	71.6	14708	S15a
19	50	18343	S11	43	72.5	21893	L9
20	51	14421	L35	44	75.3	11772	P2
21	51.6	15465	S24	45	77	30355	L7
21	52.2	15466	S24	46	78.5	26585	S3 N-acetylanine
22	53.4	15727	L32				

BPI/EIC Chromatograms of BSA Tryptic Peptides on ProteCol™ C18 HQ303

Column Part No.:	250137	Gradient:	0 min 0% B (loading)
Sample:	BSA Tryptic Digest		8 min 50% B
Column:	ProteCol™ C18 HQ303 100 x 0.3 mm		26 min 80% B
LC:	Dionex Ultimate 3000		27 min 80% B
Solvent A:	0.1% Formic Acid		37 min 80% B
Solvent B:	0.1% Formic Acid in Acetonitrile		38 min 0% B
			45 min 0% B
		Detection:	Bruker HCT ion trap
		Mascot Search via Biotools:	Mascot Score: 1481
			71.5
		Sequence coverage:	2 pmol of sample injected, (130 ng)

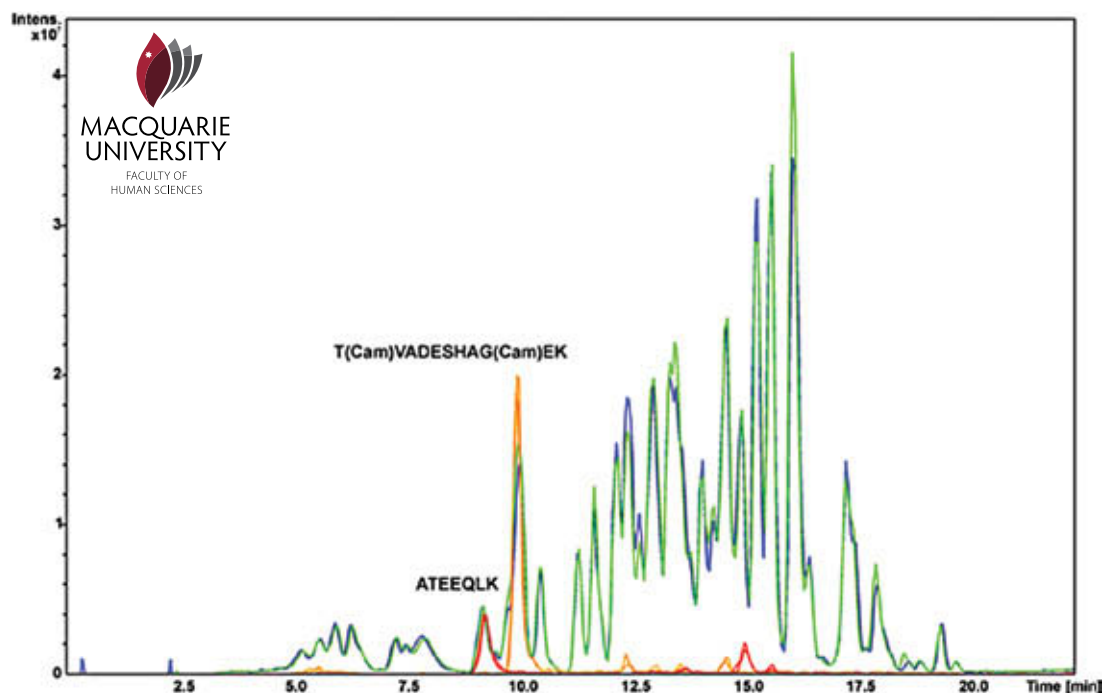

Two hydrophilic marker peptides usually not reproducibly detected on different column materials are reproducibly retained and detected using ProteCol™ C18 HQ303 column. Green and blue: Overlaid BPI chromatograms of 2 consecutive runs of 2 pmol of BSA (~130 ng) red and orange: extracted ion chromatograms (EIC) of the two respective peptides.



HPLC Columns and Applications





BPI/EIC Chromatograms of Human α 1-proteinase Inhibitor Tryptic Peptides on ProteCol™ C18 HQ303

Column Part No.:	250137	27 min 80% B
Sample:	Tryptic Digest of Human α 1-proteinase Inhibitor	37 min 80% B
Column:	ProteCol™ C18 HQ303 100 x 0.3 mm	38 min 0% B
LC:	Dionex Ultimate 3000	45 min 0% B
Solvent A:	0.1% Formic Acid	Detection:
Solvent B:	0.1% Formic Acid in Acetonitrile	Mascot Search via Biotoools:
Gradient:	0 min 0% B (loading)	Mascot Score: 1481
	8 min 50% B	Sequence coverage:
	26 min 80% B	64.9% (does not include the glycopeptides that comprise 21% of the sequence). 10 pmol of sample injected, (500 ng)

HPLC Columns and Applications

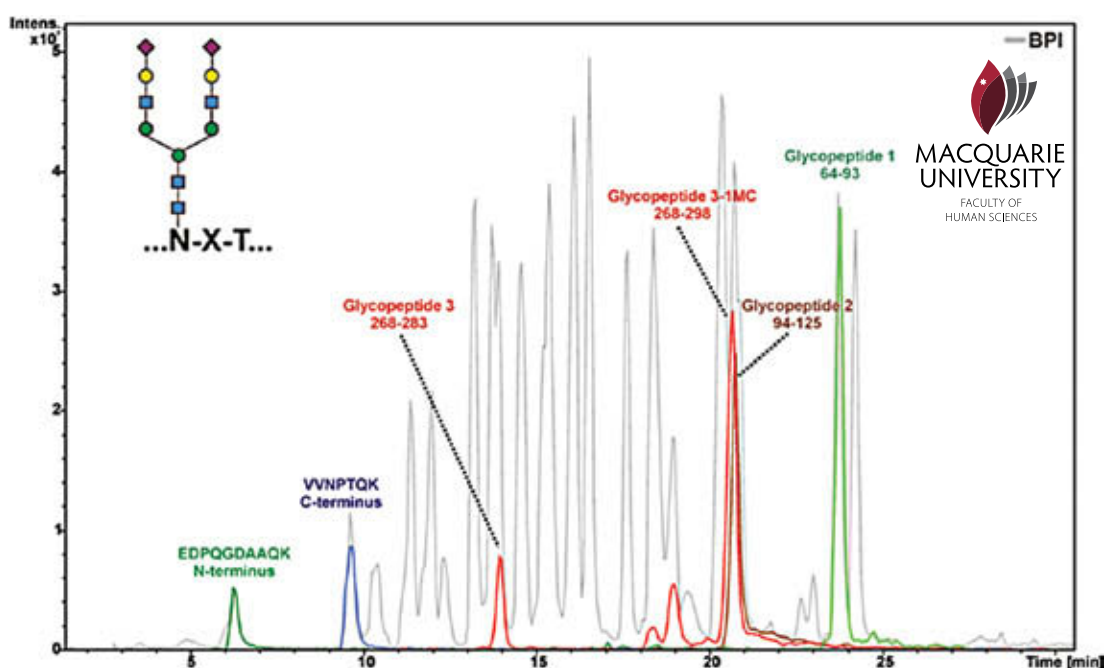

Tryptic peptides reflecting the protein termini are detected as well separated peaks, though the N-terminal peptide is isocratically separated under loading conditions. The different glycopeptides carrying mainly disialylated, biantennary N-glycans as described previously are well separated. Grey: BPI of A1PI tryptic peptides, other colors: Extracted ion chromatograms (EIC) of the respective peptides as indicated.

TP-0190-H | NIST SRM 870 on ProteCol™ C18 HQ105

Column Part No.:	250100	Injection Volume:	1 µL
Sample:	Uracil (28 µg/g), Toluene (1400 µg/g), Ethylbenzene (1700 µg/g), Quinizarin (94 µg/g), Amitriptyline (2800 µg/g) in methanol	Mobile Phase:	4 mM phosphate pH7.0 in 80 % methanol
Column:	ProteCol™-P C18 HQ105 250 mm x 4.6 mm ID	Flow rate.:	1.0 ml/min
		Temperature:	23 °C
		Detection:	254 nm
		LC System	Shimadzu Prominence 20 AC

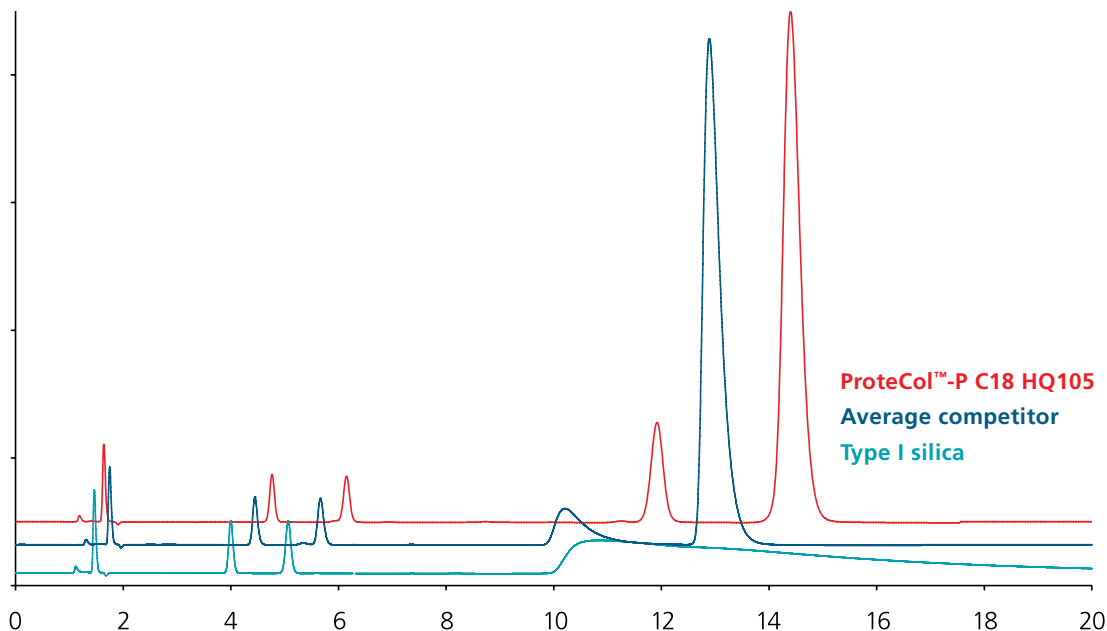

This figure shows the chromatogram achieved under the described conditions in comparison with a competitor's column and a column packed with type I silica.



HPLC Columns and Applications

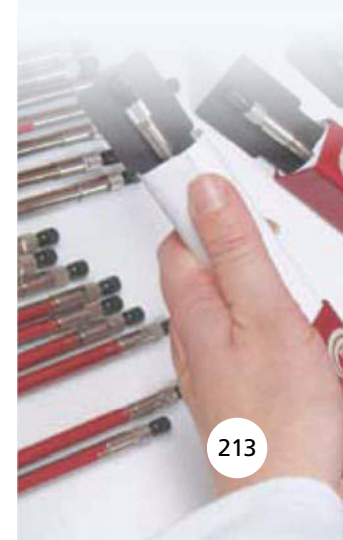



TA-0135-M | The Extraction and Analysis of Urinary Antitussive Metabolites using MEPS™ and ESI-LCMSⁿ on ProteCol™-P C18 HQ105

Abstract

Urine specimens were first hydrolysed with beta-glucuronidase and then the analytes of interest were extracted using MEPS™ prior to analysis on a ProteCol™-P C18 HQ105 column using a 1 % v/v aqueous acetic acid – methanol mobile phase. Detection of the target analytes was by ESI-MSMS with collision parameters selected for specific analytes. The MEPS™ phases were nominally 50 µm silicas modified with C18, C8 or SCX chemistries. Speculative structural elucidation of metabolites was possible by mass fragmentography and MS3 or MS4 as required.

Experimental

Administration and Sample Collection

Oral administration of a single dose of: 10 mL Vicks® Cough Syrup (equivalent to pentoxyverine (carbetapentane) citrate 15 mg), 10 mL Robitussin® DX Dry Cough Forte syrup (equivalent to 30 mg dextromethorphan hydrobromide) 2 x Mersyndol® day strength tablets (equivalent to paracetamol 1000 mg and codeine phosphate 19.2 mg). Naturally voided urine samples were collected at 0, 2, 3 and 4 hours following administration. Urine samples were stored frozen at -20 °C until required for analysis.

Sample preparations

3 mL aliquots of urine from the samples collected at 0 and 2 hours after oral administration were diluted with 0.1 M phosphate buffer (pH 6.0, 4.5 mL) and the pH adjusted to 6.2-6.3. The samples were then enzyme hydrolyzed with beta-glucuronidase for 2 hours at 50 °C. Samples were extracted by either a conventional mixed mode SPE method or by a reversed-phase MEPS™ method.

SPE extraction was performed on Bond-Elut Certify™ columns using methods described previously. (Wynne PM, Batty DC, Vine JH and Simpson NKJ., *Chromatographia*, 59 (4/5), S50-S61, (2004)).

MEPS™ extraction was performed on C18 MEPS™ BINS fitted to a 100 µL MEPS™ syringe. MEPS™ BINS were conditioned sequentially with 50 µL methanol and 100 µL water.

- 50 µL methanol conditioning.
- 100 µL water conditioning.
- 1 mL sample was drawn and expelled in 80 µL steps.
- 80 µL water wash.
- 50 µL sodium tetraborate pH adjustment.
- 80 µL water wash.
- 2 x 80 µL air drying.
- 2 x 20 µL methanol elution.
- 10 µL iso-propanol elution.

Column Part No.:	250102
Column:	ProteCol™-P C18 HQ105 150 mm x 4.6 mm ID
Injection Volume:	10 µL
Mobile Phase A:	1 % aq. acetic acid in 10 % methanol
Mobile Phase B:	1 % aq. acetic acid in 90 % methanol
Flow rate.:	0.7 ml/min
Gradient:	20 min 0 to 100 % B 10 min at 100 % B
Temperature:	40 °C
Detection:	Thermo LCQ Classic positive ion mode

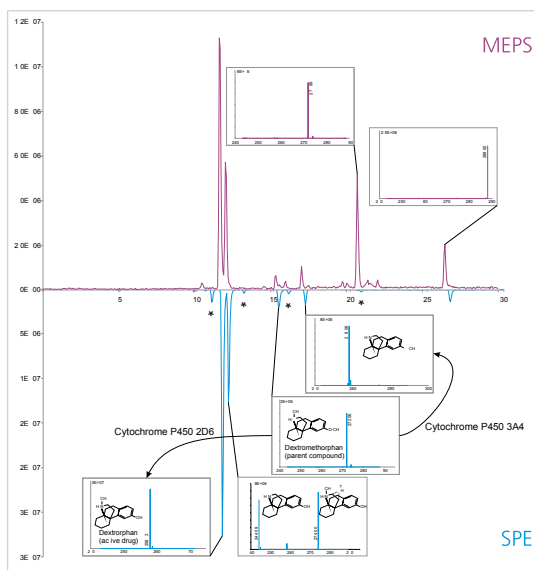

Metabolites of Dextromethorphan

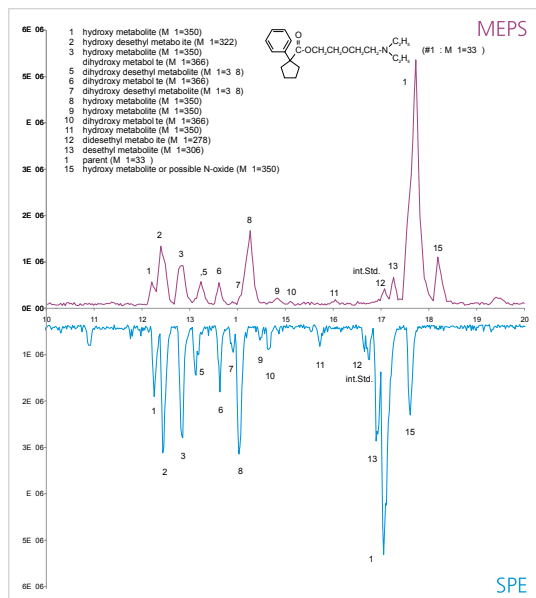

Metabolites of Carbetapentane

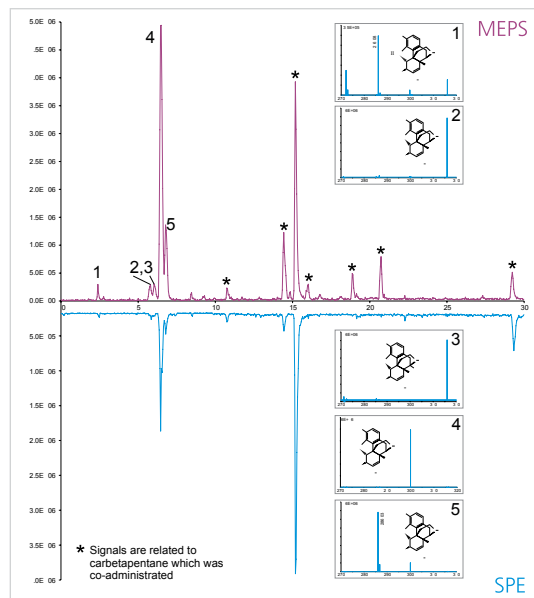

Metabolites of Codeine



HPLC Columns and Applications

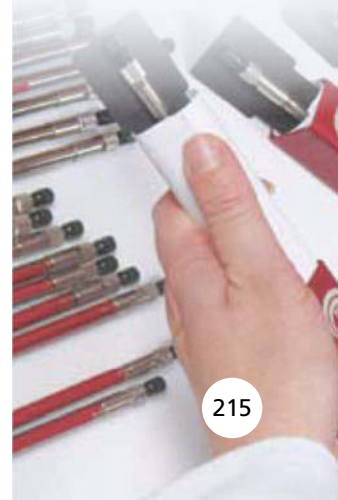



HPLC Supplies and Accessories

MEPS™ Micro SPE	218-221
ProteCol™ In-Line Filters	222
In-line Filter	222
PEEKsil™ Tubing Kits	222
PEEKsil™ Injection Loop	223
EasyLok™ Fittings	223
Hexnut™ Fittings	223
HPLC Column Replacement Frits	224
ProteCol™ Unions, Ferrules and Fittings	224-225
High Efficiency HPLC Column Couplers	225
Detector/Tubing Unions	225
Guard Cartridge Systems	226
Solvent Filter	227
SilFlow™ - New Splitter Technology	227

MEPS™ (Micro Extraction by Packed Sorbent) has been created by SGE to overcome the limitations of conventional sample preparation methods. It has been estimated that up to 75% of labor time in a typical analytical laboratory workflow is consumed in preparing and processing

samples prior to their analysis. Therefore, any improvement in sample preparation efficiency will increase sample throughput and deliver important time savings for busy laboratories. Below is a comparison of MEPS™ with other common sample preparation techniques.

Comparison of Sample Preparation Methods

	LLE (Liquid-Liquid Extraction)	SPE (Solid Phase Extraction)	MEPS™ (Micro Extraction by Packed Sorbent)
Method Description	<ul style="list-style-type: none"> Relies on the difference in solubility of analytes in immiscible liquids. One phase is aqueous (hydrophilic) and the other is an organic (hydrophobic) solvent. 	<ul style="list-style-type: none"> The organic phase is immobilized on a stationary phase in a cartridge. A suitable organic solvent mixture is used to selectively elute the compounds of interest. Stationary phase does not move, sample and solvents must be moved to the cartridge. Can be used to remove unwanted interfering compounds and to increase sample concentration. 	<ul style="list-style-type: none"> A miniaturized form of SPE with a reduced stationary phase (3mg) integrated into a high quality SGE analytical syringe. Stationary phase moves with the syringe which aspirates and dispenses the sample. Can be used to remove unwanted interfering compounds.
Sample Volume Required	<ul style="list-style-type: none"> Generally large e.g. 10-100 mL. 	<ul style="list-style-type: none"> Small e.g. 3 mL 	<ul style="list-style-type: none"> Micro e.g. 50 µL.
Evaporation Step	<ul style="list-style-type: none"> Solvent evaporation required to increase sample concentration to a level that can be analyzed. 	<ul style="list-style-type: none"> In the majority of cases, solvent evaporation required to increase sample concentration to a level that can be analyzed. 	<ul style="list-style-type: none"> Evaporation generally not required.
Solvent Used	<ul style="list-style-type: none"> Large solvent volumes required e.g. 10-100 mL. 	<ul style="list-style-type: none"> Large solvent volumes required e.g. 10 mL. 	<ul style="list-style-type: none"> Micro e.g. 500 µL.
Time	<ul style="list-style-type: none"> Slow and labor intensive. 	<ul style="list-style-type: none"> Evaporation step can be time consuming. 	<ul style="list-style-type: none"> Fast e.g. minutes, as one step washes, loads and elutes.
Automation	<ul style="list-style-type: none"> Entire process cannot be automated. 	<ul style="list-style-type: none"> Can be automated. 	<ul style="list-style-type: none"> Can be fully automated.
Price	<ul style="list-style-type: none"> High solvent purchase and discard costs. 	<ul style="list-style-type: none"> High solvent purchase and discard costs. 	<ul style="list-style-type: none"> Low solvent purchase and discard costs.

MEPS™ (Micro Extraction by Packed Sorbent) is a micro SPE solution that incorporates the stationary phase in a micro-cartridge integrated in a high quality SGE analytical syringe (Barrel Insert and Needle - BIN configuration). MEPS™ is the miniaturization of conventional SPE packed bed devices from mL to µL bed volumes.

MEPS™ stationary phases available: C2, C8, C18, Silica, C8+SCX, SAX.

eVol® MEPS™ stationary phases available: C2, C8, C18, APS, DVB, SDVB

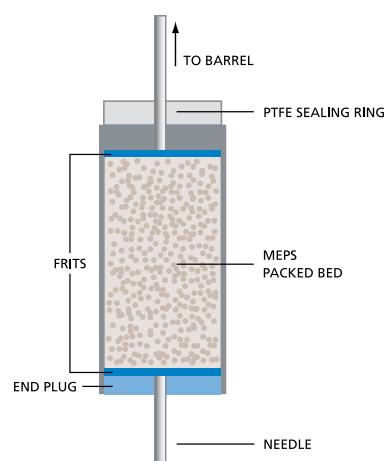

Schematic of the MEPS™ stationary phase within the syringe needle – SGE's patented 'Barrel Insert and Needle' (BIN) configuration.

HPLC Supplies and Accessories

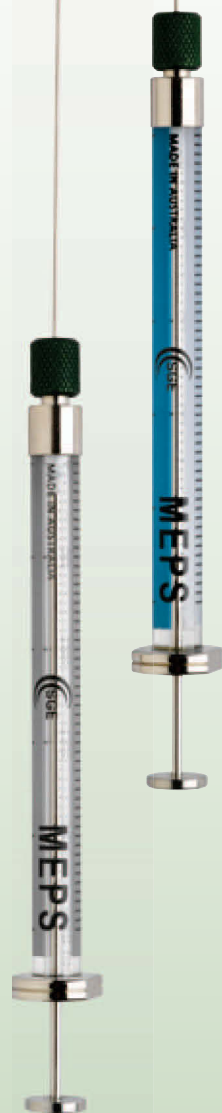

How To Use MEPS™

- Step 1: Pump the sample through the MEPS™ BIN (one or more volumes may be taken).
- Step 2: Wash the MEPS™ BIN once by pumping 20 µL to 50 µL of wash solution through the BIN to remove interferences.
- Step 3: Elute the analyte by drawing solvent through the BIN into the syringe barrel.
- Step 4: Inject the analyte directly into the injector.
- Pump 50 µL solvent followed by 50 µL wash solution to prepare BIN for the next sample.

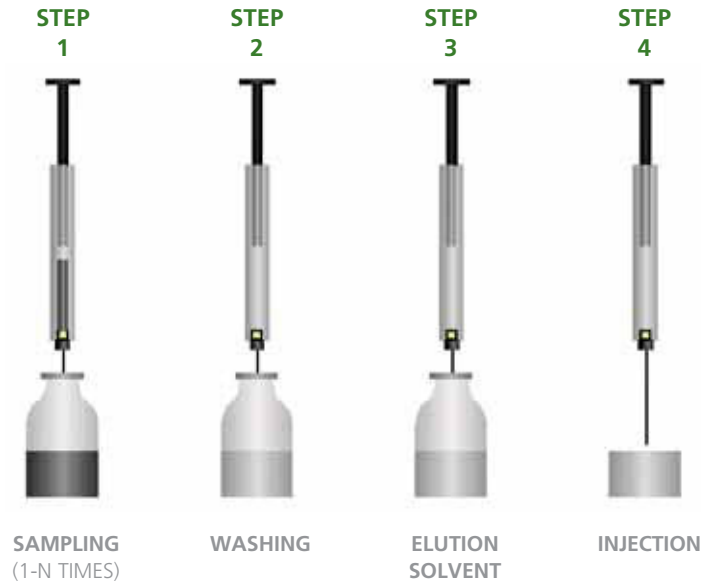

HPLC Supplies and Accessories

MEPS™ Is Reusable

Like conventional SPE, the number of times the cartridge can be reused is dependent on the sample matrix and the cleaning regime between elutions. Since only 3mg of stationary phase is used in MEPS™ it can be

washed effectively between each extraction without the need for large solvent volumes. For simple applications, MEPS™ devices have been used successfully for up to 50 cycles making it very cost effective.

MEPS™ Can Be Semi or Fully Automated

Semi-automation of MEPS™ can be achieved by coupling MEPS™ syringes to SGE's eVol® automated analytical syringe to speed up repetitive SPE and is ideal for rapid method development. For more information on eVol® see pages 22-24.

MEPS™ can also be fully automated on autosamplers such as the CTC PAL for on-line SPE and injection.

















MEPS™ Has Proven Accuracy and Precision Compared to Other Sample Preparation Methods

Method	Ropivacaine LOD (nM)	Accuracy (%)	Precision (RSD%) (Inter-assay)	Handling Time
MEPS™ / GC-MS	2	105	5.0	1 min
LLE / GC-MS	2	101	3.8	20 min
SPE / LC-UV	100	101	3.0	20 min
SPME / GC-MS	5	110	6.3	40 min

Comparison of accuracy and precision between MEPS™ and other methods for ropivacaine (local anesthetics).

MEPS™ Applications and Publications

MEPS™ micro SPE format is ideally suited to previously challenging applications. For an example of MEPS™ used in a forensic application see page 12.

Industry	Title	Author	Journal
Environmental 	Determination of organic priority pollutants and emerging compounds in wastewater and snow samples using multiresidue protocols on the basis of microextraction by packed sorbents coupled to large volume injection gas chromatography-mass spectrometry analysis.	Prieto et al	J Chrom A, 2010, 1217: 6002-6011
Forensic and Pharmaceutical  	Liquid chromatographic analysis of oxcarbazepine and its metabolites in plasma and saliva after a novel microextraction by packed sorbent procedure.	Saracino et al	Anal Chim Acta, 2010, 661: 222-228
Environmental 	At-line microextraction by packed sorbent-gas chromatography-mass spectrometry for the determination of UV filter and polycyclic musk compounds in water samples.	Moeder et al	JChrom A, 2010, 1217:2925-2932
Forensic 	Contribution of microextraction in packed sorbent for the analysis of cotinine in human urine by GC-MS.	Lafay et al	Anal Bioanal Chem, 2010, 396: 937-941
General Chemistry and Life Science  	Recent advances in microextraction by packed sorbent for bioanalysis.	Abdel-Rehim	J Chrom A, 2010, 1217: 2569-2580
Forensic 	Rapid identification and quantification of methamphetamine and amphetamine in hair by gas chromatography/mass spectrometry coupled with micropulverized extraction, aqueous acetylation and microextraction by packed sorbent.	Miyaguchi et al	J. Chrom A, 2009, 1216: 4063-4070
General Chemistry and Life Science  	Fully Automatic Sample Treatment by Integration of Microextraction by Packed Sorbents into Commercial Capillary Electrophoresis-Mass Spectrometry Equipment: Application to the Determination of Fluoroquinolones in Urine.	Morales-Cid et al	Anal. Chem., 2009, 81: 3188-3193
Forensic 	Screening of Cocaine and Its Metabolites in Human Urine Samples by Direct Analysis in Real-Time Source Coupled to Time-of-Flight Mass Spectrometry After Online Preconcentration Utilizing Microextraction by Packed Sorbent.	Jagerdeo E, Abdel-Rehim M	J Am Soc Mass Spectrom. 2009 May;20(5):891-899
Food and Flavour 	Determination of 2,4,6-Trichloroanisole and 2,4,6-Tribromoanisole in Wine using Microextraction in Packed Syringe and Gas Chromatography-Mass Spectrometry.	Jönsson et al	J. Agric. Food Chem., 2008, 56: 4962-4967
General Chemistry 	Study of the factors affecting the performance of microextraction by packed sorbent (MEPS) using liquid scintillation counter and liquid chromatography-tandem mass spectrometry.	Altun and Abdel-Rehim	Anal Chim Acta. 2008, 630:116-123
Pharmaceutical 	MEPS™ as a rapid sample preparation method to handle unstable compounds in a complex matrix: determination of AZD3409 in plasma samples utilizing MEPS™-LC-MS-MS.	Abdel-Rehim M et al	J Chromatogr Sci. 2008 46:518-523
Pharmaceutical and Life Science  	Rapid and Sensitive Method for Determination of Cyclophosphamide in Patients Plasma Samples Utilizing Microextraction by Packed Sorbent Online with Liquid Chromatography-Tandem Mass Spectrometry (MEPS™-LC-MS/MS).	Said et al	J. Liquid Chromatography & Related Technologies 2008, 31: 683-694

MEPS™ Syringe Options

All syringes may be used manually as well as with the listed autosamplers.

Description	# per Pack	Part No.
100 µL Removable needle MEPS™ syringe for CTC Analytics, HTA 300A Plus & Varian 8400 systems.	1	005291
Replacement plunger assembly for 005291.	1	031826
250 µL Removable needle MEPS™ syringe for CTC Analytics, HTA 300A Plus & Varian 8400 systems.	1	006291
Replacement plunger assembly for 006291.	1	031831
250 µL Removable needle MEPS™ syringe for CTC Analytics systems.	1	006292
Replacement plunger assembly for 006292.	1	031831
100 µL Removable needle MEPS™ syringe for Agilent systems.	1	005292
Replacement plunger assembly for 005292.	1	0318263
250 µL Removable needle MEPS™ syringe for Agilent systems.	1	006293
Replacement plunger assembly for 006293.	1	0318303
100 µL removable needle MEPS™ XCHANGE® syringe for CTC PAL-xt	1	2928500
250 µL removable needle MEPS™ XCHANGE® syringe for CTC PAL-xt	1	2928600

For eVol® MEPS™ syringes please see page 24.

MEPS™ Barrel Insert and Needle (BIN) Assembly Options

For GC applications, needle is 23 gauge, 0.63 mm OD, Cone point style.

Description	For Use with MEPS™ Syringe P/N	# per Pack	Part No.
MEPS™ BIN for CTC Analytics, HTA 300A Plus & Varian 8400 systems			
C18	005291 and 006291	5	2900101
Silica	005291 and 006291	5	2900102
C8+SCX*	005291 and 006291	5	2900103
C2	005291 and 006291	5	2900104
C8	005291 and 006291	5	2900106
MEPS™ Development kit (contains 1 each of C18, C8, C2, SILICA and C8+SCX)	005291 and 006291	1	2900105
MEPS™ BIN for CTC Analytics systems using 250 µL syringes			
C18	006292	5	2900301
Silica	006292	5	2900302
C8+SCX*	006292	5	2900303
C2	006292	5	2900304
C8	006292	5	2900306
MEPS™ Development kit (contains 1 each of C18, C8, C2, SILICA and C8+SCX)	006292	1	2900305
MEPS™ BIN for Agilent systems 7693A			
C18	005292 and 006293	5	2900601
Silica	005292 and 006293	5	2900602
C8+SCX*	005292 and 006293	5	2900603
C2	005292 and 006293	5	2900604
C8	005292 and 006293	5	2900606
MEPS™ Development kit (contains 1 each of C18, C8, C2, SILICA and C8+SCX)	005292 and 006293	1	2900605

For LC Applications, needle is 22 gauge, 0.72 mm OD.

Description	For Use with MEPS™ Syringe P/N	# per Pack	Part No.
MEPS™ BIN for CTC Analytics, HTA 300A Plus & Varian 8400 systems			
C18	005291 and 006291	5	2900401
Silica	005291 and 006291	5	2900402
C8+SCX*	005291 and 006291	5	2900403
C2	005291 and 006291	5	2900404
C8	005291 and 006291	5	2900406
SCX	005291 and 006291	5	2900408
SAX	005291 and 006291	5	2900409
MEPS™ Development kit (contains 1 each of C18, C8, C2, SILICA and C8+SCX)	005291 and 006291	1	2900405
MEPS™ BIN for CTC Analytics systems using 250 µL syringe			
C18	006292	5	2900501
Silica	006292	5	2900502
C8+SCX*	006292	5	2900503
C2	006292	5	2900504
C8	006292	5	2900506
SCX	006292	5	2900508
SAX	006292	5	2900509
MEPS™ Development kit (contains 1 each of C18, C8, C2, SILICA and C8+SCX)	006292	1	2900505

Base material is silica with mean particle size of 45 µm and pore size of 60 Å. *C8+SCX BINS are labelled as M1.

For eVol® MEPS™ Applications. All LC needles are 55.5 mm in length, 22 gauge and dome tipped. All GC needles are 55.5 mm in length, 23 gauge and cone tipped.

Phase	LC Needle Part No.	GC Needle Part No.
C18	2900701	2900711
C8	2900702	2900712
C2	2900707	2900717
APS - amino-propyl silane	2900703	2900713
DVB - hydrophobic polystyrene-divinylbenzene copolymer	2900705	2900715
SDVB - styrene-divinylbenzene	2900706	2900716

All packs contain 5 MEPS™ BINs and can be used with 50, 100 and 500 µL eVol® MEPS™ syringes.

HPLC Supplies and Accessories

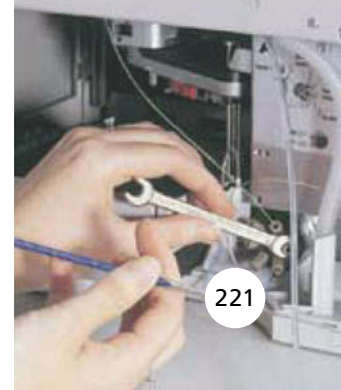



Particulate Protection for Your Columns

Expert Tip :

SGE fittings, guard cartridges and in-line filters are completely compatible with all other manufacturers' HPLC columns and systems.



HPLC Supplies and Accessories

- Zero dead volume filter design.
- Zero pressure drop across filter.
- Zero compromise on performance.

The ProteCol™ In-Line Filter is a simple and effective way to protect your capillary columns from particulates. It protects your system from blockages and increased back pressures without introducing peak tailing or loss of resolution. The filtering element

is a 2 micron porosity screen, located between the square-cut and polished ends of two lengths of PEEKsil™ tubing ('tails'). The construction of the in-line filter minimizes dead volume, providing optimum column performance. In-line filters are available with both 1/16" and 1/32" O.D. PEEKsil™ tails, providing versatility in connectivity and flexibility. The ends of the tails are precisely square cut and polished to achieve zero dead volume connections using ProteCol™ Unions.

Description	Inlet Length (mm)	Outlet Length (mm)	Tail ID (µm)	Tail OD	Pack Size	Part No.
ProteCol™ Filtering Connector 1/16"	50	50	50	1/16"	3	212005
ProteCol™ Filtering Connector 1/32"	50	50	50	1/32"	3	222012
ProteCol™ 1/32" In-line Filter Kit Includes: 3 x 1/32" In-Line Filters (P/N 222012), 2 x PEEK™ Fingertight fittings for 6-40UNF port (P/N 222017), 2 x PEEK™ Fingertight fittings for 10/32 port (P/N 222002).	50	50	50	1/32"	See description	222016

HPLC Supplies | In-line Filters



- Inert – biocompatible.
- Utilizes a replaceable 0.5 µm porosity frit assembly.
- Simple, cost effective means of sample filtration suitable for pre-column use.
- Low dead volume design eliminates peak broadening and enhances column resolving power.
- Supplied with Hexnuts™.

Description	Pack Size	Part No.
In-line Filter with a 0.5 µm Frit (supplied with holder)	1	204002
Replacement In-line Filter Frit Assembly	1	202009

Expert Tip:

If you can't pre-filter samples, make sure to use a low dead volume in-line filter after the injector.



HPLC Supplies | PEEKsil™ Tubing Kits



Description	Pack Size	Part No.
1/16" tubing kit (50 µm I.D. 100, 200, and 300 mm lengths)	5	212012
1/32" tubing kit (50 µm I.D. 100, 200, and 300 mm lengths)	5	222008

For other lengths of PEEKsil™ tubing see PEEKsil™ on page 239.

HPLC Supplies | PEEKsil™ Injection Loop

- Smooth, non-reactive internal bore reduces sample carry-over and sample rinse times.
- Reduced sample loss due to shear or adsorption.
- Maximum operating pressures are 3000 psi for 10 µL, and 20 µL loops.
- Supplied with PEEKsil™ tubing and two sets of stainless steel Hexnuts™ with PEEK™ ferrule fittings.
- Compatible with most valves including Rheodyne® and Valco®.

Volume	PEEKsil™ ID	Length	Pack Size	Part No.
10 µL	0.22 mm (0.009")	26 cm (10.24")	1	0650010
20 µL	0.22 mm (0.009")	53 cm (20.87")	1	0650020



Expert Tip :

For complete loop fill, the syringe capacity should be greater than twice the loop volume. The loop capacity sets the injection volume. For partial loop fill, the injection volume should be no greater than half the loop capacity. The injection size sets the injection volume.



HPLC Supplies and Accessories

HPLC Supplies | EasyLok™ Fittings

EasyLok™ fittings are composed of a knurled stainless steel nut and a double ended PEEK™ ferrule. The PEEK™ ferrule simply slides over any 1/16" OD tubing to its required position, while the nut is finger tightened. Unlike stainless steel, the PEEK™ ferrule will not crush the tubing and can be easily readjusted for quick column changes.

The unique double ended ferrule design seals at two points to prevent leaks.

The fittings are compatible with any standard female HPLC fitting including Swagelok®, Parker™, Waters®, Valco® and Whatman®.

EasyLok™ fittings are recommended for use with SGE GLT™ columns.

SPECIFICATIONS	
Maximum Pressure Rating	5,000 psi
Thread Type	10-32

Description	Pack Size	Part No.
EasyLok™ Fitting	2 fittings, 2 ferrules	206102
PEEK™ Double Ended Ferrules	10	206160



Expert Tip :

For quick and easy HPLC column connections use EasyLOK™ nuts.



HPLC Supplies | Hexnut™ Fittings

- Stainless steel 10-32 thread fittings use a non-swaging Kel-F® or PEEK™ replaceable ferrule.
- Inert contact surfaces make them biocompatible.
- Ideal for applications where corrosive solvents are being used.
- Hexnut™ with Kel-F® or PEEK™ ferrules are recommended for use with SGE GLT™ columns.

Specifications	
Maximum Pressure Rating	5,000 psi
Thread Type	10-32

Description	Pack Size	Part No.
Stainless Steel Hexnuts™ and PEEK™ Ferrules	2 hexnuts, 2 ferrules	1021003
Stainless Steel Hexnuts™ and PEEK™ Ferrules	10 hexnuts, 10 ferrules	1021011
Kel-F® Ferrules	10	0730010
Replacement PEEK™ Ferrules	2	0730004
Replacement PEEK™ Ferrules	10	0730014





Accumulated impurities during a column's life may block the column termination frits, making a replacement necessary. Frit porosity must be chosen to retain particles. Select appropriate replacement frit for column type and packing size.

Description	Pack Size	Part No.
1 mm ID micro column frit assembly (3 µm packing)	2	202016
1 mm ID micro column frit assembly PEEK®-PTFE frit	2	2020155
4 mm ID GLT™ column frit assembly (3 µm packing)	2	202002
2 mm ID GLT™ column frit assembly PEEK®-PTFE frit (5 µm packing)	2	2020035
Frit Removal Tool	1	200005

HPLC Supplies | ProteCol™ Unions, Ferrules and Fittings

HPLC Supplies and Accessories



Perfect Connections, Every Time

- Zero dead volume design for no peak dispersion.
- Easy to use.
- Complete versatility – allows connection to the same or a range of different size tubing.
- Available in PEEK™ and stainless steel.

- Stainless steel unions can be finger tightened or tightened with a 3/16" wrench for high-pressure applications.
- PEEK™ unions can be finger tightened. They are slightly larger than stainless steel unions but also lighter - less stress on your tubing.

Connectivity

ProteCol™ Unions and reusable PEEK™ ferrules allow you to connect any combination of:

Stainless steel or PEEK™ unions

ProteCol™ Unions are available in either stainless steel or PEEK™ (for all sizes). All use the same range of reusable PEEK™ ferrules.

- 1/32" PEEKsil™.
- 1/16" PEEKsil™.
- 0.36 mm fused silica tubing.

ProteCol™ Stainless Steel Unions

Description	Pack Size	Part No.
0.36 mm to 0.36 mm	2 unions and 4 PEEK™ Ferrules	222007
1/16" to 0.36 mm	2 unions and 4 PEEK™ Ferrules	212008
1/16" to 1/16"	2 unions and 4 PEEK™ Ferrules	212006
1/16" to 1/32"	2 unions and 4 PEEK™ Ferrules	212007
1/32" to 0.36 mm	2 unions and 4 PEEK™ Ferrules	222006
1/32" to 1/32"	2 unions and 4 PEEK™ Ferrules	222005

For your inert connection tubing solutions use PEEKsil™, see page 234.

ProteCol™ PEEK™ Unions

Description	Pack Size	Part No.
0.36 mm to 0.36 mm	2 unions and 4 PEEK™ Ferrules	222011
1/16" to 0.36 mm	2 unions and 4 PEEK™ Ferrules	212011
1/16" to 1/16"	2 unions and 4 PEEK™ Ferrules	212009
1/16" to 1/32"	2 unions and 4 PEEK™ Ferrules	212010
1/32" to 0.36 mm	2 unions and 4 PEEK™ Ferrules	222010
1/32" to 1/32"	2 unions and 4 PEEK™ Ferrules	222009

ProteCol™ PEEK™ Ferrules

Description	Pack Size	Part No.
0.36 mm to 0.36 mm	5	223007
1/16" to 0.36 mm	5	213008
1/16" to 1/16"	5	213006
1/16" to 1/32"	5	213007
1/32" to 0.36 mm	5	223006
1/32" to 1/32"	5	223005

PEEK™ Fingertight Fittings

Description	Pack Size	Part No.
1/16" to 10-32UNF	5	2062752
1/32" to 10-32UNF	5	222002
1/32" to 10-32UNF (long)	5	2062753
1/32" to 6-40UNF	5	222017



HPLC Supplies and Accessories



HPLC Supplies | High Efficiency HPLC Column Couplers

- Inert – biocompatible.
- Provide a rigid low dead volume, metal free connection between two components of an HPLC system.
- Ideal for connecting two HPLC columns, a HPLC column to a guard cartridge or in-line filter.

Specifications	
Maximum Pressure Rating	5,000 psi
Thread Type	10-32

Description	Pack Size	Part No.
Stainless Steel Hexnut™ Coupling Kit	1	200009
5 x Replacement PEEKsil™ tubing (1/16" x 175 µm ID x 50 mm) Part No. 0624351		
2 x Replacement PEEK™ Ferrules Part No. 0730004		
10 x Replacement PEEK™ Ferrules Part No. 0730014		



HPLC Supplies | Detector/Tubing Unions

- True zero dead volume unions enable connection of existing detector and other metal male fittings to the finger-tight compatible SGE column and cartridge systems.
- Available for Waters®, Swagelok®, Parker™, Valco® and Rheodyne® male fittings.



Description	Pack Size	Part No.
Union for Waters and Rheodyne tubing	1	2062746
Union for Swagelok®, Parker and Valco tubing	1	2062747



- SGE recommends that 4.0 mm ID Guards be used to protect all 4.6 mm and 4.0 mm ID HPLC columns.
- Vital for HPLC column protection.
- Inert, metal free - biocompatible flow path.
- Improved biological and ion chromatography.
- Pre-packed in a range of packing materials.

These inert, biocompatible cartridge systems offer maximum efficiency to protect the analytical column and begin the separation process.

Each of these guard cartridges has an effective length of 10 mm.

Guard Cartridge Holder

Description	Pack Size	Part No.
Guard Cartridge Holder	1	205000

Guard Cartridges

Description	Column ID (mm)	Pack Size	Part No.
Exsil™ ODS - 3 micron	4.0 and 4.6	3*	2050010
Exsil™ ODS - 5 micron	4.0 and 4.6	3*	2050001
Exsil™ Silica - 5 micron	4.0 and 4.6	3*	2050002
Exsil™ C8 - 5 micron	4.0 and 4.6	3*	2050003
Exsil™ Amino - 5 micron	4.0 and 4.6	3*	2050004
Exsil™ SCX - 5 micron	4.0 and 4.6	3*	2050005
Exsil™ SAX - 5 micron	4.0 and 4.6	3*	2050006
Exsil™ Cyano - 5 micron	4.0 and 4.6	3*	2050007
Exsil™ Phenyl - 5 micron	4.0 and 4.6	3*	2050008
Nucleosil® ODS - 5 micron	4.0 and 4.6	3*	2050014

* Holder not included

Note: Not for use with ProteCol™ HPLC analytical columns. Please refer to pages 208-210 for ProteCol™ range of guard columns.

HPLC Supplies and Accessories



Expert Tip :

Always use a guard cartridge to prolong column life.



- PTFE and porous glass membrane filter.
- Efficiently filters particles down to 1.2 μm with minimal pressure drop.
- Filters solvent as it is drawn from the reservoir.



Description	Pack Size	Part No.
Solvent Filter (1 μm)	1	204000

HPLC Supplies and Accessories

HPLC Accessories | SilFlow™ - New Splitter Technology

Using SGE's SilFlow™ technology of microchannels in wafers, the next generation of splitters is now available.

There are two configurations of wafers developed to enable connecting flow lines to external components in a GC or HPLC system.

SilFlow™ offers low dead volume connections, that are deactivated and can be easily installed. For further information on SilFlow™ technology see page 182.

Configuration Types

SilFlow™ Splitters are available in 3 port configuration for HPLC applications, and as 3 and 4 ports for GC. See page 185 for GC applications.

Kit Contents

Each kit comes complete with: wafer, fingertite tool, mounting bracket, appropriately sized ferrules and nuts, and blanking ferrules to assist with set up.



Description	Tubing Dimensions			For Tubing	Pack Size	Part No.
	Port A	Port B	Port C			
SilFlow™ HPLC 3 Port Splitter						
LC Kit (1/32)	1/32"	1/32"	1/32"	1/32	Kit	123740
LC Wafer (1/32)	1/32"	1/32"	1/32"	1/32	1	123741

Replacement Parts

Description	For Tubing	Pack Size	Part No.
SilFlow™ LC Nut 1/32"	1/32" OD	10	123708
SilTite™ Ferrule 1/32"	1/32" OD	10	073473





Tubing

Fused Silica Tubing	230
High Temperature Polyimide Coating	230
Acrylate Coating	230
Fused Silica Stability	231
Non-Deactivated Fused Silica	231
Deactivated Fused Silica Tubing	232
Methyl Deactivated Fused Silica Capillary Tubing	232-233
Phenyl Deactivated Fused Silica Capillary Tubing	233
Capillary Electrophoresis Tubing	233
PEEKsil™ Tubing	234-235
GLT™ (Glass Lined Tubing)	236-237
Stainless Steel Tubing	238
Terry-Tool Tubing Cutter	238

SGE has a number of unique tubing products (Glass Lined Tubing - GLT™, and PEEK™ coated fused silica tubing - PEEKsil™) that allow chromatographers to perform applications not possible without these formats.

Read on to learn more about how the choice of the correct tubing can enhance your chromatography and biotechnology applications.

Fused Silica Tubing



SGE has been manufacturing silica capillary for over 30 years and has brought together technologies employed by optical fiber and tube re-draw industries, and merged them with silica glass structure and surface sciences. This melding of technologies ensures a complete understanding of all aspects necessary for production of high purity and high quality capillary.

Coated fused silica capillary tubing exhibits remarkable flexibility, with most sizes capable of being looped to a bend radius of 1 inch without the glass fracturing. The key to this flexibility comes from the coating material that protects the glass from abrasive damage. The resins SGE uses are semiconductor grade polyimides that possess excellent high temperature and electrical insulating properties. The resins also offer exceptional scuff resistance, which is important for applications where the capillary is frequently handled.

High Temperature Polyimide Coating

- Low Coefficient of Thermal Expansion (CTE): closely matches glass substrate.
- High modulus of elasticity: low deformation when “stretched”.
- High tensile strength: supports “tight coiled” capillary applications.
- Continuous operation +400 °C: polyimide cross-linking ensures adequate thermal protection.
- Solvent resistant: cannot be damaged by laboratory chemicals.
- Moderately high modulus of elongation: good flexibility.

Acrylate Coating

- Resistant to UV breakdown: durable to UV exposure.
- Low surface tension finish: repels oil and water.
- Good optical properties: high light throughput from UV to IR.
- High modulus of elongation: good flexibility.
- Thermoplastic properties: excellent welding properties.
- Easy window production: either chemical or thermal.
- Zero residue on glass after window production.

Once the drawing process is complete, the capillary tubing is subjected to stress testing many times above general handling levels to ensure it is free from structural defects.

The capillary tubing features are:

- High homogeneity.
- 100% proof tested for strength.
- Excellent resistance to thermal shock.
- Chemical inertness.
- Standard polyimide temperature resistance to +400 °C – equivalent to other high temperature polyimides.
- Polyimide coating is chemically resistant.
- Acrylic coating UV transparent (>240 nm).
- Low dielectric constant, low dielectric loss.
- Impermeable to all gases (except H₂, He).

- Free of thermal hysteresis.
- Low weight loss (below devitrification temperature).
- Optical properties of uncoated – transparent above 180 nm.
- High intrinsic tensile strength.
- Uncoated, temperature resistant to 1000 °C.
- Pressure resistant to 1000 bar.
- Very low thermal expansion.
- Internal surface modification is available.

Internal Diameter	15 µm = ± 2 µm 25 µm = ± 2 µm 50 µm = ± 3 µm 250 µm = ± 6 µm 320 µm = ± 6 µm 530 µm = ± 10 µm
Outside Diameter	360 µm = ± 10 µm 430 µm = ± 10 µm 700 µm = ± 15 µm
Iron	< 8 ppb
Lithium	< 10 ppb
Sodium	< 8 ppb
Potassium	< 10 ppb
Magnesium	< 10 ppb
Manganese	< 5 ppb
Titanium	< 10 ppb
Chlorine	0 ppb
Zirconium	< 10 ppb

Table 1. Fused silica tubing specification

Fused Silica Stability

Fused silica is very stable chemically and shows excellent resistance to acids. These properties make it ideal for applications involving various solvents, distillation of acid solutions and organic reactions. However, in hydrofluoric and phosphoric acids, alkalis and alkali-metallized compounds, dissolution of silica glass and surface devitrification may occur.

Non-Deactivated Fused Silica

- Used in a wide range of capillary GC, HPLC and Bioanalytical applications.
- Made from high quality fused silica.
- Tubing protected with a high temperature Polyimide resin.

Non-Deactivated Fused Silica Capillary Tubing

ID (mm)	Tubing OD (mm)#	Length (m)	Pack Size	Part No.
0.005	0.285	10	1	062456
0.01	0.285	10	1	062458
0.025	0.15	10	1	062461
0.025	0.285	10	1	062460
0.025	0.363	Sold per meter as a continuous length *	1	062710
0.04	0.14	10	1	0624625
0.05	0.15	10	1	0624635
0.05	0.22	10	1	062463
0.05	0.363	Sold per meter as a continuous length *	1	062711
0.06	0.22	10	1	0624655
0.075	0.19	10	1	062466
0.075	0.363	Sold per meter as a continuous length*	1	062712
0.1	0.2	10	1	0624685
0.1	0.363	10	1	062469
0.1	0.363	25	1	062470
0.11	0.17	10	1	062454
0.11	0.17	25	1	062457
0.15	0.22	10	1	062472
0.15	0.22	25	1	062473
0.15	0.285	10	1	062474
0.15	0.363	Sold per meter as a continuous length *	1	062713
0.22	0.363	10	1	062475
0.22	0.363	25	1	062476
0.25	0.363	10	1	062492
0.32	0.43	10	1	062478
0.32	0.43	25	1	062479
0.53	0.68	10	1	062481
0.53	0.68	25	1	062482

*One meter is one unit, e.g. to order 14 meters of 0.150 mm ID x 0.363 mm OD, the order must be for 14 of Part No. 062713. This will be supplied as a continuous length of 14 meters.

Nominal OD.



Deactivated Fused Silica Tubing

Deactivated fused silica tubing is an essential ingredient in maintaining a high performance chromatography system. Deactivated Capillary tubing will suit almost all applications, including retention gaps (improving the solvent effect for splitless injection volumes – ensuring maximum resolution), guard columns (to increase the life expectancy of your capillary column) and transfer lines (interfacing the analytical column to a mass spectrometer, or allowing the column effluent to be split and diverted to different detector systems).

Larger bore deactivated tubing (0.22 – 0.53 mm) provides a chemically inert flowpath for sample introduction for Purge and Trap systems, Headspace Analyzers and Multidimensional Systems.

It is important to note that tubing used for the above applications needs to achieve the highest possible level of chemical inertness and thermal stability, ensuring no interference with the quantitative and qualitative processes of an analysis.

In addition, this tubing needs to have no retention of the solvent, minimal retention or interaction of the solute, and be wettable by the solvent of interest.

SGE range of tubing is:

- 0.025 – 0.53 mm ID.
- Quality guaranteed – individually tested performance of each 30 m length from which all shorter (2, 5 and 10 meter) lengths are prepared. A test report is included with each column providing a history of its performance.
- Chemically inert and thermally stable up to 380 °C.
- Suitable for organic and aqueous solvents.
- Ideal for biotechnology applications.
- Methyl deactivated for use with hydrocarbons (pentane, hexane, heptanes, iso-octane, aromatics and mixed solvents – n-paraffins/chlorinated solvents).
- Phenyl deactivated tubing is recommended to be used where wettability needs to be improved.

Custom tubing is available upon request, contact your local SGE office.

Tubing

For connections to be used with fused silica tubing, see pages 158-165.

Methyl Deactivated Fused Silica Capillary Tubing

Tubing ID (mm)	Tubing OD (mm) [#]	Length (m)	Pack Size	Part No.
0.025	0.285	2	1	062442
0.05	0.22	2	1	062444
0.05	0.363	2	1	06244503
0.06	0.22	2	1	062445
0.075	0.19	2	1	0624450
0.075	0.363	2	1	06244502
0.1	0.363	25	1	0624455
0.11	0.17	2	1	062446
0.11	0.31	2	1	0624459
0.125	0.363	2	1	06244501
0.15	0.22	2	1	0624460
0.15	0.22	5	1	0624461
0.15	0.22	10	1	0624463
0.15	0.363	2	1	0624465
0.15	0.363	5	1	0624475
0.17	0.3	2	1	0624491
0.17	0.3	5	1	062449

[#]Nominal OD.

Methyl Deactivated Fused Silica Capillary Tubing Continued

Tubing ID (mm)	Tubing OD (mm)#	Length (m)	Pack Size	Part No.
0.22	0.363	2	1	0624469
0.22	0.363	5	1	062447
0.22	0.363	5	5	064050
0.22	0.363	10	1	0624478
0.22	0.363	25	1	0624474
0.25	0.363	2	1	0624431
0.25	0.363	5	1	0624432
0.25	0.363	5	5	064051
0.25	0.363	10	1	0624434
0.32	0.43	2	1	0624470
0.32	0.43	5	1	0624471
0.32	0.43	5	5	064052
0.32	0.43	10	1	0624476
0.32	0.43	25	1	0624473
0.53	0.68	2	1	0624479
0.53	0.68	5	1	062448
0.53	0.68	5	5	064054
0.53	0.68	10	1	064033
0.53	0.68	25	1	064034

Nominal OD.

Phenyl Deactivated Fused Silica Capillary Tubing

Tubing ID (mm)	Tubing OD (mm)#	Length (m)	Pack Size	Part No.
0.22	0.363	5	1	064102
0.22	0.363	10	1	064103
0.25	0.363	5	1	064061
0.25	0.363	10	1	064062
0.32	0.43	5	1	064108
0.53	0.68	5	1	064114

Nominal OD.

For your ferrule solutions, see pages 158-161.

Capillary Electrophoresis Tubing

- Manufactured from precision bore tubing.
- Hydrophobic and hydrophilic surface treatments are available to enable tubing use with proteins, peptides and enzymes.
- Wide pH range.
- 30, 50, 75 and 100 µm ID.
- Column-to-column reproducibility.



Treatment Type	Phase	Polarity	pH range	Application
Untreated	Free silanol sites allow bonding.	N/A	N/A	Field coating
ES2	Amide, hydrophobic, hydrolytically stable.	Moderately polar	5-9	Proteins, peptides, enzymes
ES20	Polyethylene glycol phase, weakly hydrophilic.	Polar	2-10	Proteins, peptides

Description	Tubing ID (mm)	Tubing OD (mm)	Length (m)	Pack Size	Part No.
Untreated	0.03	0.363	1	1	062801
ES20 Treated	0.05	0.363	1	1	062881
Untreated	0.05	0.363	1	1	062803
ES2 Treated	0.075	0.363	1	1	062812
Untreated	0.075	0.363	1	1	062813
Untreated	0.1	0.363	1	1	062823



PEEKsil™ Tubing (Fused Silica Lined PEEK™)

Tubing



PEEKsil™ is polymer-sheathed fused silica tubing with an effective outside diameter of 1/32", 1/16" or 0.36 mm. SGE is the only manufacturer of this inert chromatography tubing. The sheathing polymer is polyether ethyl ketone (PEEK™) that is mechanically strong and has ideal characteristics for sealing with conventional metal or polymer ferrule systems. PEEKsil™ may be used as a direct replacement for conventional stainless steel as well as a replacement for PEEK™ tubing used in liquid chromatography systems. The PEEK™ polymer exterior coating and the fused silica combination (*Figure 1*) makes PEEKsil™ very robust. PEEKsil™ is therefore capable of withstanding high pressures (*Table 2*), making it ideal for capillary HPLC and LC/MS applications.

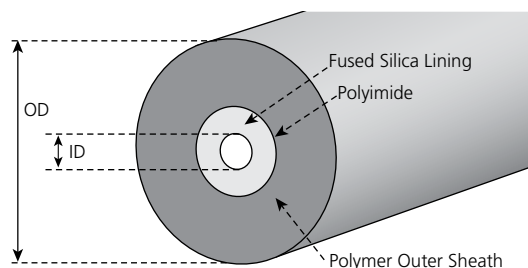

Figure 1.

Pressure Rating		
50 micron	≤	25,000 psi
100 micron	≤	15,000 psi
175 micron	≤	8,500 psi
200 micron	≤	6,000 psi

Table 2. Pressure Rating for PEEKsil™.

- PEEKsil™'s smooth wall allows lower carry over or cross contamination between samples which can lead to improved reproducibility.
- The smooth wall of PEEKsil™, particularly for smaller inside diameter HPLC column systems, gives lower band broadening and therefore higher efficiency and resolution.
- Small inside diameters of stainless steel tubing are prone to blockage. The smooth wall of fused silica tubing means that it is far less likely to block.
- PEEKsil™ is compatible with most organic solvents. PEEKsil™ is resistant to strong acids and has an effective pH range of 0-10. PEEKsil™ is not compatible with hydrofluoric acid.
- Fused silica is renowned for its extremely low absorption characteristics, especially when compared with the absorption of sensitive sample components on stainless steel.
- The inside diameter of fused silica tubing can be produced far more precisely and with a greater range of sizes than is available with stainless steel (see part number listing table on opposite page). 50 micron ID PEEKsil™ is perfect for LC/MS applications. Furthermore, the fused silica bore is unaffected by organic solvents, unlike PEEK™ tubing which is prone to contraction in some organic solvents.
- The use of PEEKsil™ complements SGE's full range of non-metallic HPLC columns (see pages 208-210 for ProteCol™ HPLC Columns) and cartridges to give a metal free HPLC analytical system. This is advantageous for ion chromatography and sensitive samples such as proteins.
- PEEKsil™ is inherently straight, but is very flexible, which makes connection between columns, detectors and injectors easier than with more rigid stainless steel tubing.

Expert Tip :

PEEKsil™ tubing is an excellent alternative to PEEK™ tubing as its internal bore is unaffected by any organic solvents.



- The flexibility of PEEKsil™ eliminates strain on components in precision HPLC systems. PEEKsil™ may also be coiled and used as the external loop of an injection valve.
- PEEKsil™ can be used in all applications where solvents must be pumped under high or low pressures with little flow resistance or possibility of contamination. Typical uses are in HPLC connecting lines, sample loops and sample lines.

Color	Tubing ID (mm)	Tubing OD	Length (mm)	Pack Size	Part No.
Orange	0.025	0.36 mm	50	2	0624371
Orange	0.025	0.36 mm	100	2	0624372
Orange	0.025	0.36 mm	150	2	0624373
Orange	0.025	0.36 mm	250	2	0624374
Orange	0.025	0.36 mm	500	2	0624375
Beige / Natural	0.05	0.36 mm	50	2	0624376
Beige / Natural	0.05	0.36 mm	100	2	0624377
Beige / Natural	0.05	0.36 mm	150	2	0624378
Beige / Natural	0.05	0.36 mm	250	2	0624379
Beige / Natural	0.05	0.36 mm	500	2	0624380
Orange	0.025	1/32"	50	2	0624241
Orange	0.025	1/32"	100	2	0624242
Orange	0.025	1/32"	150	2	0624243
Orange	0.025	1/32"	250	2	0624245
Orange	0.025	1/32"	500	2	0624249
Beige / Natural	0.05	1/32"	50	2	0624261
Beige / Natural	0.05	1/32"	100	2	0624262
Beige / Natural	0.05	1/32"	150	2	0624263
Beige / Natural	0.05	1/32"	200	2	0624264
Beige / Natural	0.05	1/32"	250	2	0624265
Beige / Natural	0.05	1/32"	500	2	0624269
Black	0.075	1/32"	50	2	0624271
Black	0.075	1/32"	100	2	0624272
Black	0.075	1/32"	150	2	0624273
Black	0.075	1/32"	250	2	0624275
Black	0.075	1/32"	500	2	0624279
Red	0.1	1/32"	50	2	0624311
Red	0.1	1/32"	100	2	0624312
Red	0.1	1/32"	150	2	0624313
Red	0.1	1/32"	250	2	0624315
Red	0.1	1/32"	500	2	0624319
Purple	0.15	1/32"	50	2	0624341
Purple	0.15	1/32"	100	2	0624342
Purple	0.15	1/32"	150	2	0624343

Color	Tubing ID (mm)	Tubing OD	Length (mm)	Pack Size	Part No.
Purple	0.15	1/32"	250	2	0624345
Purple	0.15	1/32"	500	2	0624349
Orange	0.025	1/16"	50	5	0624225
Orange	0.025	1/16"	100	5	0624226
Orange	0.025	1/16"	150	5	0624227
Orange	0.025	1/16"	200	5	0624228
Orange	0.025	1/16"	500	2	0624229
Beige / Natural	0.05	1/16"	50	5	0624251
Beige / Natural	0.05	1/16"	100	5	0624252
Beige / Natural	0.05	1/16"	150	5	0624254
Beige / Natural	0.05	1/16"	200	5	0624253
Beige / Natural	0.05	1/16"	500	2	0624250
Black	0.075	1/16"	50	5	0624290
Black	0.075	1/16"	100	5	0624291
Black	0.075	1/16"	150	5	0624292
Black	0.075	1/16"	200	5	0624293
Black	0.075	1/16"	500	2	0624294
Red	0.1	1/16"	50	5	0624301
Red	0.1	1/16"	100	5	0624302
Red	0.1	1/16"	150	5	0624304
Red	0.1	1/16"	200	5	0624303
Red	0.1	1/16"	500	2	0624300
Purple	0.15	1/16"	50	5	0624230
Purple	0.15	1/16"	100	5	0624231
Purple	0.15	1/16"	150	5	0624232
Purple	0.15	1/16"	200	5	0624233
Purple	0.15	1/16"	500	2	0624234
Yellow	0.175	1/16"	50	5	0624351
Yellow	0.175	1/16"	100	5	0624352
Yellow	0.175	1/16"	150	5	0624354
Yellow	0.175	1/16"	200	5	0624353
Yellow	0.175	1/16"	500	2	0624350
Blue	0.2	1/16"	50	5	0624202
Blue	0.2	1/16"	100	5	0624203
Blue	0.2	1/16"	150	5	0624205
Blue	0.2	1/16"	200	5	0624204
Blue	0.2	1/16"	500	2	0624201
Blue	0.25	1/32"	650	2	0624280
Grey	0.3	1/16"	50	5	0624214
Grey	0.3	1/16"	100	5	0624215
Grey	0.3	1/16"	150	5	0624216
Grey	0.3	1/16"	200	5	0624217
Grey	0.3	1/16"	500	2	0624218
Bone White	0.53	1/16"	50	5	0624365
Bone White	0.53	1/16"	100	5	0624366
Bone White	0.53	1/16"	150	5	0624367
Bone White	0.53	1/16"	200	5	0624368
Bone White	0.53	1/16"	250	2	0624369
Bone White	0.53	1/16"	500	2	0624370

Tubing

For HPLC connection fittings, see pages 227-229.



GLT™ (Glass Lined Tubing)



GLT™ (Glass Lined Tubing) was invented and patented by SGE to enable the achievement of a completely inert chromatographic system. It is made by fusing a borosilicate glass lining onto the inside surface of stainless steel tubing. GLT™ can either be used as straight tubing or it can be machined or shaped into virtually any chromatography accessory - the options are limitless.

- GLT™ exhibits excellent resistance to strong acids and bases unlike inferior silica coated brands.
- GLT™ is biocompatible making it ideal for many HPLC applications. A mirror surface finish allows high HPLC column efficiencies.
- GLT™ can withstand high temperatures. Maximum temperature for continuous use of GLT™ is 500 °C. The glass is secured to the steel wall because of the higher coefficient thermal expansion of the steel relative to the glass.
- GLT™ can be used for: reactor tubing transfer lines, flow lines for stack probes for environmental monitoring, HPLC columns for protein and biosensitive analyses, mass spectrometer interfaces,

thermal desorption tubes, inert tee pieces and unions.

- GLT™ can be formed into a multitude of shapes and can also be joined by welding or silver soldering.
 - Bending: GLT™ can be bent without damage to the glass lining by heating it with a gas-air burner in the region where the bend is required. When the metal tubing turns medium red (approximately 800 °C) it can be slowly bent to the desired angle while still in the flame. It is important that the tubing is not bent in the cold condition, or the glass lining will shatter.
 - Silver-Soldering: After first removing the black oxide layer, the metal sheath can be silver-soldered by conventional methods. It is important that excessive heat is not applied to the tubing, or the glass lining may become non-uniform. On completion of soldering, the components should not be quenched but allowed to cool slowly to ambient temperature. Take care not to allow hot flux to come into contact with the glass liner.

Tubing comes in a wide range of sizes with outer diameters of 1/16", 1/8", 1/4", 1/2" (standard), 8 and 4 mm (non-standard) and internal diameters between 0.3 – 9.5 mm. GLT™ can be machined to form union fittings and a range of other chromatography accessories. There is no limit to the range of applications GLT™ can service. Contact SGE for a complete custom-made solution to your flow, transfer and system operation problems.

GLT™ (Glass Lined Tubing)

Tubing ID (mm)	Tubing OD	Length (cm)	Part No.
0.3	1/16"	30	082707
0.3	1/16"	60	082708
0.3	1/16"	90	082709
0.3	1/16"	180	082710
0.4	1/16"	30	082712
0.5	1/16"	30	082717
0.5	1/16"	60	082718
0.5	1/16"	90	082719
0.5	1/16"	180	082720
0.7	1/16"	30	082722
0.7	1/16"	60	082723
0.7	1/16"	90	082724
0.7	1/16"	180	082725
0.8	1/16"	30	0827352
0.8	1/16"	60	0827353
0.8	1/16"	90	0827354
0.8	1/16"	180	0827355
0.5	1/8"	30	0827375
0.5	1/8"	60	0827376
0.5	1/8"	90	0827377
0.75	1/8"	30	082732
0.75	1/8"	60	082733
0.75	1/8"	90	082734
0.75	1/8"	180	082735
1	1/8"	30	082737
1	1/8"	60	082738
1	1/8"	90	082739
1	1/8"	180	082740
1.5	1/8"	30	082742
1.5	1/8"	60	082743
1.5	1/8"	90	082744
1.5	1/8"	180	082745
1.8	1/8"	30	082747
1.8	1/8"	180	082750
2	1/4"	90	082760
4	1/4"	30	082767
4	1/4"	60	082768
4	1/4"	90	082769
4	1/4"	180	082770
9.5	1/2"	60	08277028

Connections

Use of Swagelok® ferrules with larger ID GLT™ may result in cracking of the glass liner. The use of graphite ferrules is recommended for connecting GLT™. Swagelok® metal ferrules may only be used with 2 and 3 mm ID 1/4" OD, and 1.5 mm ID and under 1/8" OD GLT™.

Tubing

For the full range of SGE connections see the Connections section starting on page 158.



Stainless Steel Tubing



- Smooth and clean bore.
- Supplied in coils and enclosed in a stainless steel spiral mount. Where tubing OD is smaller than 1/16", ends are bushed to 1/16" and GC ferrules are supplied.
- 5, 10 and 25 meter lengths supplied cleaned and passivated.

Tubing OD	ID (mm)	Length (m)	Part No.
1/48"	0.25	25	062401
1/32"	0.5	25	062406
1/16"	0.8	2	062418
1/16"	0.8	5	0624160
1/16"	0.8	10	062416
1/8"	2.2	2	0624173
1/8"	2.2	5	062415

Tubing

Terry-Tool Tubing Cutter



- Cutting wheel for cutting 1/16" and 1/8" stainless steel tubing.
- Clean, right angle cuts with minimal burring or chipping of the tubing.
- No additional reaming or deburring is required.
- Spare cutting wheels are available.

Description	Tubing OD	Pack Size	Part No.
Terry Tool Stainless Steel Tubing Cutter	1/16"	1	082780
Terry Tool Stainless Steel Tubing Cutter	1/8"	1	082782
Replacement Wheel	n/a	3	082781



Electron Multipliers

Introduction to ETP Electron Multipliers	240-241
Selection by Technique:	
GC-MS	242
LC-MS	242
ICP-MS	242
TOF-MS	243
Magnetic Sector	243
Selection by Instrument	243-244

ETP Electron Multipliers are individually tested to ensure the highest quality.

Electron Multipliers



ETP Electron Multipliers, a wholly owned subsidiary of SGE is a world leader in the design and manufacture of ion detection and ion optics technologies for use in mass spectrometers. A wide variety of models has been designed and built to cover most common types of mass spectrometer, including ICP-MS, GC-MS, LC-MS/MS and MALDI across all mass analyzer types, quadrupole, ion trap, magnetic sector and time of flight.

SGE's ETP Electron Multipliers team has over 100 years combined experience in the design and fabrication of detectors for mass spectrometry applications.

Ion detection systems based on electron multipliers have been widely used as detectors of charged particles and high-energy photons in analytical instrumentation for more than 30 years. Their basic function of detection and amplification of very small signals has remained unchanged since the beginning; however, modern computer design and modeling techniques, as well as advancements in materials and manufacturing, have enabled development of extremely sensitive, yet rugged, devices vital to the performance of today's mass spectrometers. ETP electron multipliers from SGE are the most advanced high-performance detectors available today.

How Do They Work

An electron multiplier is used to detect the presence of ion signals emerging from the mass analyzer of a mass spectrometer (see *Figure 1*). The task of the electron multiplier is to detect every ion of the selected mass passed by the mass filter. How efficiently the electron multiplier carries out this task, represents a potentially limiting factor on overall system sensitivity. Consequently, the performance of the electron multiplier can have a major influence on the overall performance of the mass spectrometer.

The basic physical process that allows an electron multiplier to operate is called secondary electron emission. When a charged particle (ion or electron) strikes a surface it causes secondary electrons to be released from atoms in the surface layer. The number of secondary electrons released depends on the type of incident primary particle, its energy, and characteristics of the incident surface (see *Figure 2*).

Electron Multipliers

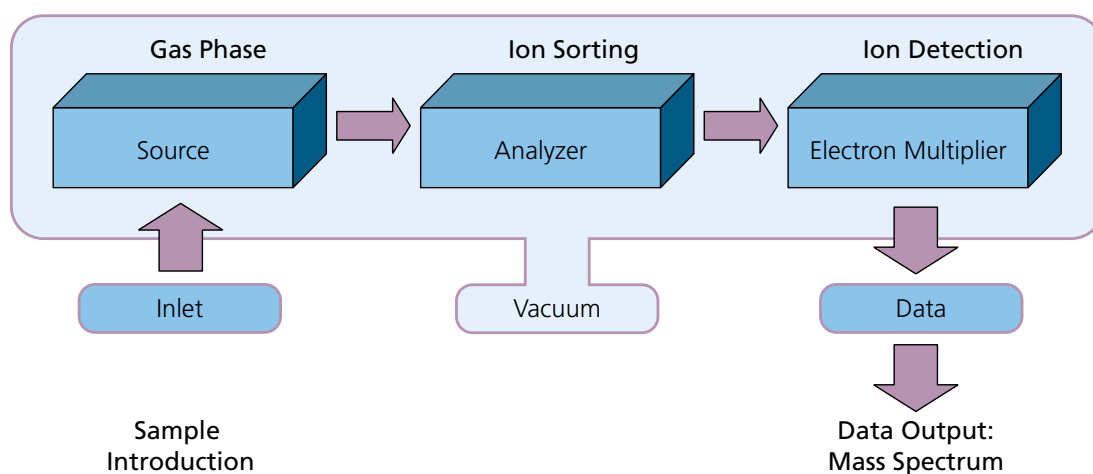

Figure 1. Components of Mass Spectrometry. The general layout of a mass spectrometer consists of the following elements; Sample introduction and separation system, Ion source, Mass analyzer, Ion detection system, Data processing.

Expert Tip :

Operate at the lowest voltage consistent with desired results.



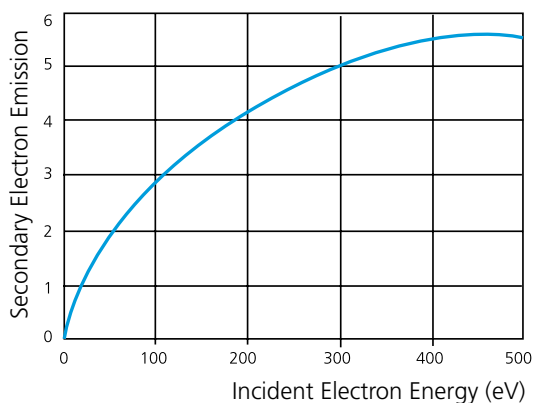

Figure 2. Secondary Electron Emission. The average number of secondary electrons emitted from the surface of an ETP electron multiplier plotted against the energy of the incident primary electron.

There are two basic forms of electron multipliers that are commonly used in mass spectrometry:

- The discrete-dynode electron multiplier.
- The continuous-dynode electron multiplier (often referred to as a channel electron multiplier or CEM).

All ETP electron multipliers are of the discrete-dynode type (see Figure 3).

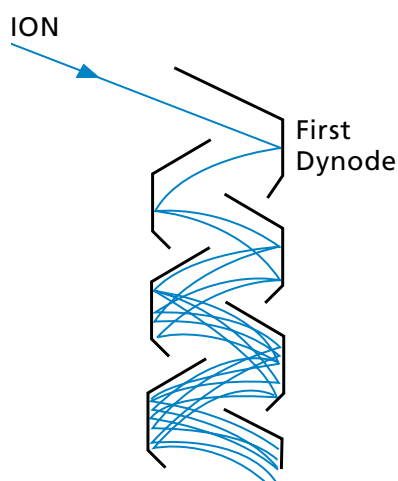

Figure 3. Ion-optics of an ETP discrete-dynode electron multiplier showing the electron gain at each successive dynode. This electron cascading process results in gains up to 10^8 being achieved with ~21 dynodes.

A typical discrete-dynode electron multiplier has between 12 and 24 dynode stages, and is used at an operating gain of between 10^4 and 10^8 , depending on the application. In GC-MS applications, for example, the electron multiplier is typically operated in analog mode with a gain of around 10^5 . For a new electron multiplier this gain is typically achieved with an applied high voltage of ~1400 volts.

Features

ETP Electron Multipliers manufactured by SGE use a proprietary dynode material. This material has a number of properties that make it very suitable for use in an electron multiplier. It has very high secondary electron emission, which allows exceptional gain to be achieved from each dynode. This material is also very stable in air. In fact, an ETP electron multiplier can be stored for years before being used. As a direct result of the high stability of the active materials used in ETP electron multiplier, they come with a 2 year shelf life warranty. Many testing laboratories take advantage of this long shelf life by keeping a replacement ETP electron multiplier on hand, ready for immediate installation. This keeps the instrument down time to a minimum.

For a typical ETP electron multiplier for GC-MS, the total active dynode surface area is ~1000 mm². This can be compared to a standard continuous-dynode multiplier that has a total channel surface area of only around 160 mm² (for a channel with 1mm diameter and 50 mm length). This increased surface area spreads out the “work-load” of the electron multiplication process over a larger area, effectively slowing the aging process and improving operating life and gain stability. These unique features lead directly to a range of benefits outlined below.

Benefits

- Optimized sensitivity for each mass spectrometer type.
- High dynamic range.
- Long operational lifetime.
- Two-year shelf life guarantee.

Expert Tip :

Do not apply power if multiplier has been contaminated by pump oil.





Part No. 14511

Expert Tip :

Store your multiplier in the original container when possible.



Electron Multipliers



Part No. 14516



Part No. 14617



Part No. 14210

For your instrument specific leak-free SilTite™ ferrules refer to the Instrument Quick Pick Guide on pages 167-180.

GC-MS

Instrument	Analyzer Type	Technique	Part No.
Agilent Technologies			
5970 (All)	Quadrupole	GC-MS	14511
5971, 5972, GCD	Quadrupole	GC-MS	14516
5973 (For initial installation - includes mount)	Quadrupole	GC-MS	14617
5973 (Replacement multiplier only)	Quadrupole	GC-MS	14616
JEOL			
K-9 (For initial installation-includes mount)	Quadrupole	GC-MS	14632
K-9 (Replacement multiplier only)	Quadrupole	GC-MS	14630
Shimadzu			
QP 5000	Quadrupole	GC-MS	14533
Varian			
Saturn 2000, 2100, 2200	Ion Trap	GC-MS	14147

LC-MS

Instrument	Analyzer Type	Technique	Part No.
AB Sciex			
API 2000	Quadrupole	LC-MS	14610
API 3200	Quadrupole	LC-MS	14610
3200 Q-TRAP	Quadrupole	LC-MS	14610

ICP-MS

Instrument	Analyzer Type	Technique	Part No.
Agilent Technologies			
4500	Quadrupole	ICP-MS	14573
7500	Quadrupole	ICP-MS	14222
GBC			
OptiMass	TOF	ICP-MS	14834H
PerkinElmer			
ELAN 9000, DRC	Quadrupole	ICP-MS	14217
ELAN 6000, 6100, 6100 DRC	Quadrupole	ICP-MS	14210
Thermo Scientific			
PQ (SXP rods)	Quadrupole	ICP-MS	14562A
PQ-3, Excel (Sequential)	Quadrupole	ICP-MS	14562A
PQ-3, Excel (Simultaneous)	Quadrupole	ICP-MS	14214
Varian			
UltraMass	Quadrupole	ICP-MS	14566

Expert Tip :

Set power supply to lowest, or default, setting when installing a new multiplier.



TOF-MS

Instrument	Analyzer Type	Technique	Part No.
Amersham			
Amersham Ettan	TOF	MALDI-TOF	14824
BioRad (Ciphergen)			
Protein Chip (2)	TOF	MALDI-TOF	14875
Comstock			
MiniTOF	TOF	TOF	14824
GBC			
OptiMass	TOF	ICP-MS	14834H
Kratos			
Kompact MALDI	TOF	MALDI-TOF	14820
Axima (Linear)	TOF	MALDI-TOF	14870
Axima (Linear-High Dynamic Range)	TOF	MALDI-TOF	14874
SENSAR/LARSON-DAVIS			
TOF 2000	TOF	TOF	14823H

Magnetic Sector

Instrument	Analyzer Type	Technique	Part No.
CAMECA			
3F, 4F	Magnetic Sector	SIMS	14133
5F, 6F	Magnetic Sector	SIMS	14133H
Nu Instruments			
Nu Plasma	Magnetic Sector	Isotope Ratio	14143
Nu Plasma with filter	Magnetic Sector	Isotope Ratio	14144
Thermo Scientific (Finnigan MAT)			
MAT 262	Magnetic Sector	Isotope Ratio	14150HM9

Expert Tip :

Ensure all connections have been properly made.



Part No. 14143

Electron Multipliers



Part No. 14133H

Electron Multipliers | Selection by Instrument

Instrument	Analyzer Type	Technique	Part No.
AB Sciex			
API 2000	Quadrupole	LC-MS	14610
API 3200	Quadrupole	LC-MS	14610
3200 Q-TRAP	Quadrupole	LC-MS	14610
Agilent Technologies (HP)			
4500	Quadrupole	ICP-MS	14573
7500	Quadrupole	ICP-MS	14222
5970 (All)	Quadrupole	GC-MS	14511
5971, 5972, GCD	Quadrupole	GC-MS	14516
5973 (For initial installation - includes mount)	Quadrupole	GC-MS	14617
5973 (Replacement multiplier only)	Quadrupole	GC-MS	14616
Amersham			
Amersham Ettan	TOF	MALDI-TOF	14824
BioRad (Ciphergen)			
Protein Chip (2)	TOF	MALDI-TOF	14875
CAMECA			
3F, 4F	Mag Sector	SIMS	14133
5F, 6F	Mag Sector	SIMS	14133H
Comstock			
MiniTOF	TOF	TOF	14824

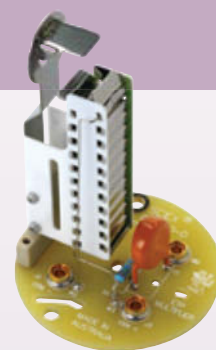

Part No. 14610

Expert Tip :

Handle only using powder-free gloves.



Part No. 14632

Electron Multipliers



Part No. 14147

Instrument	Analyzer Type	Technique	Part No.
GBC			
OptiMass	TOF	ICP-MS	14834H
JEOL			
K-9 (For initial installation-includes mount)	Quadrupole	GC-MS	14632
K-9 (Replacement multiplier only)	Quadrupole	GC-MS	14630
KORE Technology			
MS 200	TOF	TOF	14824
Kratos			
Kompact MALDI	TOF	MALDI-TOF	14820
Axima (Linear)	TOF	MALDI-TOF	14870
Axima (Linear-High Dynamic Range)	TOF	MALDI-TOF	14874
Nu Instruments			
Nu Plasma	Mag Sector	Isotope Ratio	14143
Nu Plasma with filter, Nu AttoM	Mag Sector	Isotope Ratio	14144
PerkinElmer			
ELAN 9000, DRC	Quadrupole	ICP-MS	14217
ELAN 6000, 6100, 6100 DRC	Quadrupole	ICP-MS	14210
SENSAR/LARSON-DAVIS			
TOF 2000	TOF	TOF	14823H
Shimadzu			
QP 5000	Quadrupole	GC-MS	14533
Thermo Scientific (VG Elemental)			
PQ (SXP)	Quadrupole	ICP-MS	14562A
PQ-3, Excel (Sequential)	Quadrupole	ICP-MS	14562A
PQ-3, Excel (Simultaneous)	Quadrupole	ICP-MS	14214
MAT 262	Mag Sector	Isotope Ratio	14150HM9
Varian			
UltraMass	Quadrupole	ICP-MS	14566
Saturn 2000, 2100, 2200	Ion Trap	GC-MS	14147

Expert Tip :

Use only non-polar solvents for cleaning. See the care and handling booklet supplied with each electron multiplier for details.



For your instrument specific leak-free SilTite™ ferrules refer to the Instrument Quick Pick Guide on pages 167-180.



Method Development and Troubleshooting

GC Method Development	246-249
GC Troubleshooting	250-251
HPLC Method Development	252
HPLC Troubleshooting	253-254

When developing a method for gas chromatography, three important considerations are:

1. Instrumentation.
2. Column selection.
3. Parameter optimization for rapid, high-quality separations.

1. + 2. Considerations for Instrumentation and Column Selection

Sample Injection

To analyze a new type of sample, the first thing to consider is the volatility of your sample. The table below outlines the recommendations according to sample volatility.

	Volatile Samples	Medium Volatility Samples	High/Very High Boiling Samples
Boiling Point Range.	Gaseous or easy to vaporize samples.	Boiling point range 50 – 300 °C.	Boiling point above 250 °C.
Sample Example.	Volatiles in drinking water, Residual solvents in pharmaceuticals.	EPA Semi-volatiles, Diesel Analysis, Pesticides, FAME's, Fragrances.	Simulated Distillation, Wax Analysis, Triglyceride Analysis.
System Requirements.	Cooling may be required for the GC oven.	Proper combination of inlet liner and injector mode.	Proper combination of inlet liner and injector mode.
Injection Recommendation.	Direct injection may work for some aqueous samples. Please see further recommendations for non-liquid techniques.	1) Split Injection. This should be adjusted according to the inner diameter of the column. 2) Splitless Injection is recommended for Trace Analysis. More complicated due to high level of accuracy required when setting parameters.	On Column Injection
Liner Recommendation.	Conectite liner.	FocusLiner™ (containing deactivated quartz wool).	Tapered FocusLiner™.
Septa Recommendation.	Septa with temperature rating up to 200 °C.	Septa with temperature rating up to 300 °C.	High temperature septa up to 400 °C.
Further Recommendations.	Head Space or Purge and Trap unit will enable automation of the analysis – for this a narrow bore inlet liner would be recommended	Large volume injection may be considered as an injection method to enhance sample sensitivity.	PTV (Programmable Temperature Vaporizer) inlet may be used. Two basic types – split or direct inject.

Detector Selection

For your instrumentation, you need to consider which detector will be suitable to determine the compounds of your sample. Most widely used as universal detectors are the FID and the MS, but you may consider using other detectors for specific requirements like ECD, TCD, FPD, or more sophisticated detectors.

Column Dimensions

The best column dimension selection is based on:

1. Detector type – determines column ID.
2. Number of compounds to analyze will determine column length.
3. Sample volatility impacts on film thickness required.

Remember, the best result will be with the shortest column and thinnest film your sample allows.

	Atmospheric Detectors	MS Detectors
Column ID	0.18 mm – 0.53 mm	0.1 mm – 0.32 mm

	Small number of compounds with wide range of boiling points/chemical properties	Number of compounds between 10 to 50	Number of compounds greater than 50
Column Length	10 m to 15 m	30 m	50 m or 60 m (rare cases, lengths of 100 m or 120 m can be used)

Sample Type	Volatile	Classical Volatiles (boiling points between 5 °C and 175 °C)	Wide Range of Medium Boiling Compounds	High Boiling Point Compounds
Film Thickness	Thicker films required to retain the compounds sufficiently for separation. 3 µm to 5 µm films or PLOT (Porous Layer Open Tubular)	1 µm to 2 µm films	0.25 µm	Thin film 0.1 µm

Column Phase

When selecting the column phase you need to consider the composition of the sample. Does the sample consist predominantly of non-polar, medium polar or strongly polar compounds?

Compound Polarity	Non-Polar Compounds	Medium Polar Compounds	Strongly Polar Compounds (short chain) (alcohols, aldehydes, esters, ketones and the medium boiling aromatic)
Phase Polarity Recommendation	Non-polar	Medium polar	Polar
Phase Type	100% Methyl Polysiloxane	5% Phenyl Polysiloxane	Polyethylene Glycol (wax)
Recommended Columns	BP1 and SolGel-1ms™	BP5 and BPX5	BP20 and SolGel-WAX™

There is one general column that can be used for a wide range of standard samples - this is a 30 m BPX5 column with 0.25 mm ID and 0.25 µm standard film thickness. With this column you will be able to perform up to 80% of general sample analysis. For more information on SGE GC Column phase polarity see pages 76-80.

3. Parameter Optimization for Rapid, High-quality Separations

Carrier Gas and Velocity

The first choice to be made is the selection of the carrier gas and the setting of the carrier gas velocity.

	Nitrogen	Helium	Hydrogen
Renewable Resource	Yes	No	Yes
Optimum Gas Velocity	10 to 15 cm/sec	30 to 35 cm/sec	40 to 45 cm/sec
Analysis Time Based on Optimum Gas Velocity	Long	Medium	Short
Limitations	Long analysis times	Expensive	Risk of explosion should column break, if more than 4% of Hydrogen in air
Minimization of Limitations	-	-	1) Use of Hydrogen generator which has a flow regulator and a safety "Shut Off" if too much Hydrogen is present 2) Safety system, which controls the air in the GC oven and shuts the heating and the carrier gas off, if the Hydrogen content in the oven air goes over 2 - 3% (which is below the level where an explosive mixture can be formed)
Best Suited For	Mixtures with small number of compounds that can be analyzed isothermally	GC/MS as Helium is easier for vacuum systems to pump off and has also some advantages in standard GC usage	Narrow bore columns

The optimum average gas velocity can be determined using the Van Deemter Equation:

$$\text{HETP} = A + B/u + Cu$$

HETP = Height equivalent to a theoretical plate

A = Eddy diffusion

B = Longitudinal diffusion

C = Resistance to mass transfer

u = Mobile phase velocity

Using this equation, Van Deemter Plots can be calculated (see figure to the right).

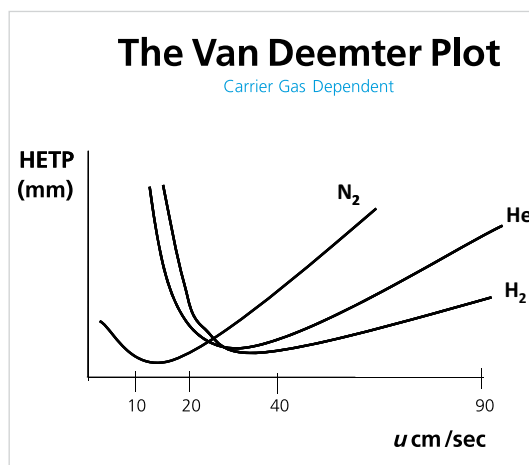

Time (seconds) needed for a non-retained compound to elute at optimum gas velocity

Column Length (m)	Helium (25 cm/sec)	Hydrogen (40 cm/sec)
12	50	30
15	60	37
25	100	60
30	120	73
50	200	120
60	240	146

Retention time in seconds (dead volume) for a non-retained compound.

Column Length (m)	He Carrier Gas (24 cm/sec)	H ₂ Carrier Gas (40 cm/sec)
12	48	29
15	60	37
25	100	60
30	120	73
50	200	120
60	240	146
100	400	240

Average column flow (mL/min) for various column diameters and average linear velocities.

Column ID (mm)	Flow Velocity (cm/sec)									
	10	20	25	30	35	40	50	60	70	80
0.1	0.05	0.09	0.12	0.14	0.16	0.19	0.24	0.28	0.33	0.38
0.15	0.11	0.21	0.27	0.32	0.37	0.42	0.53	0.64	0.74	0.85
0.22	0.23	0.46	0.57	0.68	0.80	0.91	1.14	1.37	1.60	1.82
0.32	0.48	0.97	1.21	1.45	1.69	1.93	2.41	2.90	3.38	3.86
0.53	1.32	2.65	3.31	3.97	4.63	5.29	6.62	7.94	9.27	10.59

Note: Average column flows listed are calculated values from respective average column velocities and not absolute measurements.

$$F \text{ (mL/min)} = F \text{ (cm/sec)} \cdot 60 \pi \left(\frac{d}{20} \right)^2$$

where d = column I.D. (mm)

Conversely, the conversion from cm/s to ml/min is given by:

$$F \text{ (cm/sec)} = \frac{F \text{ (mL/min)}}{60 \pi \left(\frac{d}{20} \right)^2}$$

Oven Temperature

	Isothermal Conditions	Temperature Program
Sample Type	Use for simple mixture	Use where the last eluting compound needs more time for elution and gives a broad peak, or where there is a separation problem in the area of the low boiling compounds.
Suited For	Split	Direct
Temperature Settings	Starting temperature - boiling point of the major compounds. If complete separation is occurring, the temperature can be increased. If there appears to be lack of separation then lower the temperature.	Temperature program should start as low as needed to separate the early eluting compounds. Temperature then increases at a certain rate to achieve the separation in the middle part of the chromatogram. The final temperature should be sufficiently high to ensure the last compound elutes within the temperature program. Going higher but staying below the maximum usage temperature of the phase and having an isothermal period at the end, helps to bake out high boiling compounds. An isothermal period at the beginning of the program improves the separation of low boiling compounds, but should be kept as short as possible.
Advantages	Samples can be run in series without having to accommodate a cooling cycle for the GC oven. Lifetime of the column will be extended provided it is not contaminated with high boiling point compounds.	Analysis can then be optimized by adjusting the temperature parameters as specified above. Fine tuning can include a two step temperature program, or including an isothermal plateau. If there is sufficient separation, the temperature rate can be increased to shorter retention times, giving you increased sample throughput.

Detector and Injector Temperatures and Split Ratio

Parameters to Set	Considerations
Detector Temperature	Should be set at least as high or slighter higher than the end temperature of the temperature program.
Injector Temperature	Set to approximately the same temperature as oven temperature - high enough to vaporize the whole sample in a short time, however, can be limited if some of the sample compounds are thermally labile. The lower the injector temperature to evaporate your sample the better for consistent analysis.
Split Ratio	Setting a low value (5:1 or 10:1) will result in poor sample transfer and broad peaks. Setting a high value will cause loss of sample – especially of compounds with low concentrations. For a standard column (30 m x 0.25 mm ID and 0.25 µm film) a split ratio between 50:1 and 100:1 is appropriate.

Column Performance Formulas

Capacity Ratio

$$K = t_R - t_m / t_m = t'_R(N+n) / t_m$$

Column Coating Efficiency

$$N_{\text{theoretical}} = 5.54 (t_R / W_h)^2$$

$$N_{\text{effective}} = 5.54 (t_R - t_m / W_h)^2$$

Kovats Retention Indices

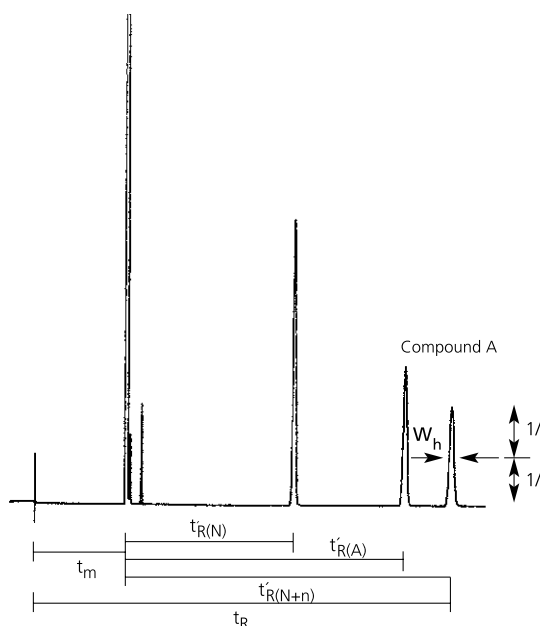

$$I_A = 100N + (100n(\log t'_R(A) - \log t'_R(N) / (t'_R(N+n) - \log t'_R(N))))$$

I_A is the retention index of compound A (from corrected retention times) which elutes between two n-paraffins separated by either one or two carbon numbers.

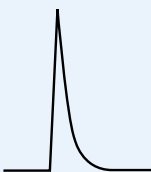
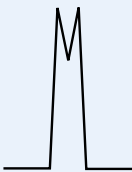
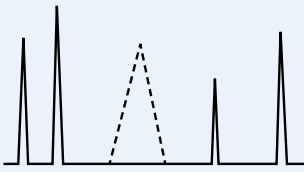

Problem	Resolution
No column flow	<p>Check carrier gas flow and adjust. Replace septum/injector seal with Auto-Sep T™ septum. Visually check column integrity i.e. is it broken? Remove section if small enough or replace column.</p>
High column bleed	<p>Check published maximum temperature. Check carrier flow rates / velocity, correct for column/length – adjust if necessary. Check column has not moved in detector. Check for leaks produced during initial heating especially Vespel® ferrules. Check oxygen filter is not spent – replace if necessary. Make sure detector temperature is higher than final column temperature if possible. Check cleanliness of detector – clean if necessary. Recondition column – re-run conditioning program. Cut 50 cm from the front end of the column.</p>
Retention time shifts	<p>Check temperature program. Check injector temperature. Ensure manual injection technique is consistent. Check carrier gas flow rate / velocity. Check for injector leaks. Ensure same solvent being used. Column is contaminated - rinse or replace. Remove 50 cm from front of column. Phase breakdown – replace column.</p>
Poor resolution or loss of resolution	<p>Use correct column or phase. Use different temperature program. Check injector temperature – is it correct for solvent and analytes. Check injection technique. Check carrier flow / velocity. Sample overload - dilute or change split ratio. Contaminated column – rinse or replace. Phase breakdown – replace column.</p>
Phase breakdown	<p>Check for leaks and repair. Check oxygen traps and replace if necessary. Exceeded upper temperature limit of column for extended periods – replace column. Column contamination – replace column (perform extra clean up of samples). Damage due to sample – do not inject strong acid or base samples.</p>
Poor or no detector response for all peaks	<p>Correct injection technique for concentration of analyte. Check proper liner is used for injection technique. Check syringe needle not blocked or plunger is leaking. Check split ratio if using split technique. Check injector temperature is correct. Check detector temperature is correct. Check flow rates of detector gas(es). Error in sample concentration – verify concentrations.</p>
Detector problems	<p>PID - Dirty window – clean according to manufacturer's specifications. ELCD - Faulty reactor tube. - Contaminated alcohol. - Incorrect alcohol flow rate. ECD - Impurities in nitrogen. - Dirty detector; clean (bake) according to manufacturer's specifications. NPD - Bad bead. FID - Partially blocked jet. FPD - Incorrect gas flow rates. - Incorrect filter installed. - Clean filter. TCD - Balance flow rates.</p>

Poor Peak Shape

Problem	Reason	Resolution
Peak Fronting 	Column overload.	Reduce sample concentration or injection volume.
	Incorrect polarity of column for compound.	Use correct column (see column selection section pages 80-81).
Peak Tailing 	Column is active.	Remove first meter of column; recheck; replace column if necessary.
	Active inlet liner.	Replace liner with clean, deactivated liner (for more information on SGE liner deactivation see page 157).
	Incorrect column for analysis.	Use correct column (see column selection section page 80-81).
	Incorrect column installation.	Check inlet and outlet connections, and for any cold spots.
Peak Splitting 	Poor injection technique.	Refine injection technique.
	Mixed solvents.	Use only single solvent system.
	Poor resolution.	Use different column or change temperature profile.
Ghost Peaks 	Run GC without injection; if ghost peaks disappear then the problem is probably the syringe or solvent; if ghost peaks are still evident then the problem is either the septum or the breakdown of the phase.	
	Contaminated syringe or solvents.	Clean syringe thoroughly and replace solvents.
	Septum bleed.	Replace with new Auto-Sep T™ septum (see Instrument Quick Pick Guide 167-180).
	Breakdown of column phase.	Choose different phase which restricts breakdown.
	Too large an injection volume.	Decrease injection volume.
Specific Peaks Low Response 	Column is active.	Remove first meter of column; recheck; replace column if necessary.
	Active inlet liner.	Replace liner with clean, deactivated liner.
	Incorrect calculation of sample.	Verify calculations.
	FID altered gas flows.	Readjust gas flows.

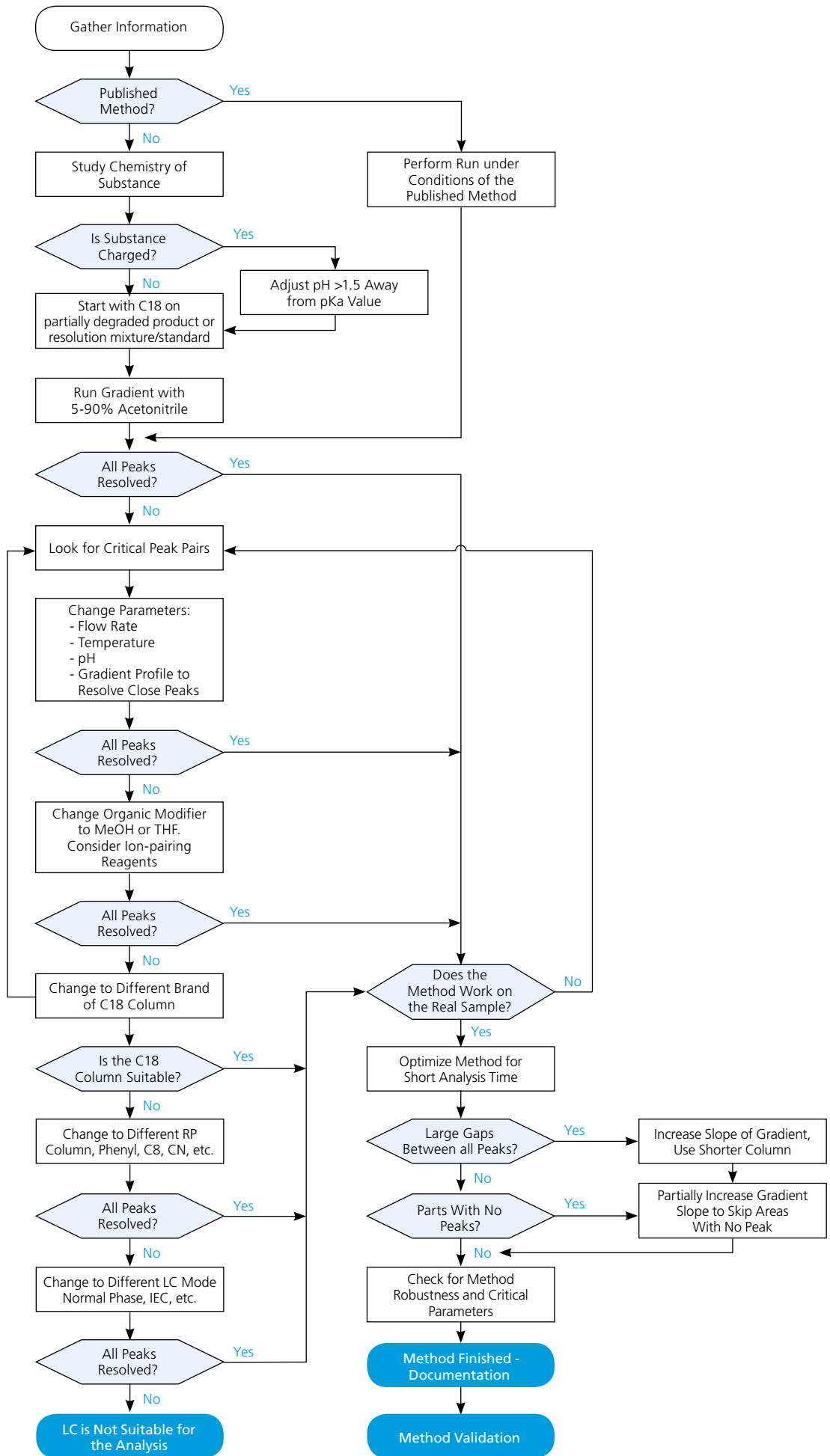

Problem	Reason	Resolution
System Related		
Low/unsteady system pressure.	Leak.	Check all connections and tighten connections, replace seals.
	Air in pump head.	Degas mobile phase and purge system.
	Dirt in check valve (check whether valve cannot close).	Firstly try purging system at high flow rate to dislodge contamination. Secondly, disassemble check valve and sonicate.
High system pressure.	Blockage (contamination).	Open connections sequentially from the detector back to the pump to locate blockage. Flush capillaries, replace in-line filters or guard columns, clean injector valve, reverse column flow (without detector in-line!) depending on where the blockage was located.
	Blockage (precipitated buffer salts) can happen when the system or user suddenly changes mobile phase composition from high organic to aqueous buffer or vice versa.	Disconnect column and flush with pure water at low flow rate to dissolve buffer salts again.
	High viscosity mobile phase.	Increase temperature, change mobile phase, or decrease flow rate.
	Small stationary phase particles.	Increase temperature, reduce flow rate, use shorter column.
Noisy, fluctuating, drifting baseline.	Crushed particles (sudden pressure spikes can cause porous silica to fracture and generate "fines").	Replace the column (see ProteCol™ HPLC columns pages 208-210).
	System contamination.	Disconnect column and rinse system with a combination of acid (10% nitric acid or 15% phosphoric acid for a short period of time followed by water and a organic wash of 75% acetonitrile/25% IPA over night) Do NOT run the acid through the column!
	Age of the UV lamp.	Replace the UV lamp.
	Temperature fluctuations.	Use column oven.
	Higher UV absorption of either mobile phase A or B causes drift in gradient elution.	Use HPLC grade solvents, check UV cut-off values for mobile phase components, change to higher wavelength.
Regular pulsing of the baseline.	Air in pump head (also causes pulsing of the back pressure).	Degas mobile phase and purge system.
	Dirt in check valve (also causes pulsing of the back pressure).	First try purging system at high flow rate to dislodge contamination. Second disassemble check valve and sonicate.
	Bubble trapped in the flow cell – the detector response changes dramatically when the detector outlet is temporarily blocked with a finger.	Degas mobile phase and purge system.
The Chromatogram		
Tailing peaks.	Wrong pH (some peaks are tailing while others are symmetrical).	The pH of the mobile phase should be 1.5 units or more above or below the pKa value of the analyte to have all molecules either in the charged or in the neutral state.
	Void volumes (all peaks are tailing).	Check connections, replace guard column, replace column.
	Non-specific interactions (some/all sample components can interact with active sites in the flowpath - silanol groups, metal surfaces of tubes and frits).	Replace column with an inert column, replace metal tubing (see inert PEEKsil™ tubing pages 238-239), add additives (e.g. EDTA) into mobile phase, lower pH to <2.5 in order to protonate silanol groups.
Fronting/tailing peaks.	Channeling.	Channeling indicates a serious problem with the column and the column needs replacing. For the interim one can try to reverse the column flow direction.
	"Viscous fingering" – happens when there is a large difference between the viscosity of the sample and the viscosity of the mobile phase.	Try to match the viscosity of the sample with the mobile phase. Ideally, always use mobile phase as diluent.
	Stationary phase degradation.	Loss of ligands when the column is exposed to extreme pH or when the column is very old can lead to peak fronting. Replace the column.
	Column over loading.	Reduce the amount of sample injected or use a column with a larger ID.

Problem	Reason	Resolution
Broad but symmetrical peaks.	Column over loading / sample volume too large.	Reduce the amount of sample injected or use a column with a larger ID.
	Poor column efficiency.	Optimize running conditions (flow rate, temperature) use column with smaller particles, reduce extra column volumes.
	Late eluting sample components from the previous injection.	Use double injections – late eluters only appear in the second run. Extend run time, use strong eluting wash step, use gradient.
Ghost peaks.	Carry-over from contaminated injector.	Clean system/injector until obtaining a clean blank.
	Contaminated mobile phase A in a gradient elution.	Make fresh mobile phase. Use only HPLC grade solvents.
	Air bubbles.	Air bubble cause very sharp spikes. Degas solvents.
	Electronic interference.	Check for source of interference. Use independent power source.
Shifting retention times.	Change in temperature.	Use column oven or operate in a temperature controlled laboratory.
	Mobile phase not mixed properly.	Make sure the mobile phase is well mixed (isocratic) or the solvent mixer (proportioning valve or pump heads A and B) is working correctly (gradient).
	Solvent evaporation.	Make sure solvent bottles are capped.
	Column contamination.	Build-up of non-eluting sample components change the selectivity of the column. Introduce washing procedure at regular intervals.
Low sensitivity.	Wrong wavelength/weak chromophore.	Use photodiode array detector, change detection mode (for example to fluorescence, RI or electrochemical etc).
	Broad peaks.	Optimize running conditions (flow rate, temperature) use column with smaller particles, reduce extra column volumes. Use stronger eluent, use gradient elution.
	Sample loss due to non-specific binding.	Use inert HPLC system; use inert HPLC columns, use mobile phase additives to reduce non-specific binding.



Industry Associations

Environmental	256
Food, Flavor, Fragrance	256
Pharmaceutical	256
Forensic	257
Fuels & Petrochemicals	257
General Chemistry	257
Life Sciences	258
Chromatography	258
Mass Spectrometry	258



Association	Website	Country/Region
Australian Institute of Environmental Health	www.aieh.org.au	Australia
Australian Environment Portal	www.environment.gov.au	Australia
Brazilian Institute of Environment and Renewable Natural Resources	www.ibama.gov.br	Brazil
UNEP (United Nations Environment Programme)	www.unep.org	Global
Environment Canada	www.ec.gc.ca	Canada
Environment Institute of Australia and New Zealand	www.eianz.org	Australia
European Environment Agency	www.eea.europa.eu	Europe
European Pesticides Residue Workshop	www.eprw2010.com	Europe
International Association in Environmental and General Chemistry	www.iaec.com	Global
International Dioxin Symposium Website	www.dioxin20XX.org	Global
Ireland Environment Protection Agency	www.epa.ie	Ireland
National Institute for Environmental Studies (NIES)	www.nies.go.jp	Japan
Swedish Environmental Protection Agency	www.swedishepa.se	Sweden
United States Environmental Protection Agency	www.epa.gov	US

Industry Associations | Food, Flavor, Fragrance

Industry Associations



Association	Website	Country/Region
American Dairy Association	www.dairyinfo.com	US
Dairy Industry Association of Australia	www.diaa.asn.au	Australia
European Federation for the Science and Technology of Lipids	www.eurofedlipid.org	EU
Flavor and Extract Manufacturers Association	www.femaflavor.org	US
Fragrance & Flavour Development Centre (FFDC)	www.ffdcindia.org	India
Fragrance Materials Association (FMA)	www.fmafragrance.org	US
Food Technology Association of Australia	www.ftavic.com.au	Australia
International Alliance of Dietary/Food Supplement Associations	www.iadsa.org	Global
International Association of Food Protection	www.foodprotection.org	Global
International Fragrance Association	www.ifraorg.org	Global
International Flavor and Fragrance	www.iff.com	Global
Institute of Food Technologists	www.ift.org	US
Research Institute for Fragrance Materials	www.rifm.org	Global
The American Oil Chemists' Society	www.aocs.org	Global
The European Flavour and Fragrance Association (EFFA)	www.effa.be	EU

Industry Associations | Pharmaceutical



Association	Website	Country/Region
Academy of Pharmaceutical Sciences of Great Britain	www.apsgb.org	UK
American Association of Pharmaceutical Scientists	www.aapspharmaceutica.com	US
American Association of Pharmaceutical Scientists (AAPS)	www.aaps.org	US
Association de Pharmacie Galenique Industrielle (APGI)	www.apgi.org	France
Association of the British Pharmaceutical Industry	www.pharmaceutical-int.com	UK
Australian Pharmaceutical Science Association	www.apsa-online.org	Australia
China Pharmaceutical Industry Association	www.cpia.org.cn	China
European Association of Euro-Pharmaceutical Companies	www.eaepc.org	Europe
European Directorate for the Quality of Medicines & HealthCare	www.edqm.eu	Europe
European Federation of Pharmaceutical Industries and Associations	www.efpia.org	Europe
Federation of Asian Pharmaceutical Association	www.fapa2010-taiwan.com	Asia
International Federation of Pharmaceutical Manufacturers and Associations	www.ifpma.org	Global
International Pharmaceutical Excipients Council (IPEC)	www.ipec.org	Global
International Pharmaceutical Federation	www.fip.org	Global
Royal Pharmaceutical Society of Great Britain	www.rpsgb.org.uk	UK
Pharmaceutical Society of Australia	www.psa.org.au	Australia
Pharmaceutical Research and Manufacturers of America (PhRMA)	www.phrma.org	US
The European Federation for Pharmaceutical Sciences – EUFEPS	www.eufeps.org	Europe
United States Pharmacopeial Convention Inc. (USP)	www.usp.org	US

Association	Website	Country/Region
Academia Iberoamericana de Criminalística y Estudios Forenses	www.aicef.net	Spain
American Society of Crime Laboratory Directors	www.asclcd.org	US
Consortium of Forensic Science Organizations	www.thecfso.org	US
European Network of Forensic Science Institutes	www.enfsi.eu	Europe
National Institute of Forensic Science	www.nifs.com.au	Australia
National Forensic Science Technology Center (NFSTC)	www.nfstc.org	US
The American Academy of Forensic Sciences (AAFS)	www.aafs.org	US
The Australian and New Zealand Forensic Science Society	www.anzffs.org.au	Australasia
The Canadian Society of Forensic Science (CSFS)	www.csfs.ca	Canada
The Indo-Pacific Association of Law, Medicine and Science (INPALMS)	www.inpalms.com	Indo-Pacific
The International Association for Identification (IAI)	www.theiai.org	Global
The International Forensic Summit	www.theforensicsummit.org	Global
The Forensic Science Society	www.forensic-science-society.org.uk	UK
The Society of Forensic Toxicologists	www.soft-tox.org	US



Industry Associations | Fuels & Petrochemicals

Association	Website	Country/Region
Asia Petrochemical Industries Conference	www.apic-online.org	Asia
Association of Petrochemicals Producers in Europe	www.petrochemistry.net	Europe
Canada's Chemical Producers	www.ccpa.ca	Canada
European Biodiesel Board	www.ebb-eu.org	Europe
Gulf Petrochemicals and Chemicals Association (GPCA)	www.gpca.org.ae	Gulf States
Latin American Petrochemical and Chemical Association (APLA)	www.apla.com.ar	Latin America
National Biodiesel Board	www.biodiesel.org	US
National Petrochemical and Refiners Association (NPRA)	www.npradc.org	US
The European Petrochemical Association (EPCA)	www.epca.be	Europe

Industry Associations



Industry Associations | General Chemistry

Association	Website	Country/Region
American Association for Clinical Chemistry (AACC)	www.aacc.org	US
American Chemical Society (ACS)	portal.acs.org	US
American Institute of Chemists (AIC)	www.theaic.org	US
Association of Analytical Community	www.aoac.org	Global
Australian Academy of Science	www.science.org.au	Australia
Chemical Institute of Canada	www.chem-inst-can.org	Canada
Chemical Society of Japan	www.chemistry.or.jp	Japan
Czech Chemical Society	www.csch.cz	Czech Republic
European Chemical Society (ECS)	ecs.chim.ucl.ac.be	Europe
Federation of Australian Scientific and Technological Societies (FASTS)	www.fasts.org	Australia
French Association of Preparative Science	nte-serveur.univ-lyon1.fr	France
German Society for Chemical Engineering, Chemical Technology and Biotechnology	www.dechema.de	Germany
Korean Chemical Society	journal.kcsnet.or.kr	Korea
Royal Society of Chemistry (RSC)	chemistry.rsc.org	Australia
Royal Australian Chemical Institute	www.raci.org.au	Australia
Science Industry Australia	scienceindustry.com.au	Australia
Sociedade Brasileira de Química (SBQ) - Brazilian Chemical Society	www.s bq.org.br	Brazil
South African Chemical Institute	www.saci.co.za	South Africa
Swiss Chemical Society	www.swiss-chem-soc.ch	Switzerland
The Association of Official Analytical Chemists	www.aoac.org	Global
The New Zealand Institute of Chemistry	www.nzic.org.nz	New Zealand
The Society of Chemical Industry (SCI)	www.soci.org	UK





Industry Associations

Association	Website	Country/Region
ABLE	www.ableindia.org	India
AfricaBio	www.africabio.com	South Africa
AgroBIO Mexico	www.agrobiomexico.org.mx	Mexico
All India Biotech Association (AIBA)	www.aibaonline.com	India
Asia Science and Technology Portal	astp.jst.go.jp	Asia
Assobiotec	assobiotec.federchimica.it	Italy
Associação Portuguesa de Bioindústrias (APBIO)	www.apbio.pt	Portugal
Asociación Espanola de Bioempresas (ASEBIO)	www.asebio.com	Spain
Association of German Biotechnology Companies	www.v-b-u.org	Germany
AusBiotech - Australia's Biotechnology Organisation	www.ausbiotech.org/	Australia
Austrian Association of Molecular Life Sciences and Biotechnology	www.oegmbt.at	Austria
Australian Society for Biochemistry and Molecular Biology	www.asbmb.org.au/	Australia
BIA	www.bioindustry.org	UK
BIA Scotland	www.bioindustry.org	Scotland
Belgian Bioindustries Association (BBA)	www.bba-bio.be	Belgium
BIO	www.bio.org	USA
Bioindustry Association of Korea (BAK)	www.koreabio.org	Korea
BIOSINGAPORE	www.biosingapore.org.sg	Singapore
Biotechnology Industry Association	http://bio.org/	US
BIOTECCanada	www.biotech.ca	Canada
China National Center for Biotechnology Development (CNCBD)	www.cncbd.org.cn	China
Confederation of India Industry	cii.in	India
Deutsche Industrievereinigung Biotechnologie (DIB)	www.dib.org	Germany
Development Centre for Biotechnology	www.dcb.org.tw	Taiwan
DuBiotech	www.dubiotech.ae	UAE
European Federation of Biotechnology	www.efb-central.org	Europe
Finnish Bioindustries	www.finbio.net	Finland
Foro Argentino de Biotecnología (FAB)	www.foarbi.org.ar	Argentina
France Biotech	www.france-biotech.org	France
French Association on Biotechnology and Bioindustry (ADEBIO)	www.adebio.org	France
Fundação BIOMINAS	www.biominas.org.br	Brazil
Hong Kong Institute of Biotechnology Ltd	www.hkib.org.hk	Hong Kong
Irish Bioindustry Association	www.ibec.ie	Ireland
Japan Bioindustry Association	www.jba.or.jp	Japan
Malaysian Biotech Corporation (MBC)	www.biotechcorp.com.my	Malaysia
Netherlands' Biotechnology Association (Niaba)	www.niaba.nl	Netherlands
NZBio	www.nzbio.org.nz	New Zealand
Spanish Society on Biotechnology	www.sebiot.org	Spain
Swiss Biotech Association	www.swissbiotechassociation.ch	Switzerland
Thai Society for Biotechnology	www.biotec.or.th	Thailand

Industry Associations | Chromatography

Association	Website	Country/Region
American Society for Testing Materials (ASTM)	www.astm.org	Global
California Separation Science Society (CASSS)	www.casss.org	US
European Society for Separation Sciences (EuSSS)	www-c724.uibk.ac.at/theochem/eusss/	Europe
The Chromatographic Society	www.chromsoc.com	Global

Industry Associations | Mass Spectrometry

Association	Website	Country/Region
British Mass Spectrometry Society	www.bmass.org.uk	UK
International Mass Spectrometry Foundation	www.imss.nl	Global
The American Society for Mass Spectrometry	www.asms.org	USA
The Australian and New Zealand Society for Mass Spectrometry	www.anzsms.org	Australasia
The Mass Spectrometry Society of Japan	www.mssj.jp	Japan



Index

Alphabetical Index	260-266
Part Number Index	267-274
Chromatogram Index	
GC Applications	275-277
HPLC Applications	277

Alphabetical Index

Product		Page
100% Dimethyl Polysiloxane		82, 83-85
100% Dimethyl Polysiloxane in a Sol-Gel Matrix		82, 85-86
14% Cyanopropylphenyl Polysiloxane		82, 96
2 Dimensional GC		184
2 Way Splitter		185, 227
3 Port Splitter		185, 227
3 Way Splitter		185
35% Phenyl Polysilphenylene-siloxane		82, 90-91
4 Port Splitter		185
5% Phenyl / 95% Dimethyl Polysiloxane		82, 86-87
5% Phenyl Polycarborane-siloxane		82, 89
5% Phenyl Polysilphenylene-siloxane		82, 87-88
50% Cyanopropylphenyl Polysiloxane		82, 97
50% Phenyl Polysilphenylene-siloxane		82, 92
70% Cyanopropyl Polysilphenylene-siloxane		82, 92-93
8% Phenyl Polycarborane-siloxane		82, 90
90% Cyanopropyl Polysilphenylene-siloxane		82, 93
A		
AB Sciex Instrument	Electron Multiplier	246-247
AC Control Injector Liner		169
Acrylate Coating of Fused Silica Tubing		230
Activated Charcoal		166
Agilent Instruments	Base Seal	169-170
Agilent Instruments	Electron Multipliers	170, 243
Agilent Instruments	Ferrules	169
Agilent Instruments	FID Flame Jet	194
Agilent Instruments	GC Autosampler Syringes	43, 167
Agilent Instruments	GC Connections	165, 169
Agilent Instruments	GC Inlet Liners	168
Agilent Instruments	GC On-column Syringes	59
Agilent Instruments	GC Supplies Instrument Quick Pick Guide	167-170
Agilent Instruments	O-rings	169
Agilent Instruments	Septa	167-168
Agilent Instruments	SilTite™ Fingertite Ferrules	170
Altex	LC Manual Syringes	48, 49
Amersham Instrument	Electron Multiplier	243
Analytical Columns	HPLC	208
Antek	FID Flame Jet	195
ATAS Optic Injectors Instrument	GC Inlet Liners	180
Autosampler Syringes	GC	43-47, 167-180
Autosampler Syringes	GC Supplies Instrument Quick Pick Guide	167-177
Autosampler Syringes	LC	50-52
Auto-Sep T™ Septa		150
Auto-Sep™ Septa		150
B		
BackFlush	SilFlow™ Splitting	185
Barrel Internal Diameter	Syringe	32
Base Seals Agilent Instrument		169, 170
Beckman	LC Manual Syringes	48, 49
BioRad Instrument	Electron Multiplier	243
BP1	GC Column	83-84
BP1 PONA	GC Column	84
BP10 (1701)	GC Column	96
BP20 (WAX)	GC Column	94-95
BP21 (FFAP)	GC Column	95-96
BP225	GC Column	97
BP5	GC Column	86-87
BP624	GC Column	98
BPX1	GC Column	84-85

Product		Page
BPX35	GC Column	90-91
BPX5	GC Column	87-88
BPX50	GC Column	92
BPX608	GC Column	91
BPX70	GC Column	92-93
BPX90	GC Column	93
BPX-VOLATILES	GC Column	97
Brass Nuts		164
Bulk Head Unions		161-164
C		
Calibration - Syringes	Certificate of Conformance	34
Calibration - Syringes	eVol®	22
Calibration - Syringes	Syringe Validation and Calibration	34
CAMECA Instrument	Electron Multiplier	243
Capability, SGE		2
Capillary Coating Reservoir		193
Capillary Columns	HPLC	205
Capillary Cutting Tools	GC	195
Capillary Electrophoresis Tubing		233
Capillary GC Columns		74-98, 149, 246-247
Capillary In-line Filters		222, 226
Capillary Trap columns		205
Capillary Washing Reservoir		193
Certified GC Inlet Liners		157
Chromatography Associations		258
Cleaning	Syringes	30
Cold Traps		192
Column Design	HPLC	198-199
Column Replacement Frits	HPLC	224
Column Selection Tree	HPLC	203
Column Splitting	GC	184
Columns GC Capillary		74-98
Comstock Instrument	Electron Multiplier	243-244
Conformance - Syringe Certificate of		34
Connections	GC Connections - Agilent	169
Connections		149
Connections for HPLC		223
ConnectTite	GC Inlet Liners	152, 154, 168, 171, 173, 175, 176, 179, 250
Cryogenic Cold Trap		192
CS Septa		150
CTC Analytics	GC - Autosampler Syringes	44
CTC Analytics	LC - Autosampler Syringes	51
CTC PAL-XT	GC - Autosampler Syringes	45
CTC PAL-XT	LC - Autosampler Syringes	51
Customer Story		8-14
Customized Solutions		3
Cyanopropylphenyl Polysiloxane		82, 97-98
CYDEX-B™	GC Column	98
D		
Detector Splitting		184
Detector Unions	HPLC	225
Diamond Syringe Technology		16
Diluter/Dispenser Syringes		40, 54
Direct Injection Technique		154
Discrete Dynode Technology		241
Distributors - Authorized SGE		3
Double Taper Inlet Liner		153, 168, 178
E		
EasyLok™ Fittings		223
EC Septa		150
Electron Multipliers	AB Sciex Instrument	242-243
Electron Multipliers	Agilent Instrument	170, 242-244
Electron Multipliers	Amersham Instrument	243

Product		Page
Electron Multipliers	BioRad Instrument	243
Electron Multipliers	CAMECA Instrument	243
Electron Multipliers	Comstock Instrument	243- 244
Electron Multipliers	ETP Electron Multipliers	149, 240
Electron Multipliers	GBC Instrument	242-244
Electron Multipliers	GC-MS	242
Electron Multipliers	How Do They Work	240-241
Electron Multipliers	ICP-MS	242
Electron Multipliers	JEOL Instrument	242-244
Electron Multipliers	KORE Technology Instrument	244
Electron Multipliers	Kratos Instrument	243-244
Electron Multipliers	LC-MS	242
Electron Multipliers	Magnetic Sector	243
Electron Multipliers	Nu Instrument	243-244
Electron Multipliers	PerkinElmer Instrument	172, 242, 244
Electron Multipliers	Selection by Instrument	243-244
Electron Multipliers	Selection by Technique	242-243
Electron Multipliers	SENSAR/LARSON-DAVIS Instrument	243-244
Electron Multipliers	Shimadzu Instrument	174, 242, 244
Electron Multipliers	Thermo Scientific Instrument	177, 242-244
Electron Multipliers	TOF-MS	243
Electron Multipliers	Varian/Bruker Instrument	180, 242, 244
Electron Multipliers		149, 240-244
Enduro Blue Septa		150
Environmental	Analyses	8
Environmental	Associations	256
eVol® - Digitally Controlled Analytical Syringe		19, 21-24
eVol® - Digitally Controlled Analytical Syringe	Accessories	24
eVol® - Digitally Controlled Analytical Syringe	Battery	24
eVol® - Digitally Controlled Analytical Syringe	Charger	24
eVol® - Digitally Controlled Analytical Syringe	Charging Stand	24
eVol® - Digitally Controlled Analytical Syringe	eVol® XCHANGE® Syringes	24
eVol® - Digitally Controlled Analytical Syringe	MEPS™	23-24, 57, 219
eVol® - Digitally Controlled Analytical Syringe	Needles	24
eVol® - Digitally Controlled Analytical Syringe	NMR Edition	23-24
eVol® - Digitally Controlled Analytical Syringe	Stand	24
Exsil™ Guard Cartridges		226
Extended Nuts		161-164
F		
Ferrules		149, 158-160
Ferrules	Agilent Instrument	169-170
Ferrules	Blank	160-161
Ferrules	Graphite	158
Ferrules	Graphite/Vespel®	158
Ferrules	Kel-F®	223
Ferrules	PEEK™	223
Ferrules	PerkinElmer Instrument	171-172
Ferrules	Reducing	160-161
Ferrules	Replacement	163
Ferrules	Shimadzu Instrument	174
Ferrules	SilTite™ Metal	158
Ferrules	Straight	160-161
Ferrules	Thermo Scientific Instrument	176
Ferrules	Two, Three Hole	160-161

Product		Page
Ferrules	Varian/Bruker Instrument	179-180
FID		194
FID Flame Jet	Agilent Instrument	194
FID Flame Jet	Varian/Bruker and Antek Instrument	194
FID Flame Jet		194
Filters/Purifiers	Activated Charcoal	166
Filters/Purifiers	Advanced Gas Filter System	165
Filters/Purifiers	Gas Purifier Kit	165
Filters/Purifiers	Gas Purifiers	165
Filters/Purifiers	Hydrocarbon Traps	166
Filters/Purifiers	Indicating Molecular Sieve	166
Filters/Purifiers	Indicating Oxygen Traps	166
Filters/Purifiers	Moisture Purifier	166
Filters/Purifiers	Moisture Trap	166
Filters/Purifiers	Oxygen Scrubbers	166
Filters/Purifiers	Oxygen Traps	166
Fingertight Fittings	HPLC	225
Fittings		149
Fixed Inlet Splitter for Capillary Columns		186
Fixed Needle Syringes	Agilent Instrument GC Autosampler Syringes	167
Fixed Needle Syringes	PerkinElmer Instrument GC Autosampler Syringes	170
Fixed Needle Syringes	Shimadzu Instrument GC Autosampler Syringes	172
Fixed Needle Syringes	Thermo Scientific Instrument GC Autosampler Syringes	175
Fixed Needle Syringes	Varian/Bruker Instrument GC Autosampler Syringes	177
Fixed Outlet Splitter for Capillary Columns		186-187
Flame Ionization Detector		194
Flow Control Valve		190 - 191
Flow Meter		195
Fluidic Logic		182-183
FocusLiner™		152, 155, 168, 171, 173, 175, 178-180, 246
Food, Flavors & Fragrance	Analyses	9
Food, Flavors & Fragrance	Associations	256
Forensic	Analyses	12
Forensic	Associations	257
Fragrance Detection		194
Fuels & Petrochemical	Analyses	10
Fuels & Petrochemical	Associations	257
Fused Silica Tubing		230-233
G		
Gas and Vapor Field Sampler		195
Gas Flow Calculator App		187
Gas Flow, Effect of Temperature		188
Gas Purifiers		165
Gas Sealing Gland Syringes		61
Gas Tight	See PTFE Tipped Plunger Syringes	
GBC Instrument	Electron Multiplier	242-244
GC	Column Performance Formulae	249
GC	Detector and Injector Temperatures	249
GC	Detector Selection	246

Product		Page
GC	Injection Conditions	246
GC	Inlet Liner Enhancements	19
GC	Oven Temperature	249
GC	Parameter Optimization	249
GC	Split Ratio	249
GC Autosampler Syringes		43-47
GC Autosampler Syringes	Agilent Instrument	43
GC Autosampler Syringes	Bruker / Varian Instrument	47
GC Autosampler Syringes	CTC Analytics Instrument	44
GC Autosampler Syringes	CTC PAL-XT Instrument	45
GC Autosampler Syringes	PerkinElmer Instrument	46
GC Autosampler Syringes	Shimadzu Instrument	45
GC Autosampler Syringes	Thermo Scientific Instrument	46
GC Capillary Column	Dimensions	80-82, 246-247
GC Capillary Column	Phase Selection	76-80, 247
GC Capillary Columns		74-98, 149, 246-247
GC Carrier Gas & Velocity		247-248
GC Connections		149
GC Inlet Liners		19, 149, 151-158, 168-169, 171, 173, 175-176, 178-179
GC Inlet Liners	AC Control Injector Liner	169
GC Inlet Liners	Agilent Instrument	168-169
GC Inlet Liners	ATAS Optic Injectors Instrument	180
GC Inlet Liners	Certified Liners	157
GC Inlet Liners	ConneCTite	152, 154, 168, 171, 173, 175, 176, 179, 246
GC Inlet Liners	Deactivation	157
GC Inlet Liners	Direct Injection	154
GC Inlet Liners	Double Taper Liner	153, 168, 178
GC Inlet Liners	FocusLiner™	152, 155, 168, 171, 173, 175, 178, 180, 246
GC Inlet Liners	Gerstel CIS 4 Injection Liner	169
GC Inlet Liners	Gooseneck	152, 168, 171, 173, 178
GC Inlet Liners	Injection Technique	154
GC Inlet Liners	Inlet Liner Packing Materials	154-155
GC Inlet Liners	Inlet Liner Volume	156
GC Inlet Liners	Inlet Operating Parameters	154-156
GC Inlet Liners	Liner Geometry	152
GC Inlet Liners	LVI Inlet Liners	153, 169, 171, 176, 179
GC Inlet Liners	MS Certified Liners	157
GC Inlet Liners	O-rings - Agilent Instrument	169
GC Inlet Liners	O-rings - PerkinElmer Instrument	171
GC Inlet Liners	O-rings - Shimadzu Instrument	173
GC Inlet Liners	O-rings - Varian/ Bruker Instrument	179
GC Inlet Liners	Packed Column Liner	168

Product		Page
GC Inlet Liners	PerkinElmer Instrument	171
GC Inlet Liners	PTV Injection	154
GC Inlet Liners	PTV Inlet Liners	153-154, 171, 173, 176
GC Inlet Liners	Selection	151
GC Inlet Liners	Selection Tool	152
GC Inlet Liners	Shimadzu Instrument	173
GC Inlet Liners	Split Injection	154
GC Inlet Liners	Splitless Injection	154
GC Inlet Liners	Straight Liner	153, 168, 171, 173, 175, 178, 179, 180
GC Inlet Liners	Taper FocusLiner™	152
GC Inlet Liners	Taper Liner	152, 172
GC Inlet Liners	Thermo Scientific Instrument	175-176
GC Inlet Liners	Varian/Bruker Instrument	178-179
GC Manual Syringes		35-40
GC On-column Syringes		58-59
GC Splitters	3 Port Splitter	185
GC Splitters	4 Port Splitter	185
GC Splitters	2 Way Splitter	185
GC Splitters	3 Way Splitter	185
GC Supplies	Quick Pick Guide by Instrument	167-180
GC Syringes		35-39, 43-47
GC x GC		184
GC-MS Column Changeover		195
General Chemistry	Analyses	11
General Chemistry	Associations	257
General Purpose Syringes		35-40
Gerstel CIS 4 Injection Liner		169
Glass Lined Mini Unions		161-164
Glass Lined Tubing (GLT™)		236-237
Glass Surface Technology		16
GLT™ Unions		161-164
Graphite Ferrules		158-161
Graphite/Vespel® Ferrules		158-161
Guard Cartridge Systems		226
Guard columns - HPLC		206
H		
Hamilton	Pump Replacement Syringes	55
Hamilton	Syringe Cross Reference Guide	70-72
Headspace/Soil Gas Syringes		62
Hexnut™ Fittings		223
High Pressure Syringes		62
Hitachi Instrument Syringes		50
How to Order		3
HPLC	Accessory Kits	226
HPLC	Analytical Columns	204
HPLC	Capillary Columns	205
HPLC	Capillary Guard Columns	206
HPLC	Capillary In-line Filters	222
HPLC	Capillary Trap Columns	205
HPLC	Column Couplers	225
HPLC	Column Design	198-299
HPLC	Column Replacement Frits	224
HPLC	Column Selection Tree	203
HPLC	Detector Unions	225
HPLC	Ferrules	225
HPLC	Fingertight Fittings	225
HPLC	Fittings	223-225
HPLC	Guard Cartridge Systems	226
HPLC	Guard Columns	206

Product		Page	
HPLC	Injection Loop, PEEKsil™	223	
HPLC	In-line Filters	222	
HPLC	MicroFlow Meter	228	
HPLC	PEEKsil™ Tubing kits	222	
HPLC	PEEK™ Lined Columns	198-199	
HPLC	Pore Size	198-201	
HPLC	ProteCol™	198-199, 202-206, 224	
HPLC	Renkin Model and Pore Size	200	
HPLC	ReproSil® Trap Columns	205	
HPLC	Reversed Phase	198-199	
HPLC	SilFlow™	227	
HPLC	Solvent Filter	227	
HPLC	Splitter	227	
HPLC	Tips for Large Molecules	203	
HPLC	Tips for Small Molecules	202	
HPLC	Unions	224-225	
HT Septa		150	
HT5	GC Column	89	
HT8	GC Column	90	
Hydrocarbon Traps		166	
I			
	Increasing Column Sensitivity	192	
	Indicating Molecular Sieve	166	
	Indicating Oxygen Traps	166	
	Injection Loops	223	
	Injection Technique	154	
	Injector to Detector	148	
	Inlet Liner Enhancements	19	
	Inlet Liner Packing Materials	154-155	
	Inlet Liner Volume	156	
	Inlet Operating Parameters	155-156	
	In-line Filters	222	
	Instrument Syringes	54	
	Instrument Syringes	1-100 mL PTFE Tipped Plunger Syringes	54-56
	Instrument Syringes	Hamilton Pump Replacement Syringes	55
	Instrument Syringes	Shimadzu Total Organic Carbon Analyzer TOC5000	56
	Instrument Syringes	Zymark	56
J			
	JEOL Instrument	Electron Multiplier	242, 244
	Jumbo Syringes	0.5 L - 2 L	60
	Jumbo Syringes	Accessories	60
K			
	Kel-F® Ferrules		223
	KORE Technology Instrument	Electron Multiplier	244
	Kratos Instrument	Electron Multiplier	243-244
L			
	Large Volume Syringes	See Jumbo Syringes	
	LC Autosampler Syringes		50-52
	LC Autosampler Syringes	CTC Analytics -Fixed and Removable	51
	LC Autosampler Syringes	CTC PAL-XT	51
	LC Autosampler Syringes	Hitachi Instruments	50
	LC Autosampler Syringes	PerkinElmer Instruments	50
	LC Autosampler Syringes	Spark Holland Instruments	52
	LC Autosampler Syringes	Thermo Scientific Instruments	52
	LC Autosampler Syringes	Waters Instruments	52
	LC Autosampler Syringes	WISP Dipper Needle	52
	LC Manual Syringes	Fixed and Removable	48,49
	LC Manual Syringes - Fixed and Removable	Beckman/Altex Instrument	48,49
	LC Manual Syringes - Fixed and Removable	Rheodyne Instrument	48,49

Product		Page	
	LC Manual Syringes - Fixed and Removable	SSI Instruments	48,49
	LC Manual Syringes - Fixed and Removable	Valco Valves Instrument	48,49
	LC Pump Priming Syringes		53
	LC Syringes		48-53
	Life Sciences	Analyses	13
	Life Sciences	Associations	258
	Liner Geometry		152
	Liner Selection		151
	Liner Selection Tool		152
	Liquid CO2 Cryogenic Cold Trap		194
	Liquid Liquid Extraction		218
	Luer Lock / Luer Tip		26, 39, 40, 41, 54, 55, 56, 67, 68
	LVI Inlet Liners		153, 169, 171, 176, 179
M			
	Manual Syringes		35-40
	Mass Spectrometry		240-244
	Mass Spectrometry	Associations	258
	MEPS™ (Micro Extraction by Packed Sorbent)		23-24,57 148, 218-221
	MEPS™	Automation	219
	MEPS™	Barrel Insert and Needle Assembly Options	221
	MEPS™	How to Use	219
	MEPS™	Stationary Phases	218, 221
	MEPS™	Agilent Instrument	57, 221
	MEPS™	Applications/ Publications	220
	MEPS™	CTC Analytics Instrument	57, 221
	MEPS™	eVol® MEPS™	23-24,57, 219, 221
	MEPS™	Manual and Autosampler Syringes	57, 221
	MEPS™	Sorbents	218, 221
	Metal Deactivation		182-183
	Method Development	GC	246-249
	Method Development	HPLC	252
	Micro Extraction by Packed Sorbent (MEPS™)		23-24,57 148, 218-221
	Microchannel Devices		20,182-184, 231
	Micro-control Valves		188-191
	MicroFlow Meter		228
	Mini Union Nuts		164
	Moisture Purifier		165
	Moisture Trap		165
	Molecular Sieve		166
	MS Certified GC Inlet Liners		157
N			
	Nanovolume Syringes		35
	Nanovolume Syringes	NanoVolume Replacement Plunger-in-needle kits	65
	Needle	10 µL	66
	Needle	1-2.5 mL	67
	Needle	25-500 µL	67
	Needle	5 µL	66
	Needle	5 µL eVol®	24
	Needle	50 µL eVol®	67
	Needle	500 µL eVol®	67
	Needle	5-10 mL	67
	Needle	Care	31
	Needle	Cleaning Kit	64
	Needle	Luer lock	67
	Needle	Replacement	66-67

Product		Page
Needle	Selection	27-28
Needle	Valve Needles	41
Needle	Tip Styles	28
Nu Instrument	Electron Multiplier	243-244
Nucleosil ODS Guard Cartridges		226
Nuts		161-165
Nuts	Brass	164
Nuts	Extended	161-164
Nuts	Mini Union	164-165
Nuts	Replacement	163-164
Nuts	SilTite™ (replacement)	165
Nuts	Stainless Steel	164-165
O		
On/off Valve	Micro-control	189 - 190
On/off Valve	Pneumatic	189
On-column GC Syringes	Instrument Specific	59
On-column GC Syringes		58-59
Ordering Information		3
O-rings		169, 171, 173, 179
Oxygen Scrubbers		166
Oxygen Traps		166
P		
Packed Column Liner		168, 171
PEEKsil™ Tubing		234-235
PEEKsil™ Tubing Kits		222
PEEK™ Ferrules		223, 225
PEEK™ Lined HPLC Columns		198-199
PEEK™ Unions for HPLC		229
PerkinElmer Instrument	Electron Multipliers	172, 242, 244
PerkinElmer Instrument	Ferrules	171-172
PerkinElmer Instrument	GC Autosampler Syringes	46, 170
PerkinElmer Instrument	GC Inlet Liners	171
PerkinElmer Instrument	GC On-column Syringes	59
PerkinElmer Instrument	LC Autosampler Syringes	50
PerkinElmer Instrument	O-rings	171
PerkinElmer Instrument	Septa	170
PerkinElmer Instrument	SilTite™ FingerTite Ferrules	172
Permethyated Beta-Cyclodextrin (Chiral)		82, 98
Pharmaceutical	Analyses	13-14
Pharmaceutical	Associations	256
Plunger	Care	30
Plunger	PTFE	29
Plunger	Replacements - Listed by Syringe Part Number	68-69
Plunger	Selection	29
Plunger Tips		16, 29
Plunger-in-needle		29, 35, 65
Plunger-in-needle	NanoVolume	35, 65
Pneumatic Valve	On/off	189
Polyethylene Glycol		82, 94-95
Polyethylene Glycol (PEG)	TPA Treated	82, 95-96
Polyethylene Glycol (PEG) in a Sol-Gel Matrix		82, 94
Polyimide Coating of Fused Silica Tubing		230
Pore Size of HPLC Packings		198
ProteCol™ HPLC Columns		204-206
PTFE Tipped Plunger Syringes		29, 39-40, 54
PTFE Tipped Plunger Syringes	1 - 100 mL	40, 54
PTFE Tipped Plunger Syringes	10 - 500 µL	39
PTV Injection		154
PTV Inlet Liners		153-154, 171, 176
Purifier		165, 166
Q		
Quick Pick Guide, GC Supplies by Instrument		167-180
R		
Rack	Syringes	63
Reducing Ferrule		160-161

Product		Page
Reducing Unions		161-163
Removable Needle		27
Removable Needle Syringes	Agilent Instrument	167
Removable Needle Syringes	PerkinElmer Instrument	170
Removable Needle Syringes	Shimadzu Autosampler	172
Removable Needle Syringes	Thermo Scientific Instrument	175
Removable Needle Syringes	Varian/Bruker Instrument	177
Renkin Model		204
Repeating Adaptor RAX		35, 37, 38, 48, 63
Replacement Ferrules for Unions		163-164
Replacement Nuts		163-164
Replacement Parts	1 - 2.5 mL - needle	67
Replacement Parts	10 µL - needle	66
Replacement Parts	25 - 500 µL - needle	67
Replacement Parts	5 - 10 mL - needle	67
Replacement Parts	5 µL - needle	66
Replacement Parts	5 µL eVol®	24
Replacement Parts	50 µL eVol® - needle	67
Replacement Parts	500 µL eVol® - needle	67
Replacement Parts	Autosampler - Plunger-in-needle Repair Kits	65
Replacement Parts	Hamilton Syringe Cross Reference	70-72
Replacement Parts	Luer lock - needle	67
Replacement Parts	Needles	66-67
Replacement Parts	Plungers - Listed by Syringe Part Number	68-69
Replacement Parts	Autosampler - NanoVolume Syringe Plunger and Needle Kits	65
Replacement Parts	Syringe Components	68
Replacement Parts	Syringes	65-69
ReproSil® Trap columns		205
Retention Gap Kit		195
Reversed Phase HPLC		198
Rheodyne	LC Manual Syringes	48, 49
S		
Sample Preparation Methods Comparison		218
Seal Tight™ Syringe Valves		42
Sealing Rings	General	160-161
Sealing Rings	Agilent Instrument	169
Sealing Rings	Shimadzu Instrument	173
Sealing Rings	Thermo Scientific Instrument	176
Sealing Rings	Varian/Bruker Instrument	179
SENSAR/LARSON-DAVIS Instrument	Electron Multiplier	243-244
Septa		148, 150-151, 167-168, 170, 172, 175, 177-178
Septa	Agilent Instrument	167-168
Septa	Auto-Sep T™	150-151
Septa	Auto-Sep™	150-151
Septa	CS Septa	150-151
Septa	EC Septa	150-151
Septa	Enduro Blue	150-151
Septa	HT Septa	150-151
Septa	PerkinElmer Instrument	170
Septa	Shimadzu Instrument	172
Septa	TCS Septa	150-151
Septa	Thermo Scientific Instrument	175
Septa	Varian/Bruker Instrument	177-178

Product		Page
Shimadzu Instrument	Electron Multipliers	174, 242, 244
Shimadzu Instrument	Ferrules	174
Shimadzu Instrument	GC Autosampler Syringes	45, 172
Shimadzu Instrument	GC Inlet Liners	173
Shimadzu Instrument	O-rings	173
Shimadzu Instrument	Sealing Rings	173
Shimadzu Instrument	Septa	172
Shimadzu Instrument	SilTite™ FingerTite Ferrules	174
Shimadzu Instruments	GC On-column Syringes	59
Shimadzu Instruments	Replacement SilTite™ Nuts	174
Shimadzu Total Organic Carbon Analyzer TOC5000	Syringes	56
Short Ferrule Blank (no hole) 1/16"		160
SilFlow™		20, 182-185, 231
SilFlow™ for HPLC		227
SilFlow™ Splitters		20, 185
SilTite™ FingerTite Ferrules	Varian/Bruker Instrument	180
SilTite™ FingerTite Ferrules		20, 159, 170, 172, 174, 176, 180
SilTite™ FingerTite Ferrules	Agilent Instrument	170
SilTite™ FingerTite Ferrules	PerkinElmer Instrument	172
SilTite™ FingerTite Ferrules	Shimadzu Instrument	174
SilTite™ FingerTite Ferrules	Thermo Scientific Instrument	176
SilTite™ Metal Ferrules		158
SilTite™ Mini Unions		161-162, 164
SilTite™ Nuts (replacement)		165
Soap Bubble Flow Meter		195
Sol-Gel	GC Column	82, 85-86, 99
SolGel-1ms™	GC Column	85-86
SolGel-Wax™	GC Column	94
Solid Phase Extraction		218
Solids Syringes for Pyrojector II™		198
Solvent Filter		227
Spark Holland Instrument	HPLC Syringes	52
Special Purpose Syringes	eVol® MEPS™	57
Special Purpose Syringes	Gas Sealing Gland	61
Special Purpose Syringes	Headspace/Soil Gas	62
Special Purpose Syringes	High Pressure	62
Special Purpose Syringes	Jumbo Syringe Accessories	60
Special Purpose Syringes	Jumbo Syringes - 0.5 L - 2 L	60
Special Purpose Syringes	MEPS™	57
Special Purpose Syringes	On-column GC - General	59
Special Purpose Syringes	On-column GC - Instrument Specific	59
Special Purpose Syringes		57-62
Split Injection		154
Split Vent Trap		166
Splitless Injection		154
Splitters		185-186
Splitters	Detector Splitting	184
Splitters	Fixed Inlet Splitter for Capillary Columns	186
Splitters	Fixed Outlet Splitter for Capillary Columns	186-187
Splitters	SilFlow™ Splitters	185
Splitters	Splitting - Backflush	185
Splitters	Splitting - One Column to Two Detectors	185

Product		Page
Splitters	Splitting - One Injection to Two Capillary Columns	185
Splitters	Splitting - Pre Column with Split to Analytical Column	185
Splitters	Variable Outlet Splitter for Capillary Columns	187
Splitters for HPLC		223
Splitters, Connection Systems		182-183
Splitting	BackFlush	185
Splitting	One Column to Two Detectors	185
Splitting	One Injection to Two Capillary Columns	185
Splitting	Pre-column with Split to Analytical Column	185
SSI Instruments	LC Manual Syringes	48, 49
Stainless Steel Nuts		164-165
Stainless Steel Tubing		238
Stainless Steel Unions		161-164
Straight Ferrules		160-161
Straight GC Inlet Liner		153, 168, 171, 173, 175, 178-180
Straight Through Unions		161-164
Styilet Wires		64
Syringe	Care	30
Syringe	Cleaning	30-31
Syringe	Maintenance	30
Syringe	Selection	26-29
Syringe	Temperature Specifications	30
Syringe	Use	30, 31
Syringe	Volume Color Coding	16
Syringe Accessories	Heated Syringe Cleaner	64
Syringe Accessories	Needle Cleaning Kit	64
Syringe Accessories	Repeating Adaptor (RAX)	63
Syringe Accessories	Styilet Wires	64
Syringe Accessories	Syringe Racks	63
Syringe Accessories		63-64
Syringe Technical Information	Syringe Barrel ID	32
Syringe Technical Information	Syringe Structure	32
Syringe Technical Information	Syringe Troubleshooting	33
Syringe Technical Information		26-33
Syringe Temperature Specifications		30
Syringe Valves		40-42
Syringe Valves	Needles	41
Syringe Valves	Seal Tight™ Valves	42
Syringes		25-72, 148
Syringes	0.5 - 5 µL Syringes	35
Syringes	10-500 µL PTFE Tipped Plunger Syringes	39
Syringes	1-100 mL PTFE Tipped Plunger Syringes	40, 54
Syringes	25-500 µL Metal Plunger	38
Syringes	5-10 µL Metal Plunger Syringes	36-37
Syringes	Autosampler	26, 43-47, 50-52
Syringes	Autosampler - GC	26, 43-47
Syringes	Autosampler - LC	26, 50-52
Syringes	Custom Needles and Syringes	28
Syringes	eVol®	24
Syringes	Gas Sealing Gland	61
Syringes	Guided Plunger Syringes	37
Syringes	Headspace / Soil Gas	62

Product		Page
Syringes	High Pressure	29, 62
Syringes	Instrument	26, 54-56
Syringes	Jumbo	29, 60
Syringes	Manual	26, 35-40
Syringes	Nanovolume Syringes	26, 29-30, 35, 65, 68
Syringes	On-column	39, 58
Syringes	Repeating Adaptor	35, 37, 38, 48, 63
Syringes	Special Purpose Syringes	57-62
Syringes	Superflex Syringes	36
T		
Taper FocusLiner™		152
Taper Liner		152, 172
TCS Septa		150-151
Termination - Syringe		26
Terry-Tool Tubing Cutter		238
Thermo Scientific Instrument	Electron Multiplier	177, 244
Thermo Scientific Instrument	Ferrules	176
Thermo Scientific Instrument	GC Autosampler Syringes	46, 175
Thermo Scientific Instrument	GC Inlet Liners	175-176
Thermo Scientific Instrument	LC Autosampler Syringes	52
Thermo Scientific Instrument	Sealing Rings	176
Thermo Scientific Instrument	Septa	175
Thermo Scientific Instrument	SilTite™ FingerTite Ferrules	176
Tips for Large Molecule Analysis in HPLC		203
Tips for Small Molecules in HPLC Analysis		202
Troubleshooting	GC	250-251
Troubleshooting	HPLC	253-254
Troubleshooting	Syringes	33
Tubing	Capillary Electrophoresis Tubing	233
Tubing	Fused Silica Tubing	230-233
Tubing	Glass Lined Tubing (GLT™)	236-237
Tubing	PEEKsil™ Tubing	234-235
Tubing	Polyimide Coating of Fused Silica Tubing	230
Tubing	Stainless Steel	238
Tubing Cutter		238
U		
Unions		149, 161-164
Unions	Bulk Head Unions	161-164
Unions	GLT™ Unions	161-164
Unions	Reducing Unions	161-164
Unions	SilTite™ Mini Unions	161-164
Unions	Stainless Steel Unions	161-164
Unions	Straight Through Unions	161-164
Unions	Union Cross	161-164
Unions	Union Tees	161-164
Unions for HPLC		224-225
V		
Valco		48-49, 223, 225
Validation	Syringe	34
Valves		188-191
Valves	Flow Control Valve	190 - 191
Valves	Micro- control Valves	188
Valves	On/off Valve	189 - 190
Valves	Pneumatic	188-189
Valves	Replacement Parts	191
Valves for Syringes		40-42
Valves for Syringes	Seal Tight™	42
Van Deemter Equation		248
Variable Outlet Splitter for Capillary Columns		187
Varian Instrument	GC Autosampler Syringes	47, 177
Varian/Bruker Instrument	Ferrules	179-180

Product		Page
Varian/Bruker Instrument	FID Flame Jet	195
Varian/Bruker Instrument	GC Inlet Liners	179-180
Varian/Bruker Instrument	O-Rings	179
Varian/Bruker Instrument	Sealing Rings	179
Varian/Bruker Instrument	Septa	177 -178
Varian/Bruker Instrument	SilTite™ FingerTite Ferrules	180
Varian/Bruker Instrument	Electron Multipliers	180, 248
Varian/Bruker Instrument	GC On-column Syringes	59
VG Elemental Instrument	Electron Multiplier	244
Viscosity Effect	Effect of Viscosity on Flow	188
Viscosity Effect	Temperature and Flow	188
W		
Waters Instruments	LC Autosampler Syringes	52
What's New		15-20
WISP Dipper Needle		52
X		
XCHANGE®		18
XCHANGE®	CTC PAL-XT - GC Autosampler Syringes	45
XCHANGE®	CTC PAL-XT - LC Autosampler Syringes	51
XCHANGE® Syringe Rack		63

Part Number Index

Part No.	Page
0003..	
000300	35, 65
000301	35, 65
000303	35, 65
000310	35, 65
000311	35, 65
000350	35
000353	35
000355	35
000372	59, 65
000376	59, 65
000380	59, 65
0004..	
000400	43, 65, 71, 167
000410	43, 65, 71, 128, 138, 167
000415	43, 65, 167
000440	45, 65, 172
000445	45, 65, 172
000450	172
000475	46, 65, 170
000478	46, 65, 170
000490	44, 46, 65, 175
000492	44, 46, 65, 175
0005..	
000500	35, 65
000501	35, 65
000505	35, 65
000506	35, 65
000510	35, 65
000550	35
000553	35
000570	35, 65, 70
0006..	
000610	43, 65, 70, 167
000655	47, 65, 177
0007..	
000790	44, 46, 65
0008..	
000800	35, 65
000801	35, 65
000802	35, 65, 72
000803	35, 65, 72
000804	35, 65
000805	35
001...	
001000	36, 71
001002	36
001050	36, 72
001090	37
001100	36
001105	36, 175
001150	36
001301	48
001310	49
001400	37, 72
001450	37, 72
001455	37
001490	37
001495	37
001552	59
001554	59
001560	59
001585	59
001587	59
001700	44
001800	43, 72, 167
001804	43, 72
001805	43, 72, 167
001810	43, 72, 127, 167
001814	43, 70, 72
001815	43, 72, 167

Part No.	Page
001821	43, 70, 72, 167
001822	43, 70, 72
001825	43, 70, 72, 167
001839	36
001953	46, 72, 170
001954	46, 72, 170
001955	46, 68, 170
001957	46, 68, 170
001981	44, 46
001982	44, 72
001984	44
001987	45, 172
001988	45, 172
0020..	
002000	34, 36, 70
002003	36, 70
002005	36
002007	36
002030	36, 70
002033	36
002035	36
002040	37
002050	36, 70
002055	36
002080	36
002090	37
0021..	
002100	36
002101	36
002105	36
002108	36
002130	36
002133	36
002135	36
002150	36
002180	36
0022..	
002200	39, 68, 70
002202	39
002208	39, 68
002250	39, 68, 70
002252	39
0023..	
002300	48
002301	48, 70
002310	49
002313	49, 68, 70
002315	48
002330	48
002335	48, 68
002345	48
002350	49
0024..	
002400	37, 70, 71
002450	37, 70, 71
002455	39, 68, 71
002490	37
002493	37
0025..	
002500	39, 59, 68
002520	59, 71
0027..	
002700	44, 72
002705	44, 72
002710	51, 72
002715	51, 68, 72
0028..	
002800	43, 70, 167
002804	43, 70
002805	43, 70, 167
002810	43, 70, 167
002812	43, 68, 70, 167

Part No.	Page
002813	43, 70
002814	43, 70
002815	43, 70, 167
002817	43, 68, 70, 167
002818	43, 68, 70, 167
002820	43
002821	43, 70, 167
002822	43, 70
002824	43
002825	43, 70, 167
002826	43, 68, 70, 167
002827	43, 70
002829	43, 68, 70, 167
002830	43
002831	43
002838	43
002839	36
002845	43
002885	45
002897	45, 172
002898	45, 72, 172
0029..	
002902	45, 68, 172
002923	47, 68, 177
002924	47, 68, 72, 177
002950	47, 177
002965	44, 68
002967	46, 175
002971	44, 46
002972	44, 46
002974	46
002976	44
002977	44, 68
002980	46, 175
002981	44, 46, 47, 72, 175, 177
002982	44, 46, 47, 175, 177
002983	44
002984	44, 46, 175
002985	44, 68
002986	46
002987	44, 46, 68, 175
002989	46, 175
002991	68
002992	46, 72, 175
002993	46, 175
002997	46
003...	
003000	38, 70
003050	38
003090	38
003200	39, 68, 70
003250	39, 68, 70
003300	48, 70
003310	49
003312	49, 68, 70
003320	48
003600	61
003610	61
003665	43
003668	43, 68
003700	44, 68, 72
003715	51, 68, 72
003980	44
003984	51
003985	51, 68
003987	44, 68
003988	44, 69
003989	44, 68
003990	52, 69, 70
003995	55, 69, 70
004...	

Part No.	Page
004000	38, 70
004050	38, 70
004090	38
004200	39, 69, 71
004229	39, 69-71
004230	39, 69, 71
004232	55, 69
004250	39, 69, 71
004279	41, 69, 71
004300	48, 70
004310	49
004312	49, 69, 71
004320	48
004600	61
004665	43
004668	43, 69
004670	46, 170
004682	45
004810	51, 69
004830	51
004995	50, 55, 69, 71
005...	
005000	38, 70
005050	38, 70
005055	38
005090	38
005200	39, 69, 71
005229	39, 69-71
005230	39, 69, 71
005232	55, 69
005236	69, 70
005250	39, 69, 71
005279	41, 69, 71
005291	57, 69, 221
005292	57, 69, 221
005300	48, 70
005310	49
005312	49, 69, 71
005320	48
005330	51, 69
005331	69
005333	44, 69
005335	44, 69
005337	44, 69
005600	61
005610	61
005665	43
005668	43, 69
005700	44, 69, 72
005715	51, 69, 72
005720	51, 69, 72
005921	47, 69, 177
005990	50, 55, 69, 71
006...	
006000	38, 70
006050	38, 70
006090	38
006200	39, 69, 71
006229	39, 69-71
006230	39, 69, 71
006232	55, 69
006250	39, 69, 71
006279	41, 69, 71
006291	57, 69, 221
006292	57, 69, 221
006293	57, 69, 221
006300	48, 70
006310	49
006312	49, 69, 71
006320	48
006330	51, 69
006332	44, 69

Part Number Index

Part No.	Page
006600	61
006610	61
006660	52, 69
006665	43
006680	56, 69
006682	45, 69, 172
006683	52, 69
006690	52, 69, 70
006700	44, 69, 72
006720	51, 69, 72
006995	50, 55, 69, 71
007...	
007000	38, 70
007050	38, 70
007090	38
007200	39, 68
007229	39, 68, 70-71
007230	39, 68
007232	55, 68
007250	39, 68, 71
007279	41, 68, 71
007300	48, 71
007310	49
007312	49, 68, 71
007320	48
007600	61
007610	61
007630	68
007660	50, 68, 70
007700	44, 68, 72
007720	51, 68, 72
007995	50, 55, 68, 71
008...	
008020	40, 54, 68, 71
008025	40, 53-55, 68, 71
008100	40, 54, 68, 71
008102	40, 54, 68
008105	49
008110	41, 68, 71
008120	51, 68
008130	44, 68, 72
008135	44, 68, 72
008160	41, 68
008170	62
008171	62
008183	52, 68
008185	50, 55, 68, 71
008195	68
008199	68
008420	40, 54, 68, 71
008425	40, 53-55, 68, 71
008500	40, 54, 68, 71
008502	40, 54, 68
008505	49, 69
008510	41, 69, 71
008560	41, 69
008620	51, 69, 72
008630	44, 69, 72
008635	44, 69, 72
008687	50, 55, 69, 71
008700	40, 54, 69, 71
008760	40, 54, 69, 71
008762	40, 53-55, 69
008770	41, 69
008775	62, 69
008787	55, 69
008820	51, 69, 72
008900	40, 54, 69, 71
008960	40, 54, 69, 71
008962	40, 53-55, 69, 71

Part No.	Page
008970	41, 69
008975	62, 69
008987	55, 69, 71
009...	
009462	40, 54, 69
009463	40, 53-55, 69, 71
009472	41, 69, 71
009660	40, 54, 69, 71
009670	41, 69, 71
009760	40, 54, 69, 71
009770	41, 69, 71
009910	60, 71
009920	60, 71
009930	60, 71
009980	198
009984	198
009988	198
030...	
030200	42, 60
030240	42
030260	42
030900	42
030920	42
030930	42, 60
031...	
031142	43, 69
0312170	40-41, 54, 69
0312176	40-41, 54, 69
031218	47, 68, 177
031516	40, 54, 67
031521	67
0315233	67
0315234	67
0315235	51
031535	46, 175
031536	67
031571	62
0315720	62
0315722	62
031745	64
031746	64
031747	64
031776	63
031782	31, 64
031786	63
031798	45, 68, 172
031803	44, 46, 51, 68
031805	39, 68
031807	46, 68, 170
031808	43, 68, 167
031809	43, 68, 167
031810	39, 48, 68
031811	39, 49, 59, 68
0318120	68
0318121	44, 68
031815	39, 49, 68
031816	44, 51, 68, 69
031817	44, 68
031819	52, 55, 69
0318191	55, 69
031820	39, 41, 49, 69
031821	51, 69
0318212	51
0318221	50, 55, 69
031823	43, 69
031824	47, 69, 177
031825	39, 41, 49, 69
031826	44, 51, 57, 69, 221
0318261	44, 51, 69
0318263	57, 221
0318271	50, 55, 69

Part No.	Page
031828	45, 69, 172
031830	39, 41, 49, 69
0318301	57, 69
0318303	57, 69, 221
031831	44, 51, 57, 69, 221
031832	56, 69
031833	50, 52, 55, 69
031834	52, 69
0318348	52, 69
031835	39, 41, 49, 68
031837	50, 68
031838	52
0318381	50, 55, 68
031842	40, 41, 49, 54, 61
0318441	40, 44, 50, 53-55, 68
0318444	51, 68
0318448	52, 68
0318451	44, 69
0318454	51, 69
031852	40-41, 49, 53-55, 68-69
031854	50, 55, 69
031856	40-41, 51-52, 54, 62, 69
0318562	40, 53-56, 69
031862	40-41, 54, 62, 69
031864	40, 53-56, 69
031870	40-41, 54, 69
031874	40, 53-55, 69
0318922	44, 51, 68
0318926	44, 51, 69
0318928	44, 51, 68
031902	60, 68
031903	68
031905	41
031906	41
031907	41
031910	41
031911	41
031915	41
031930	63
032...	
032002	68
032004	68
032006	68
032030	68
032527	60
032532	60
032537	60
033...	
033010	35, 65
033011	35, 65
033012	35, 65
033057	35, 65
033060	65
033605	65
033610	59, 65
033620	59, 65
033630	59, 65
033708	43, 65, 167
033715	43, 65, 167
033730	43, 65, 167, 172
033738	45, 65, 172
033745	45, 65, 172
033750	46, 65, 170
033765	46, 65, 170
033770	44, 46, 65, 175
033772	44, 46, 65, 175
034...	
034055	35, 65

Part No.	Page
034056	35, 65
034057	35, 65
034059	35, 65
034060	35, 65
034610	35, 65
034715	43, 65, 167
034720	47, 65, 177
034905	44, 46, 65
035...	
035055	35, 65
035056	35, 65
035057	35, 65
035058	35, 65
035059	35, 65
035060	35
036...	
036010	66
036011	44, 66
036030	66
036031	66
036060	66
036110	36, 37, 66
036130	37, 66
036160	66
036250	49, 66
036310	66
036410	66
036510	66
036530	66
036603	66
036605	66
036610	59, 66
036625	66
036635	59, 66
036651	59, 66
036675	59, 66
036685	59, 66
036701	59, 66
036703	59, 66
036710	43, 66, 167
036720	43, 66, 167
036730	43, 66, 167
036910	24
036912	24
036914	24
036916	24
036918	24
036920	24
037...	
037010	44-47, 66
037011	66
037013	44, 66
037021	45, 51, 66
037030	66
037031	66
037060	66
037110	36-37, 39, 66
037130	36-37, 66
037160	66
037221	66
037250	48-49, 66
037270	66
037310	66
037330	66
037410	66
037510	66
037540	66
037605	66
037610	59, 66
037675	39, 59, 66
037715	43, 66, 167
037717	43, 66, 167

Part No.	Page
037725	167
037730	43, 66, 167
037745	45, 66, 172
037747	45, 66, 172
037777	47, 66, 177
037778	66, 177
037779	66, 177
037780	66, 177
037785	66, 175, 177
037787	44, 46, 66, 175
038...	
038030	67
038060	67
038110	24, 38-39, 44, 61, 67
038111	67
038130	38, 67
038131	67
038138	67
038160	67
038161	67
038250	48-49, 51, 67
038255	67
038259	67
038260	67
038265	52
038270	67
038310	67
038410	67
038420	44
038430	67
038460	67
038510	67
038530	67
038717	43, 67
038732	44, 67
038735	67
038736	44
038737	45, 51, 67
038745	47, 67, 177
038749	44
038810	41
038815	41
038820	41
038910	67
039...	
039110	24, 40, 54, 67
039115	67
039116	67
039120	67
039125	45, 51, 67
039130	67
039138	67
039160	67
039180	51
039182	51
039250	49, 67
039256	67
039260	67
039525	45, 51
039556	51
039802	62, 67
039803	67
039807	67
039808	67
039811	67
039822	67
039823	67
039827	67
039831	67
039842	67
039847	67

Part No.	Page
039851	67
039862	67
039867	67
039871	67
039880	67
039891	67
039895	67
039897	67
041...	
041820	168
041822	60
041824	177
0418240	168, 177
041826	167, 170, 178
041828	168
041844	177
0418440	168, 177
041846	167, 170, 178
041848	168
0418491	175
041850	168
041854	177
0418540	168, 177
041856	167, 170, 178
041871	168
041872	167, 170, 178
041879	177
041880	168, 177
041882	127, 138, 167, 170, 178
041883	167-168, 170, 178
041884	168
041886	175
041890	172
041895	172
041897	168, 177
041898	167, 170, 178
0418990	175
0418991	168
0418992	168
041900	177
041901	168, 177
041902	167, 170, 178
041903	175
041905	172
041906	168
052...	
052295	195
052296	195
0540...	
054022	83
054028	83
054029	83
054039	83
054040	83
054041	83
054042	83
054043	83
054044	83
054045	83
054046	83
054047	83
054048	83
054049	83
054050	83
054051	83
054052	83
054053	83, 137
054054	83
054056	83
054058	83
054059	83

Part No.	Page
054060	83
054061	83
054062	83
054064	83
054065	83, 137
054066	83
054067	83
054068	83
054069	83
054070	83
054071	83
054072	83
054073	83
054076	83
054077	83
054081	83
054082	83
054085	84
054086	84
054087	84, 145
054088	84
054089	84
054090	84
054092	84
054095	84
054096	84
054097	84, 133
054098	87
054099	87, 124
0541...	
054100	88
054101	88, 106, 108, 111, 118, 120, 121, 122, 124, 128, 144
0541011	88
054102	88
0541025	88
054103	87
054104	87
054105	88
054106	87
054107	87
054108	87
054110	88
054112	88
054113	88, 143
054114	88, 104
054116	88
054117	88
054118	88
054119	88
054120	88
0541205	88
054121	88
054122	88
054123	88, 134
054124	88
054125	88, 105
054126	88
0541261	88
054127	88
054128	88
054129	88
054130	88
054131	88
054132	88
054133	88
054134	88
0541344	88
0541345	88
0541347	88
0541348	88

Part No.	Page
054136	88
054138	88
054139	88
054142	88
054144	88
054145	88
054146	88
054147	88
054148	88, 117
054149	88
054152	88
054153	88
054154	88
054158	88
054159	88
054160	88
054167	86
054168	86
054169	86
054171	86
054175	86
054176	87
054177	87
054178	87
054179	87
054180	87
054182	86
054183	86
054184	87
054186	87, 116
054187	87
054188	87
054189	87
054192	87
054193	87
0541935	87
054194	87
054195	87
054196	87
054197	87, 132, 145
054198	87, 144
054199	87
0542...	
054202	86
054203	86
054204	87
054215	87
054216	87
0542170	88
054229	88
054252	96
054253	96
054254	96
054255	96
054256	96
054257	96
054258	96
054259	96
054260	96
054262	96
054264	96
054265	96
054266	96
054268	96
054269	96
054270	96
054271	96
054280	96
054282	96
054283	96
0543...	
054352	97

Part Number Index

Part No.	Page
054353	97
054358	97
054364	97
0544...	
054405	95
054415	95
054420	95
054421	95
054422	95
054424	95
054425	95
054426	95
054427	95, 130-131
054428	95
054430	95
054431	95
054432	95
054433	95
054434	95
054436	95, 118
054437	95
054438	95
054439	95
054440	95
054442	95, 117, 142
054443	95
054444	95
054445	95
054447	95, 113
054448	95
054450	95
054451	95
0544515	95
054455	91-92
054456	95
054457	95
054458	95
054462	99, 109
054463	96
054464	96
054465	96
054466	96
054467	96
054468	96
054469	96
054470	96
054471	96
054472	96
054473	96, 138
054474	96
054476	96
054477	96, 131
054478	96
054480	96
054488	136
0545...	
054570	93, 113
054573	93
054580	93
054583	93
054590	93
054593	93
054596	93
0546...	
054600	93
054601	93
054602	93
054603	93
054605	93
054606	93, 114
054607	93
054610	93

Part No.	Page
054612	93
054613	93
054616	93
054617	93
054619	93
054620	93
054621	93
054622	93, 116
054623	93
054624	93
054631	89
054632	89
054633	89
054634	89
054635	89, 126
054636	89
054641	89
054642	89
054651	89
054652	89
054653	89
054655	89
054657	89
054658	89, 114, 129
054661	89, 114, 129
054662	89
054665	89
054667	89
054668	89
054670	89
054671	89
054672	89
054673	89, 127
054674	90
054675	90
054676	90
054677	90, 100
054679	90
054680	90
054681	90
054682	90
054683	90
054684	90
054685	90
054690	90
054699	91
0547...	
054700	91
054701	91, 101, 105, 132-133, 135
054702	91
0547025	91
054703	91
054704	91
054705	91
0547100	94
054711	91, 108, 141, 146
054712	91
054713	91
054714	91
0547158	91
054716	91
054717	91
054718	91
054721	91
054722	91
054723	91
054724	91
054734	91
054735	91
054736	91
054737	91

Part No.	Page
054738	92
054739	92
054740	92, 107
054741	92
054750	92
054751	92, 99, 107, 109-110, 142
054752	92
054760	92
054761	92
054762	92
054770	92
054771	92
054772	92
054777	85
054779	85
054782	85
054785	94
054786	94
054787	94
054788	94
054789	94
054791	94
054792	94
054793	86
054794	86
054795	86, 127
054796	94, 110, 115, 119, 123, 136
054797	94, 138
054798	86
0548...	
054800	85, 128-129
054801	85
054802	85, 126
0548025	85
054803	85
054806	84
054807	84
054808	84
054809	84
054810	84
054811	83
054812	83
054813	83
054815	83
054818	84
054819	84
054820	83
054823	91
054826	98, 101
054827	98
054830	98
054831	98
054832	98, 137
054834	98
054835	98, 102
054836	98
054838	98
054839	98
054840	98
054841	98
054842	98
054870	84
054871	84
0549...	
054900	98
054901	98, 115, 121
054902	98
054950	84, 125
054961	95
054963	95
054978	97

Part No.	Page
054979	97, 103
054980	97
054981	97
054982	97
054983	97
054984	97
054985	97
06240...	
062401	238
062406	238
06241...	
062415	238
062416	238
0624160	238
0624173	238
062418	238
06242...	
0624201	235
0624202	235
0624203	235
0624204	235
0624205	235
0624214	235
0624215	235
0624216	235
0624217	235
0624218	235
0624225	235
0624226	235
0624227	235
0624228	235
0624229	235
0624230	235
0624231	235
0624232	235
0624233	235
0624234	235
0624241	235
0624242	235
0624243	235
0624245	235
0624249	235
0624250	235
0624251	235
0624252	235
0624253	235
0624254	235
0624261	235
0624262	235
0624263	235
0624264	235
0624265	235
0624269	235
0624271	235
0624272	235
0624273	235
0624275	235
0624279	235
0624280	235
0624290	235
0624291	235
0624292	235
0624293	235
0624294	235
06243...	
0624300	235
0624301	235
0624302	235
0624303	235
0624304	235
0624311	235
0624312	235

Part No.	Page
0624313	235
0624315	235
0624319	235
0624341	235
0624342	235
0624343	235
0624345	235
0624349	235
0624350	235
0624351	225, 235
0624352	235
0624353	235
0624354	235
0624365	235
0624366	235
0624367	235
0624368	235
0624369	235
0624370	235
0624371	235
0624372	235
0624373	235
0624374	235
0624375	235
0624376	235
0624377	235
0624378	235
0624379	235
0624380	235
06244...	
062442	232
0624431	233
0624432	233
0624434	233
062444	232
062445	232
0624450	232
06244501	232
06244502	232
06244503	232
0624455	232
0624459	232
062446	232
0624460	232
0624461	232
0624463	232
0624465	232
0624469	233
062447	233
0624470	233
0624471	233
0624473	233
0624474	233
0624475	232
0624476	233
0624478	233
0624479	233
062448	233
062449	232
0624491	232
06245...	
062454	231
062456	231
062457	231
062458	231
06246...	
062460	231
062461	231
0624625	231
062463	231
0624635	231
0624655	231

Part No.	Page
062466	231
0624685	231
062469	231
06247...	
062470	231
062472	231
062473	231
062474	231
062475	231
062476	231
062478	231
062479	231
06248...	
062481	231
062482	231
06249...	
062492	231
0625...	
0625010	195
0625011	195
0625026	193
062503	195
0625031	195
062505	195
062506	195
0627...	
062710	231
062711	231
062712	231
062713	231
0628...	
062801	233
062803	233
062812	233
062813	233
062823	233
062881	233
064...	
064033	233
064034	233
064050	233
064051	233
064052	233
064054	233
064061	233
064062	233
064102	233
064103	233
064108	233
064114	233
065...	
0650010	223
0650020	223
072...	
0726001	173-174
0726004	176
0726005	169
0726006	169
0726007	173
072601	163, 179
072602	163, 179
072603	163-164, 191
0726080	174
0726082	174
072614	176
072617	161
072619	176
072621	161, 171, 176, 179
0726217	179
072622	160, 171, 176, 179
072624	171

Part No.	Page
072626	160, 163, 171, 179,
072627	160, 169, 171, 179
0726280	171
072635	169
072636	169
072650	191, 193, 195
0726532	169, 179
0726533	173
0726536	171
072654	160, 163, 169, 171, 174, 179,
0726548	176
0726549	176
072655	160, 163, 169, 171, 174, 179, 186
0726557	176
0726561	174
0726562	174
0726563	174
0726564	174
072657	160, 191, 193
072662	160, 186-187
072663	160, 163, 169, 171, 174, 179
072664	160, 186-187
072667	161, 169, 171, 176, 179
072669	160, 169, 171, 176, 179
0726702	160, 171
0726703	160, 171
072671	160, 171
072673	161
072696	164, 176
072697	164, 176
072698	164, 176
073...	
0730004	223, 225
0730010	223
0730014	223, 225
0730018	42
0730019	42
073109	160, 169
073111	160, 169
073113	160, 169
073200	169, 171, 174
073201	169, 171, 174
073202	169, 171, 174
073204	174
073205	174
073206	174
073219	164, 169, 172, 180
073220	169, 172, 174, 180
073221	169, 172, 174, 180
073222	169, 172, 174, 180
073224	174
073225	165
073226	165, 169
073227	174
073228	174
073229	174
073230	165, 176
073231	165, 180
073232	165, 174
073233	165, 174
073270	169
073271	169
073272	169
073273	169

Part No.	Page
073300	179
073301	179
073302	179
073303	179
073330	176
073331	176
073332	176
073333	176
073350	174
073351	174
073352	174
073400	169
073401	169
073450	176
073451	176
073452	176
073453	176
073473	227
073550	164
073551	164
073552	164
073553	164, 165
073554	164
073610	170
0736100	170
0736101	170
0736102	170
0736103	170
0736104	170
0736105	170
0736106	170
073611	170
073612	170
073614	176
073615	176
073616	176
073618	180
073619	180
073620	174
073621	174
073622	172
073623	172
073630	170, 172, 174, 176, 180
073631	170, 172, 174, 176, 180
073633	170, 172, 174, 176, 180
073636	170, 172, 174, 176, 180
073640	170
08...	
082707	237
082708	237
082709	237
082710	237
082712	237
082717	237
082718	237
082719	237
082720	237
082722	237
082723	237
082724	237
082725	237
082732	237
082733	237
082734	237
082735	237
0827352	237
0827353	237
0827354	237
0827355	237

Part No.	Page
082737	237
0827375	237
0827376	237
0827377	237
082738	237
082739	237
082740	237
082742	237
082743	237
082744	237
082745	237
082747	237
082750	237
082760	237
082767	237
082768	237
082769	237
082770	237
08277028	237
082780	238
082781	238
082782	238
090...	
090111	195
090112	195
090113	195
0920...	
092001	168, 178
09200101	168, 178
092002	114, 168, 178
09200201	168, 178
092003	107, 124, 128, 168, 178
09200301	168
092004	168, 169
09200401	168, 169
092005	107, 124, 168, 178
09200501	168, 178
092007	168, 178
09200701	168, 178
092008	168, 178
092010	168, 178
09201001	168, 178
092011	168, 178
092013	168, 178
09201301	168, 178
092016	168, 178
09201601	168, 178
092017	103, 109, 111, 115, 119, 123, 133-136, 138, 142, 168, 178
09201701	168, 178
092018	99, 105-106, 110, 118-122, 127, 132, 137, 144, 168, 178
09201801	168, 178
092019	178
09201901	178
092021	178
09202101	178
092022	179
09202201	179
092024	179
09202401	179
092025	178
09202501	178
092026	178
09202601	178
092027	179
09202701	179
092028	178

Part No.	Page
09202801	178
092030	179
09203001	179
092031	179
09203101	179
092034	179
09203401	179
09203425	179
092036	179
09203601	179
09203625	179
092037	179
09203701	179
09203725	179
092038	179
09203801	179
09203825	179
092039	175
09203901	175
092045	175
09204501	175
092046	175
09204601	175
09204625	175
092048	175
09204801	175
092049	173
09204901	173
092058	173
09205801	173
09205825	173
092059	173
09205901	173
09205925	173
092061	173
09206101	173
092062	173
09206201	173
09206225	173
092064	173
09206401	173
092065	173
09206501	173
092066	173
09206601	173
092068	173
09206801	173
09206825	173
092071	173
09207101	173
092077	173
09207701	173
09207725	173
092082	173
09208201	173
0920831	173
092083101	173
092084	173
09208401	173
092085	173
09208501	173
09208525	173
0920861	171, 173
092086101	171, 173
092087	173
09208701	173
092089	171, 173
09208901	171, 173
092091	171
09209101	171
092092	171
09209201	171

Part No.	Page
09209225	171
092094	171
09209401	171
092095	171
09209501	171
09209525	171
092097	171
09209701	171
092098	171
09209801	171
0920990	171
09209901	171
092099025	171
0921...	
092100	171
09210001	171
09210025	171
092101	171
09210101	171
092103	168, 171, 178
09210301	168, 171, 178
092111	168, 178
09211101	168, 178
092113	178
09211301	178
092115	168, 178
092117	179
09211701	179
092141	175
09214101	175
09214125	175
092142	175
09214201	175
09214225	175
092144	175
09214401	175
09214425	175
092147	175
09214701	175
09214725	175
092148	175
09214801	175
092150	175
0921501	175
09215025	175
092154225	175
092155	175
09215501	175
09215525	175
0922...	
092210	169
09221001	169
092211	169
092218	168
092219	168, 178
09221901	178
092220	168, 178
09222125	178
092222	168, 178
092223	168, 178
092224	168, 178
092228	179
092229	168, 178
092230	168, 178
092234	168
09223401	168
092235	168
092236	171
09223601	171
092243	169
09224301	169
092244	171

Part No.	Page
09224401	171
092245	179
09224501	179
09224525	179
092246	169
0922601	169
092270	180
0922701	180
092272	180
09227201	180
092273	180
09227301	180
0923...	
092324	168
09232401	168
092325	168
09232501	168
092326	168
09232601	168
092329	173
09232901	173
092330	173
09233001	173
092331	173
09233101	173
092334	176
09233401	176
092335	176
09233501	176
092336	176
09233601	176
092339	179
09233901	179
092340	179
09234001	179
092341	179
09234101	179
092344	171
09234401	171
092345	171
09234501	171
092346	171
09234601	171
093...	
0933424	193
093346	193
10...	
101230	163
101250	163
101270	163
101290	163
101300	163
101310	163
101320	163
101340	163
1021003	223
1021011	223
103330	163
1033301	163
103400	163-164
103401	163-164
103402	163-164
103403	163-164, 193
1034030	163-164
103404	193
103405	163-164, 193
103406	164
1034060	179
103408	163-164, 193
1034085	176

Part No.	Page
103418	163
1034180	163
1034181	163
1034183	163
1034187	164
103419	163
103420	163
1034200	163
103427	163
103428	163
103430	164
103431	164
103432	164
103433	164
1034606	191
103469	194
103470	194
103474	194
103475	194
103477	194
103479	194
103480	165
103481	166
103482	166
103486	166
103487	165
103488	166
103491	166
103494	165
103495	166
12...	
1236012	190
1236020	190
1236032	190
1236071	189
1236091	189
1236101	191
1236103	189
1236104	189
1236281	189, 191
1236282	191
1236283	190
1236291	187
123630	187
1236300	163
1236302	163
1236306	163
123632	186
123633	186
123634	186, 187
123681	191
123683	191
123687	191
123703	185
123708	227
123720	185
123721	185
123722	185
123730	185
123731	185
123732	185
123740	227
123741	227
14...	
14133	243
14133H	243
14143	243-244
14144	243-244
14147	180, 242, 244
14150HM9	243-244
14210	243, 244
14214	243, 244

Part No.	Page
14217	242, 244
14222	242-243
14511	170, 242-243
14516	170, 242-243
14533	174, 242, 244
14562A	242, 244
14566	242, 244
14573	242-243
14610	242-243
14616	170, 242-243
14617	170, 242-243
14630	242, 244
14632	242, 244
14820	243-244
14823H	243-244
14824	243-244
14834H	242-244
14870	243-244
14874	243-244
14875	243
18...	
18060001	198
18614600	187
1861461	187
18614610	187
18614620	187
1862460	187
20...	
200005	224
200009	225
200010	53
202002	224
2020035	224
202009	222
2020155	224
202016	224
204000	227
204002	222
205000	226
205001	226
2050010	226
2050014	226
205002	226
205003	226
205004	226
205005	226
205006	226
205007	226
205008	226
206102	223
206160	223
2062746	225
2062747	225
2062752	225
2062753	225
21...	
212005	222
212006	224
212007	224
212008	224
212009	225
212010	225
212011	225
212012	222
213006	225
213007	225
213008	225
22...	
222002	222, 225
222005	224
222006	224
222007	224

Part No.	Page
222008	222
222009	225
222010	225
222011	225
222012	222
222016	222
222017	222, 225
222204	206
222205	206
2222054	205
2222066	205
2222070	205
2222072	205
2222158	205
222404	206
2224054	205
2224058	205
2224072	205
2227054	205
223005	225
223006	225
223007	225
25...	
250003	206
250005	206
250007	206
250009	206
250013	206
250015	206
250017	206
250019	206
250021	206
250023	206
250025	206
250027	206
250029	206
250031	206
250033	206
250100	204, 213
250102	204, 208, 215
250105	204
250107	204
250110	204, 207
250112	204, 207
250115	204
250117	204
250120	204
250122	204
250125	204
250127	204
250130	204
250132	204
250135	205
250137	205, 211-212
250140	205, 209
250142	205
250150	204
250152	204
250155	205
250157	205
250160	205
250162	205
250170	204, 210
250172	204
250175	205
250177	205
250180	205
250182	205
250190	204
250192	204
250195	204
250197	204

Part No.	Page
250200	204
250202	204
250210	204
250212	204, 207
250215	204
250217	204
290...	
2900101	221
2900102	221
2900103	221
2900104	221
2900105	221
2900106	221
2900301	221
2900302	221
2900303	221
2900304	221
2900305	221
2900306	221
2900401	221
2900402	221
2900403	221
2900404	221
2900405	221
2900406	221
2900408	221
2900409	221
2900501	221
2900502	221
2900503	221
2900504	221
2900505	221
2900506	221
2900508	221
2900509	221
2900601	221
2900602	221
2900603	221
2900604	221
2900605	221
2900606	221
2900701	221
2900702	221
2900703	221
2900705	221
2900706	221
2900707	221
2900711	221
2900712	221
2900713	221
2900715	221
2900716	221
2900717	221
291...	
2910000	24
2910005	24
2910010	24
2910012	24
2910020	24, 69
2910021	24, 69
2910022	24, 69
2910023	24, 69
2910024	24, 69
2910025	24, 69
2910026	24, 57, 69
2910027	24, 57, 69
2910028	24, 57
2910029	24
2910030	24
2910040	24
2910100	24
2910320	24

Part No.	Page
2910322	24
2910324	24
2910329	24
2910380	24, 69
2910382	24, 57, 69
2910383	24, 57
2910384	45, 57, 69
292...	
2926210	45
2926230	51
2928310	45, 69
2928330	51, 69
2928410	45, 69
2928430	51, 69
2928500	57, 221
2928510	45, 69
2928530	51, 69
2928600	57, 221
2928610	45, 69
2928630	51, 69
2928710	45, 69
2928730	51, 69
2928820	45, 69
2928830	51, 69
2928920	45, 69
2928922	45, 69
2928930	51, 69
2928932	51, 69
293...	
2930380	45, 51, 69
2930480	45, 51, 69
2930580	45, 51, 57, 69
2930680	45, 51, 57, 69
2930780	45, 51, 69
2930880	45, 51, 69
2930980	45, 51, 69
2930985	45, 51, 69

GC Applications	Page
A	
ACI 02 Analysis of Organic Acids in Water on BP21	131
ACI 03 Analysis of 11 Organic Acids on BP20	131
Acid/Neutral Drugs on BPX35, PHA 01	146
Acrylic Acid/Acrylamide Analysis on BP21, SOL 04	138
ALC 02 Analysis of 18 Alcohols on BP20	130
ALC 06 US EPA 625 Phenols Mix on BPX50	109
ALC 09 Analysis of a Phenols Mixture on BPX35	135
Alcohols on BP20, ALC 02	130
Alkaloids on BP5, PHA 03	144
AMI 03 Analysis of Aromatic Amines on BP5	132
AMI 04 Analysis of Amines on BP1	133
AMI 06 Analysis of Aromatic Amines from Diazo Dyes on BPX35	132
Amines on BP1, AMI 04	133
AN-0011-C Analysis of Omega-3 Fatty Acids using a Highly Selective GC Capillary Column	114
AN-0022-C FAME Analysis with BPX90 – A Highly Polar Column	113
Antidepressant and Anticonvulsant Drugs on BPX50, PHA 19	142
AP 0040C HT8: The Perfect PCB Column	100
ARO 08 Analysis of Polynuclear Aromatic Hydrocarbons on HT8	99
ARO 13 Analysis of BTEX on SolGel-WAX™	110
ARO 14 Analysis of chlorinated and nitroaromatic compounds on SolGel-1ms™	109
Aromatic Amines from Diazo Dyes on BPX35, AMI 06	132
Aromatic Amines on BP5, AMI 03	132
B	
Barbiturates (Underivatized) on BP5, PHA 10	145
Blood Alcohol on BP20, PHA 13	142
BP1, AMI 04 Analysis of Amines	133
BP1, PHA 04 Analysis of Sedatives/Hypnotics	145
BP1, POL 05 Pyrolysis of Styrene-isoprene Copolymer Pyrolysis of Polystyrene	137
BP1, TP-0138-C Analysis Of Polybrominated Diphenyl Ethers	139
BP1-PONA, PET 01 Analysis of Gasoline Range Hydrocarbons	125
BP20, ACI 03 Analysis of 11 Organic Acids	131
BP20, ALC 02 Analysis of 18 Alcohols	130
BP20, FLA 03 Analysis of Orris Concentrate	118
BP20, FOO 03 Analysis of Scotch Whisky	113
BP20, FOO 24 Analysis of Wine	117
BP20, PHA 13 Analysis of Blood Alcohol	142
BP20, POL 01 Analysis of Unreacted Monomers in Latex	136
BP21, ACI 02 Analysis of Organic Acids in Water	131
BP21, SOL 04 Acrylic Acid/Acrylamide Analysis	138
BP5, AMI 03 Analysis of Aromatic Amines	132
BP5, FOO 02 Analysis of Food Additives Antimicrobials	116
BP5, PHA 03 Analysis of Alkaloids	144
BP5, PHA 10 Underivatized Barbiturates	145
BP624, ENV 13 Analysis of Volatiles from Drinking Water	102
BP624, ENV 17 Analysis of 16 Volatile Compounds in Drinking Water	101
BP624, SOL 21 Analysis of a Common Solvent Mixture	137
BPX1, PET 18 Analysis of Polywax 655 on Megabore	128
BPX1, PET 26 Standard for D2887	126
BPX1-SimD a New Era in Simulated Distillation Technology, ENV 54	129
BPX35, ALC 09 Analysis of Phenols Mixture	135
BPX35, AMI 06 Analysis of Aromatic Amines from Diazo Dyes	132
BPX35, ENV 04 Analysis of Herbicides	108
BPX35, ENV 57 8081 Organochlorine Pesticide Mix	105
BPX35, PHA 01 Analysis of Acid/Neutral Drugs	146
BPX35, PHA 09 Analysis of Tricyclic Antidepressants	141
BPX35, PHA 14 Analysis of Drugs of Abuse	141
BPX35, SOL 25 Analysis of 22 Ketones	133

GC Applications	Page
BPX5 (10-20 ng/component), PHA 06 Analysis of Basic Drug Screen	143
BPX5 Column, FOO 21 Plant Sterols	117
BPX5, ENV 03 Analysis of 18 Chlorinated Pesticides	105
BPX5, ENV 20 Analysis of Polychlorinated p-Dibenzodioxins	104
BPX5, ENV 48 Analysis of Herbicides	108
BPX5, ENV 54 Total Recoverable Petroleum Hydrocarbons (TRPH) Analysis on Standard and Fast	124
BPX5, ENV 59 8141 Organophosphorous Pesticide Mix	106
BPX5, ENV 84 Analysis of US EPA 8270 Mix	111-112
BPX5, FLA 12 Analysis of Nutmeg Oil	121
BPX5, FLA 13 Analysis of Rosemary Oil	122
BPX5, FLA 14 Analysis of Lavender Oil	118
BPX5, FLA 15 Analysis of Tea Tree Oil	120
BPX5, FLA 16 Analysis of Pine Oil	120
BPX5, PET 22 Unleaded Gasoline	128
BPX5, PHA 08 Underivatized Steroid Analysis	143
BPX5, PHA 15 Analysis of Horse Racing Test Mix	144
BPX5, SOL 33 Analysis of Ketones on Thick Film	134
BPX5, TP-0138-C Analysis Of Polybrominated Diphenyl Ethers	139
BPX50, ALC 06 US EPA 625 Phenols Mix	109
BPX50, ENV 62 Polynuclear Aromatic Hydrocarbons (PAH)	99
BPX50, ENV 65 Analysis of Synthetic Pyrethroids	110
BPX50, PHA 19 Analysis of a Variety of Antidepressant and Anticonvulsant Drugs	142
BPX50, TP-0187-C Analysis of Polynuclear Aromatic Hydrocarbons	101
BPX70, FOO 04 Analysis Of 13 Sugar Component Alditol Acetate Mixture	116
BPX70, TP-0138-C Analysis Of A Mixture Of PBDD, PCDD And PBDF	140
BPX90 – A Highly Polar Column, AN-0022-C FAME Analysis	113
BTEX ON SolGel-WAX™, ARO 13	110
C	
Chlorinated and nitroaromatic compounds on SolGel-1ms™, ARO 14	109
Chlorinated Pesticides on BPX5, ENV 03	105
Crude Oil and Wax Mixtures on HT5, PET 11	126
CYDEX-B, FLA 05 Analysis of Menthol Oil	115
D	
Drinking Water on BP624 ENV13	102
Distillation Technology (SIM-D), ENV 54 BPX1	129
Drug Screen on BPX5 (10-20 ng/component), PHA 06	143
Drugs of Abuse on BPX35, PHA 14	141
E	
ENV 03 Analysis of 18 Chlorinated Pesticides on BPX5	105
ENV 04 Analysis of Herbicides on BPX35	108
ENV 13 Analysis of Volatiles from Drinking Water on BP624	102
ENV 17 Analysis of 16 Volatile Compounds in Drinking Water on BP624	101
ENV 20 Analysis of Polychlorinated p-Dibenzodioxins on BPX5	104
ENV 45 Organophosphorous Pesticides on BPX50	107
ENV 48 Analysis of Herbicides on BPX5	108
ENV 51 Total Recoverable Petroleum Hydrocarbons (TRPH) C8-C40 on SolGel-1ms™	127
ENV 52 Industrial Solvents on SolGel-WAX™	138
ENV 54 BPX1-SimD a New Era in Simulated Distillation Technology	129
ENV 54 Total Recoverable Petroleum Hydrocarbons (TRPH) Analysis on Standard and Fast BPX5	124
ENV 57 8081 Organochlorine Pesticide Mix on BPX35	105
ENV 59 8141 Organophosphorous Pesticide Mix on BPX5	106
ENV 62 Polynuclear Aromatic Hydrocarbons (PAH) Analysis on BPX50	99
ENV 65 Analysis of Synthetic Pyrethroids on BPX50	110
ENV 84 Analysis of US EPA 8270 Mix on BPX5	111-112

GC Applications	Page
Environmental GC Application by Industry	99-112
Eucalyptus Oil on SolGel-WAX™, FLA 19	115
F	
FAME Analysis with BPX90 – A Highly Polar Column AN-0022-C	113
FLA 03 Analysis of Orris Concentrate on BP20	118
FLA 05 Analysis of Menthol Oil on CYDEX-B	115
FLA 05 Analysis of Menthol Oil on CYDEX-B	121
FLA 12 Analysis of Nutmeg Oil on BPX5	121
FLA 13 Analysis of Rosemary Oil on BPX5	122
FLA 14 Analysis of Lavender Oil on BPX5	118
FLA 15 Analysis of Tea Tree Oil on BPX5	120
FLA 16 Analysis of Pine Oil on BPX5	120
FLA 18 Analysis of Ylang Ylang Oil on SolGel-WAX™	119
FLA 19 Analysis of Eucalyptus Oil on SolGel-WAX™	115
FLA 21 Analysis of Spearmint Oil on SolGel-WAX™	119
FLA 22 Analysis of Tasmanian Lavender Oil on SolGel-WAX™	123
FOO 02 Analysis of Food Additives Antimicrobials on BP5	116
FOO 03 Analysis of Scotch Whisky on BP20	113
FOO 04 Analysis Of 13 Sugar Component Alditol Acetate Mixture on BPX70	116
FOO 16 Analysis of Triglyceride Standards on HT5	114
FOO 21 Plant Sterols on a 0.53 mm ID BPX5 Column	117
FOO 24 Analysis of Wine on BP20	117
Food Additives Antimicrobials on BP5, FOO 02	116
Food, Flavor, Fragrance GC Application by Industry	113-123
Forensic GC Application by Industry	141-146
Fuels & Petrochemicals GC Application by Industry	124-129
G	
Gasoline Range Hydrocarbons on BP1-PONA, PET 01	125
GC Application by Industry	99-146
GC Application by Industry Environmental	99-112
GC Application by Industry Food, Flavor, Fragrance	113-123
GC Application by Industry Forensic	141-146
GC Application by Industry Fuels & Petrochemicals	124-129
GC Application by Industry General Chemistry	130-140
General Chemistry GC Application by Industry	130-140
H	
Herbicides on BPX35, ENV 04	108
Herbicides on BPX5, ENV 48	108
Highly Selective GC Capillary Column, AN-0011-C Analysis of Omega-3 Fatty Acids	114
Horse Racing Test Mix on BPX5, PHA 15	144
HT5, FOO 16 Analysis of Triglyceride Standards on	114
HT5, PET 06 Analysis of Polywax 655 and Refinery Lubrication Oil	129
HT5, PET 11 Analysis of Crude Oil and Wax Mixtures	126
HT5, PET 27 Analysis of Polywax 1000 on an Aluminum Clad HT5	127
HT8, ARO 08 Analysis of Polynuclear Aromatic Hydrocarbons	99
HT8: The Perfect PCB Column AP 0040C	100
HT8-PCB, TP-0138-C Analysis Of A Mixture Of Pentachlorobiphenyls	140
I	
Industrial Solvents on SolGel-WAX™, ENV 52	138
K	
Ketones on BPX35, SOL 25	133
Ketones on Thick Film BPX5, SOL 33	134
L	
Lavender Oil on BPX5, FLA 14	118
Lavender Oil (Tasmanian) on SolGel-WAX™, FLA 22	123
M	
Menthol Oil on CYDEX-B, FLA 05	115
Mixture Of PBDD, PCDD and PBDF on BPX70, TP-0138-C	140
Monomers on SolGel-WAX™, POL 06	136

GC Applications	Page
N	
Nutmeg Oil on BPX5, FLA 12	121
O	
Omega-3 Fatty Acids using a Highly Selective GC Capillary Column, AN-0011-C	114
Organic Acids in Water on BP21, ACI 02	131
Organic Acids on BP20, ACI 03	131
Organochlorine Pesticide Mix on BPX35, ENV 57 8081	105
Organophosphorous Pesticide Mix on BPX5, ENV 59 8141	106
Organophosphorous Pesticides on BPX50 ENV 45	107
Orris Concentrate on BP20, FLA 03	118
P	
PCB Column, AP 0040C HT8: The Perfect	100
Pentachlorobiphenyls on HT8-PCB, TP-0138-C	140
PET 01 Analysis of Gasoline Range Hydrocarbons on BP1-PONA	125
PET 06 Analysis of Polywax 655 and Refinery Lubrication Oil on HT5	129
PET 11 Analysis of Crude Oil and Wax Mixtures on HT5	126
PET 18 Analysis of Polywax 655 on Megabore BPX1	128
PET 22 Unleaded Gasoline on BPX5	128
PET 26 Standard for D2887 on BPX1	126
PET 27 Analysis of Polywax 1000 on an Aluminum Clad HT5	127
Petroleum Hydrocarbons (TRPH) Analysis on Standard and Fast BPX5, ENV 54 Total Recoverable	124
Petroleum Hydrocarbons (TRPH) C8-C40 on SolGel-1ms™, ENV 51 Total Recoverable	127
PHA 01 Analysis of Acid/Neutral Drugs on BPX35	146
PHA 03 Analysis of Alkaloids on BP5	144
PHA 04 Analysis of Sedatives/Hypnotics on BP1	145
PHA 06 Analysis of Basic Drug Screen on BPX5 (10-20 ng/component)	143
PHA 08 Underivatized Steroid Analysis on BPX5	143
PHA 09 Analysis of Tricyclic Antidepressants on BPX35	141
PHA 10 Underivatized Barbiturates on BP5	145
PHA 13 Analysis of Blood Alcohol on BP20	142
PHA 14 Analysis of Drugs of Abuse on BPX35	141
PHA 15 Analysis of Horse Racing Test Mix on BPX5	144
PHA 19 Analysis of a Variety of Antidepressant and Anticonvulsant Drugs on BPX50	142
Phenols Mixture on BPX35, ALC 09	135
Pine Oil on BPX5, FLA 16	120
Plant Sterols on a 0.53 mm ID BPX5 Column, FOO 21	117
POL 01 Analysis of Unreacted Monomers in Latex on BP20	136
POL 05 Pyrolysis of Styrene-isoprene Copolymer Pyrolysis of Polystyrene on BP1	137
POL 06 Analysis of Various Monomers on SolGel-WAX™	136
Polybrominated Diphenyl Ethers on BP1, TP-0138-C	139
Polybrominated Diphenyl Ethers on BPX5, TP-0138-C	139
Polychlorinated p-Dibenzodioxins on BPX5, ENV 20	104
Polynuclear Aromatic Hydrocarbons (PAH) Analysis on BPX50 ENV 62	99
Polynuclear Aromatic Hydrocarbons on BPX50, TP-0187-C	101
Polynuclear Aromatic Hydrocarbons on HT8, ARO 08	99
Polywax 1000 on an Aluminum Clad HT5, PET 27	127
Polywax 655 and Refinery Lubrication Oil on HT5, PET 06	129
Polywax 655 on Megabore BPX1, PET 18	128
R	
Rosemary Oil on BPX5, FLA 13	122
S	
Scotch Whisky on BP20, FOO 03	113
Sedatives/Hypnotics on BP1, PHA 04	145
SOL 04 Acrylic Acid/Acrylamide Analysis on BP21	138
SOL 21 Analysis of a Common Solvent Mixture on BP624	137
SOL 25 Analysis of 22 Ketones on BPX35	133
SOL 33 Analysis of Ketones on Thick Film BPX5	134

GC Applications	Page
SolGel-1ms™, ARO 14 Analysis of chlorinated and nitroaromatic compounds	109
SolGel-1ms™, ENV 51 Total Recoverable Petroleum Hydrocarbons (TRPH) C8-C40	127
SolGel-WAX™, ARO 13 Analysis of BTEX	110
SolGel-WAX™, ENV 52 Industrial Solvents	138
SolGel-WAX™, FLA 18 Analysis of Ylang Ylang Oil	119
SolGel-WAX™, FLA 19 Analysis of Eucalyptus Oil	115
SolGel-WAX™, FLA 21 Analysis of Spearmint Oil	119
SolGel-WAX™, FLA 22 Analysis of Tasmanian Lavender Oil	123
SolGel-WAX™, POL 06 Analysis of Various Monomers	136
Solvent Mixture on BP624, SOL 21	137
Spearmint Oil on SolGel-WAX™, FLA 21	119
Steroid Analysis (Underivatized) on BPX5, PHA 08	143
Styrene-isoprene Copolymer Pyrolysis of Polystyrene on BP1, POL 05	137
Sugar Component Alditol Acetate Mixture on BPX70, FOO 04	116
Synthetic Pyrethroids on BPX50, ENV 65	110
T	
Tea Tree Oil on BPX5, FLA 15	120
TP-0102-C Analysis of Volatile Organic Pollutants on a Volatiles GC Column	103
TP-0138-C Analysis Of A Mixture Of PBDD, PCDD and PBDF on BPX70	140
TP-0138-C Analysis Of A Mixture Of Pentachlorobiphenyls on HT8-PCB	140

GC Applications	Page
TP-0138-C Analysis Of Polybrominated Diphenyl Ethers on BP1 and BPX5	139
TP-0187-C Analysis of Polynuclear Aromatic Hydrocarbons on BPX50	101
Tricyclic Antidepressants on BPX35, PHA 09	141
Triglyceride Standards on HT5, FOO 16	114
U	
Unleaded Gasoline on BPX5, PET 22	128
Unreacted Monomers in Latex on BP20, POL 01	136
US EPA 625 Phenols Mix on BPX50 ALC 06	109
US EPA 8270 Mix on BPX5, ENV 84	111-112
V	
Volatile Compounds in Drinking Water on BP624, ENV 17	101
Volatile Organic Pollutants on a Volatiles GC Column, TP-0102-C	103
Volatiles from Drinking Water on BP624, ENV 13	102
Volatiles GC Column, TP-0102-C Analysis of Volatile Organic Pollutants	103
W	
Wine on BP20, FOO 24	117
Y	
Ylang Ylang Oil on SolGel-WAX™, FLA 18	119

Chromatogram Index | HPLC Applications

HPLC Applications	Page
B	
BPI/EIC Chromatograms of BSA Tryptic Peptides on ProteCol™ C18 HQ303	211
BPI/EIC Chromatograms of Human α 1-proteinase Inhibitor Tryptic Peptides on ProteCol™ C18 HQ303	212
BSA Tryptic Peptides on ProteCol™ C18 HQ303 - BPI/EIC	211
E	
Enolase Trypsin Digest on ProteCol™ Trap Column C18 HQ303	209
EPA 610 on ProteCol™ C18 GP125 - Polynuclear Aromatic Hydrocarbons (PAH) analysis	207
Extraction and Analysis of Urinary Antitussive Metabolites using MEPS™ and ESI-LCMS on ProteCol™ P C18 HQ105 - TA-0135-M	214
F	
Measuring Fruit Juice Adulteration by Changes in Flavonoid Content using MEPS™ on ProteCol™ HQ105 - TP-0199-H	208
H	
Human α 1-proteinase Inhibitor Tryptic Peptides on ProteCol™ C18 HQ303 - BPI/EIC	212
N	
NIST SRM 870 on ProteCol™ C18 HQ105 - TP-0190-H	213
P	
PAHs using EPA 610 on ProteCol™ C18 GP125	207
Paraben Mixture on ProteCol™ C18 HPH125	207
Polynuclear Aromatic Hydrocarbons (PAH) analysis on BPX 50	153

HPLC Applications	Page
ProteCol™ C18 GP125 - PAHs using EPA 610	207
ProteCol™ C18 HPH125 - Paraben Mixture	207
ProteCol™ C18 HQ105 - NIST SRM 870 - TP-0190-H	213
ProteCol™ C18 HQ303 - BPI/EIC Chromatograms of BSA Tryptic Peptides	211
ProteCol™ C18 HQ303 - BPI/EIC Chromatograms of Human α 1 - proteinase Inhibitor Tryptic Peptides	212
ProteCol™ C8 HQ 1003 - Ribosomal Proteins - TA-0414-H	210
ProteCol™ HQ105 - Measuring Fruit Juice Adulteration by Changes in Flavonoid Content using MEPS™	208
ProteCol™-P C18 HQ105 - Extraction and Analysis of Urinary Antitussive Metabolites using MEPS™ and ESI-LCMS - TA-0135-M	214
ProteCol™ Trap Column C18 HQ303 -Enolase Trypsin Digest	209
R	
Ribosomal Proteins on ProteCol™ C8 HQ 1003 - TA-0141-H	210
T	
TA-0135-M The Extraction and Analysis of Urinary Antitussive Metabolites using MEPS™ and ESI-LCMS on ProteCol™-P C18 HQ105	214
TA-0141-H Ribosomal Proteins on ProteCol™ C8 HQ 1003	210
TP-0190-H NIST SRM 870 on ProteCol™ C18 HQ105	213
TP-0199-H Measuring Fruit Juice Adulteration by Changes in Flavonoid Content using MEPS™ on ProteCol™ HQ105	208

Disclaimers

SGE Products

Our products are not suitable for medical use.

Availability

All SGE products shown are subject to availability.

Continuous Improvements

SGE is continually developing and improving our products. SGE reserves the right to change product specifications without notice.

Returns

In consideration of the health and wellbeing of our employees, SGE products contaminated by hazardous materials **MUST NOT BE RETURNED**.

Errors

The information published in this catalogue is, to the best of our knowledge, correct and accurate, but is not guaranteed to be so. SGE assumes no responsibility in this respect.

Product Warranty

SGE products are warranted to meet the stated quality and performance and to be free of defects in material or workmanship

for a period of forty five (45) days from the date of shipment. The warranty implies free replacement of a defective product only upon proper written proof of the defect and upon return of the defective product. It does not apply to mishandling of product by the customer, either in use or in storage, or to claims made after the warranty period has elapsed. No warranty or representation is expressed or implied by SGE for its products with respect to merchantability, fitness for any particular use or purpose, or any other matter. SGE shall not, under any circumstances, be liable for any incidental, consequential, or compensatory damages arising from use of or in conjunction with its products. The maximum liability for breach of warranty shall be the invoice price of the said product(s).

Trademarks

Mentioned trademarks are registered trademarks of their respective owners. No license or immunity under any patent is granted or implied by our sale of any material.

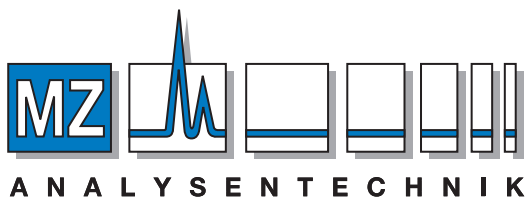

MZ-Analysentechnik GmbH
 Wöhlerstraße 2-6 • D-55120 Mainz

Tel +49 6131 68 66 19

Fax +49 6131 68 66 20

e-mail: info@mz-at.de

www.mz-at.de

AUSTRALIA & PACIFIC REGION

SGE Analytical Science Pty Ltd
 7 Argent Place, Ringwood
 Victoria 3134 Australia
 Toll Free: 1800 800 167
 Tel: +61 (0) 3 9837 4200
 Fax: +61 (0) 3 9874 5672
 Email: support@sge.com

CHINA

SGE Shanghai Representative Office
 Room 8221A, No. 808 Hongqiao Road
 Shanghai China
 Tel: +86 21 6407 9382
 Fax: +86 21 6407 9386
 Email: china@sge.com

UNITED STATES OF AMERICA

SGE Incorporated
 2007 Kramer Lane
 Austin Texas 78758 USA
 Toll Free: (800) 945 6154
 Tel: +1 512 837 7190
 Fax: +1 512 836 9159
 Email: usa@sge.com

EUROPE

SGE Europe Ltd
 European Head Office
 1 Potters Lane
 Kiln Farm Milton Keynes
 MK11 3LA United Kingdom
 Toll Free: 00800 2790 8999
 Toll Free Fax: 00800 2626 2609
 Tel: +44 1908 568 844
 Fax: +44 1908 566 790
 Tel France: +33 1 69 29 80 90
 Fax France: +33 1 69 29 09 25
 Tel Germany: +49 (0) 6155 / 60746 0
 Fax Germany: +49 (0) 6155 / 60746 50
 Email: europe@sge.com

INDIA

SGE Laboratory Accessories Pvt Ltd
 430 Milan Industrial Estate
 Abhudaya Nagar T. J. Road
 Mumbai - 400 033 India
 Tel: +91 22 24715896
 Fax: +91 22 24716592
 Email: sgeindia@vsnl.com

JAPAN

SGE Japan Inc
 RK CUBE 3F 6-85, Ohta-machi
 Naka-Ku, Yokohama-shi
 Kanagawa 231-0011 Japan
 Tel: +81 45 222 2885
 Fax: +81 45 222 2887
 Email: japan@sge.com

